

Methodology for Predicting Channel Migration

Prepared for:
National Cooperative Highway Research Program

TRANSPORTATION RESEARCH BOARD
OF THE NATIONAL ACADEMIES

Submitted by:

**P.F. Lagasse
L.W. Zevenbergen
W.J. Spitz
C.R. Thorne
Ayres Associates, Inc.
Fort Collins, Colorado**

August 2004

ACKNOWLEDGMENT

This work was sponsored by the American Association of State Highway and Transportation Officials (AASHTO), in cooperation with the Federal Highway Administration, and was conducted in the National Cooperative Highway Research Program (NCHRP), which is administered by the Transportation Research Board (TRB) of the National Academies.

DISCLAIMER

The opinion and conclusions expressed or implied in the report are those of the research agency. They are not necessarily those of the TRB, the National Research Council, AASHTO, or the U.S. Government.

This report has not been edited by TRB.

THE NATIONAL ACADEMIES

Advisers to the Nation on Science, Engineering, and Medicine

The **National Academy of Sciences** is a private, nonprofit, self-perpetuating society of distinguished scholars engaged in scientific and engineering research, dedicated to the furtherance of science and technology and to their use for the general welfare. On the authority of the charter granted to it by the Congress in 1863, the Academy has a mandate that requires it to advise the federal government on scientific and technical matters. Dr. Bruce M. Alberts is president of the National Academy of Sciences.

The **National Academy of Engineering** was established in 1964, under the charter of the National Academy of Sciences, as a parallel organization of outstanding engineers. It is autonomous in its administration and in the selection of its members, sharing with the National Academy of Sciences the responsibility for advising the federal government. The National Academy of Engineering also sponsors engineering programs aimed at meeting national needs, encourages education and research, and recognizes the superior achievements of engineers. Dr. William A. Wulf is president of the National Academy of Engineering.

The **Institute of Medicine** was established in 1970 by the National Academy of Sciences to secure the services of eminent members of appropriate professions in the examination of policy matters pertaining to the health of the public. The Institute acts under the responsibility given to the National Academy of Sciences by its congressional charter to be an adviser to the federal government and, on its own initiative, to identify issues of medical care, research, and education. Dr. Harvey V. Fineberg is president of the Institute of Medicine.

The **National Research Council** was organized by the National Academy of Sciences in 1916 to associate the broad community of science and technology with the Academy's purposes of furthering knowledge and advising the federal government. Functioning in accordance with general policies determined by the Academy, the Council has become the principal operating agency of both the National Academy of Sciences and the National Academy of Engineering in providing services to the government, the public, and the scientific and engineering communities. The Council is administered jointly by both the Academies and the Institute of Medicine. Dr. Bruce M. Alberts and Dr. William A. Wulf are chair and vice chair, respectively, of the National Research Council.

The **Transportation Research Board** is a division of the National Research Council, which serves the National Academy of Sciences and the National Academy of Engineering. The Board's mission is to promote innovation and progress in transportation through research. In an objective and interdisciplinary setting, the Board facilitates the sharing of information on transportation practice and policy by researchers and practitioners; stimulates research and offers research management services that promote technical excellence; provides expert advice on transportation policy and programs; and disseminates research results broadly and encourages their implementation. The Board's varied activities annually engage more than 5,000 engineers, scientists, and other transportation researchers and practitioners from the public and private sectors and academia, all of whom contribute their expertise in the public interest. The program is supported by state transportation departments, federal agencies including the component administrations of the U.S. Department of Transportation, and other organizations and individuals interested in the development of transportation.

www.TRB.org

www.national-academies.org

CONTENTS

ABSTRACT.....	ix
ACKNOWLEDGMENTS	x
METHODOLOGY FOR PREDICTING CHANNEL MIGRATION.....	1
SUMMARY.....	1
CHAPTER 1 Introduction and Research Approach	4
PROBLEM STATEMENT AND RESEARCH OBJECTIVES	4
SCOPE OF RESEARCH	5
RESEARCH APPROACH	6
Task 1 – Literature Review.....	8
Task 2 – Document Case Histories.....	9
Task 3 – Assemble and Evaluate Existing Data.....	9
Task 4 – First Interim Report.....	9
Task 5 – Acquire Data and Develop Methodologies	9
Task 6 – Test and Evaluate Methodology.....	9
Task 7 – Second Interim Report	9
Task 8 – State Evaluation	9
Task 9 – Compile and Archive Data Base	9
Task 10 – Prepare an Aerial Photo Comparison Handbook	9
Task 11 – Submit Final Report	10
CHAPTER 2 Findings	11
LITERATURE REVIEW	11
Introduction.....	11
Fundamental Aspects of Meandering	11
Flow Patterns, Velocity Distributions, and Boundary Shear Stress Distribution at Bends	12
Numerical Models of Flow and Sediment Processes at Bends	15
Meander Planform Characteristics.....	16
Historical and Monitoring Studies of Meandering Rivers	22
Factors Affecting Rates of Meander Change.....	25
<i>Discharge</i>	26
<i>Mobility of Bed Material</i>	26
<i>Sediment Supply</i>	27
<i>Erodibility of Bank Materials</i>	27
<i>Bank Geotechnics</i>	28
<i>Riparian Vegetation and Land-Use</i>	29
<i>Basal Cleanout</i>	30
<i>Human Intervention</i>	30
<i>Overview</i>	31

Styles of Meander Change	34
Conceptual and Empirical Models of Meander Evolution.....	36
<i>Conceptual Models of Meander Migration</i>	36
<i>Numerical Models of Meander Migration</i>	38
Technical Problems Related to Meander Measurement, Characterization, and Monitoring	42
Summary	42
EVALUATION OF ANALYSIS OPTIONS	43
The Johns Hopkins Study	43
<i>Empirical Relationships</i>	44
<i>Bend-Flow Meander Migration Models</i>	44
The Federal Emergency Management Agency Evaluation.....	45
<i>Riverine Erosion</i>	46
<i>Evaluation of Channel Changes</i>	47
<i>Conclusions from the FEMA Study</i>	47
Data Needs	48
<i>Empirical Approach</i>	48
<i>Deterministic Approach</i>	49
Summary	51
CLASSIFICATION AND SCREENING PROCEDURES	51
Objective	51
Classification Concepts.....	51
Classification and Screening.....	52
REGRESSION ANALYSIS	55
Introduction.....	55
Justification of the Classification System	55
Comparison with Other Studies	58
Migration Prediction	60
Frequency Analysis.....	61
Summary	64
THE HANDBOOK	64
Overview.....	64
Application Of Photogrammetry To Meander Migration Analysis	66
Map and Aerial Photography Sources	66
Map and Aerial Photo Comparison Techniques	69
<i>Manual Overlay Techniques</i>	69
<i>Computer Supported Techniques</i>	70
<i>GIS-Based Measurement and Extrapolation Techniques</i>	71
ARCHIVE DATA BASE.....	72
Overview	72
Data Base Structure.....	73
Summary	74
CHAPTER 3 Interpretation, Appraisal, Application	77
OVERVIEW	77
DATA COLLECTION	77
Brice Data Set	78
Schumm Great Plains Rivers Data Set.....	78
Minnesota Rivers Data Set.....	78

Ayres Associates Data Set	79
Other Data Sets	79
Acquisition of Updated Aerial Photos, Maps, and Discharge Data	79
MEASUREMENT PROCEDURES	80
Measurements Using MicroStation®	80
<i>Bankline Delineation</i>	80
<i>Valley Width and Orientation</i>	81
<i>Slope and Sinuosity</i>	82
Measuring Meander Migration	83
<i>GIS Measurement Tool</i>	85
<i>Radius of Curvature</i>	86
<i>Meander Bend Orientation</i>	86
<i>Meander Wavelength and Amplitude</i>	86
<i>Channel Width</i>	87
SCREENING AND CLASSIFICATION PROCEDURES	87
Screening	87
Meander Classification	87
Summary	92
AERIAL PHOTO COMPARISON METHODOLOGY	95
Manual Overlay and Prediction	95
Sources of Error and Limitations	102
<i>Map and Aerial Photo Errors and Limitations</i>	102
<i>Measurement Error</i>	104
<i>Limitations of Overlay Techniques</i>	104
GIS PREDICTOR RESULTS	106
REGRESSION ANALYSIS	111
Expansion	112
Translation and Extension	114
EVALUATION AND TESTING OF THE METHODOLOGY	116
Overview	116
Evaluation Procedure	117
<i>Simple Overlay Technique</i>	117
<i>Computer Assisted (PowerPoint) Overlay Technique</i>	120
<i>ArcView-Based Bend Measurement and Migration Predictor Technique</i>	121
Testing Results	121
<i>Simple Overlay – Sacramento River Site</i>	121
<i>Computer Assisted –Minnesota River Site</i>	122
<i>ArcView Based Measurement and Prediction</i>	122
<i>Statistical Analysis of Test Results</i>	122
Summary of State DOT Comments	125
Alabama	125
Alaska	126
California	126
Maryland	128
Nevada	129
Texas(City of Austin)	129
Wyoming	130
Summary and Planned Response to State Evaluation	131
APPLICATIONS AND IMPLEMENTATION	132
The Handbook	132

The Archive Data Base	133
Implementation	134
<i>The Audience</i>	134
<i>Impediments to Implementation</i>	134
<i>Leadership in Application</i>	134
<i>Activities for Implementation</i>	135
<i>Criteria for Success</i>	136
CHAPTER 4 Conclusions and Suggested Research	137
CONCLUSIONS	137
The Problem	137
The Methodology	138
<i>Literature Review</i>	138
<i>Analysis Options</i>	139
<i>The Handbook</i>	140
The Archive Data Base	143
SUGGESTED RESEARCH	143
REFERENCES	145
APPENDIX A – Bibliography	A-1
APPENDIX B – Data Base Index	B-1
APPENDIX C – Beta Testing Results	C-1

LIST OF FIGURES

Figure 1.	Summary diagram for flow pattern and cross-sectional morphology at a bend apex.....	13
Figure 2.	Generalized sketch of flow patterns and separation at very tight bends.....	14
Figure 3.	Definition of key planform parameters.....	16
Figure 4.	Simple mathematical functions used to represent meander shape.....	17
Figure 5.	Brice classification of single-thread rivers based on the degree and character of sinuosity	21
Figure 6.	Schematic diagram showing in planform features and geomorphic surfaces associated with meander bends	23
Figure 7.	Erosion rate as a function of bend curvature for data from Hickin and Nanson and other authors.....	24
Figure 8.	Controls on river patterns	32
Figure 9.	Styles of change displayed by meander bends	34
Figure 10.	Channel pattern classification devised by Brice.....	53
Figure 11.	Modified Brice classification.....	54
Figure 12.	Modes of meander bend movement.....	56
Figure 13.	Cumulative percentage of Apex Bend Movement in ft/yr.....	57
Figure 14.	Cumulative percentage of Apex Bend Movement in channel widths/yr.....	57
Figure 15.	Migration Rate (MR/W) versus Radius of Curvature/Width	59
Figure 16.	Apex Movement versus Radius of Curvature/Width.....	59
Figure 17.	Apex Movement versus Channel Width.....	60
Figure 18.	Change in Radius of Curvature versus Radius of Curvature/Width (C Sites).....	61
Figure 19.	Cumulative percentage of extension in channel widths per year.....	61
Figure 20.	Cumulative percentage of translation in channel widths per year	62
Figure 21.	Example movement frequencies.....	63
Figure 22.	Hierarchy for Archive Data Base	73
Figure 23.	Example directory for the Archive Data Base.....	74

Figure 24.	General Data spreadsheet containing the existing data and aerial photograph with bend locations for a site on the Brazos River, Texas	75
Figure 25.	Bend spreadsheet containing measured and existing data for a bend on the Brazos River, Texas	76
Figure 26.	Simple and compound channel orientations used in valley slope determinations.....	83
Figure 27.	Measuring meander migration.....	84
Figure 28.	Some of the bend measurements made using the Data Logger	86
Figure 29.	Channel classification and relative stability as hydraulic factors are varied	89
Figure 30.	The range of alluvial channel patterns.....	91
Figure 31.	Idealized long profile from hillslopes and unchanneled hollows downslope through the channel network showing the general distribution of alluvial channel types	92
Figure 32.	Key to classification of rivers in Rosgen's method.....	94
Figure 33.	Longitudinal, cross-sectional, and planform views of major stream types in Rosgen's method	95
Figure 34.	Aerial photograph of a site on the White River in Indiana showing four registration points (circles designated a through d) common to the 1966 aerial photo	96
Figure 35.	Aerial photo of a site on the White River in Indiana showing four registration points common to the 1937 aerial photo in Figure 34	97
Figure 36.	The 1966 aerial photo of the White River in Indiana with the 1937 bankline tracing and registration points.....	97
Figure 37.	Meander loop evolution and classification scheme proposed by Brice.....	98
Figure 38.	Circles that define the average outer banklines from the 1937 aerial photo of the White River site in Indiana.....	99
Figure 39.	Depiction of the bends from 1937 (dotted line) and 1966 (dashed line) outer banklines as defined by best-fit circles	99
Figure 40.	Depiction of the bends from the 1937 (dotted line) and 1966 (dashed line) outer banklines, as defined by best-fit circles, and the predicted location and radius of the 1998 outer bankline circle (solid line).....	100
Figure 41.	Aerial photo of the White River in 1966 showing the actual 1937 banklines (white) and the predicted 1998 bankline positions (black).....	101

Figure 42.	Aerial photograph of the White River site in Indiana in 1998 comparing the predicted bankline positions with the actual banklines.....	102
Figure 43.	Channel migration comparison for the Tombigbee River near Amory, MS	108
Figure 44.	Predicted versus actual bank migration direction.....	109
Figure 45.	Predicted versus actual bend radius and bank migration magnitude	110
Figure 46.	Error in bank migration as a percent of channel width (incremental percent).....	111
Figure 47.	Error in bank migration relative to channel width (cumulative percent).....	112
Figure 48.	Change in Radius of Curvature versus Radius of Curvature/Width (C Sites).....	113
Figure 49.	Change in Radius of Curvature versus Radius of Curvature/Width (C Sites grouped data).....	114
Figure 50.	Bank Erosion Rate versus Channel Width	115
Figure 51.	Change in Channel Width at C Sites	116
Figure 52.	Beta test site on the Sacramento River at Sidds Landing, California	118
Figure 53.	Banklines and circles inscribed on outer bankline positions for a hypothetical channel at 3 different years	119
Figure 54.	Diagram defining the outer bank radius of curvature in Years 1, 2, and 3.....	119
Figure 55.	Beta test site on the Minnesota River at Judson, Minnesota	120
Figure 56.	Comparison of bend radius measurements	123
Figure 57.	Comparison of migration distance measurements	123
Figure 58.	Comparison of ArcView and manual techniques for radius and migration.....	124

LIST OF TABLES

Table 1. Controls on Meander Morphology and Variability of Change	31
Table 2. Apex Movement Statistical Characteristics	58
Table 3. Rates of Extension and Translation	62
Table 4. Years to Migrate One Channel Width	63
Table 5. Sources of Contemporary and Historical Aerial Photographs and Maps	67
Table 6. Classification of Alluvial Channels	88
Table 7. Classification of Channel-Reach Morphology in Mountain Drainage Basins of the Pacific Northwest.....	93
Table 8. Task 8 State Beta Test Participants.....	117

ABSTRACT

This report documents and presents the results of a study to develop a practical methodology to predict the rate and extent of channel migration in proximity to transportation facilities. The principal product of this research was a stand-alone Handbook for predicting stream meander migration using aerial photographs and maps. The Handbook is published separately as *NCHRP Report 533* and can be purchased through the TRB bookstore (trb.org/bookstore). The Handbook deals specifically with the problem of incremental channel shift and provides a methodology for predicting the rate and extent of lateral channel shifting and down valley migration of meanders. The comparison technique developed for this project consists of overlaying channel banklines traced from successive historic maps or photos. Movement of bankline position is then evaluated by measuring the change in radius and movement of the centroid of best-fit circles on the banklines to provide a quantitative estimate of migration distance, rate, and direction over time. Predictions can then be made on the potential position of the river at some point in the future. The process can be completed manually or by using computer photo editing software. In addition, a GIS-based approach was developed with ArcView extensions to streamline the measurement and analysis of bend migration data and aid in predicting channel migration. The ArcView extensions are included in CRP-CD-48, which comes with *NCHRP Report 533*. The report also contains an archive of the data base compiled on *CRP-CD-49* to include all meander site data acquired for this study (141 meander sites containing 1,503 meander bends on 89 rivers in the U.S.). The methodology developed will enable practicing engineers to evaluate and determine bridge and other highway facility locations and sizes and ascertain the need for countermeasures considering the potential impacts of channel meander migration over the life of a bridge or highway river crossing.

ACKNOWLEDGMENTS

This work was sponsored by the American Association of State Highway and Transportation Officials, in cooperation with the Federal Highway Administration (FHWA), and was conducted through the National Cooperative Highway Research Program (NCHRP), which is administered by the Transportation Research Board (TRB) of the National Research Council (NRC).

The research reported herein was performed under NCHRP Project 24-16 by Ayres Associates, Fort Collins, Colorado. Dr. P.F. Lagasse, Senior Vice President, served as Principal Investigator and Dr. S.A. Schumm, Senior Associate, served as Co-Principal Investigator. They were assisted by Dr. L.W. Zevenbergen, Manager River Engineering, Mr. W.J. Spitz, Geomorphologist, and Dr. D.W. Zachmann, Senior Associate.

The advice of Dr. J.C. Brice (formerly USGS) in providing background and explanation of his earlier work for the Research Team, and the assistance of Dr. R. Copeland, U.S. Army Corps of Engineers, Engineering Research and Development Center in providing access to the original Brice data and sharing field data acquired by the USACE at Brice sites are gratefully acknowledged.

Dr. S.A. Schumm contributed to the initial literature survey and his broad experience with the morphology of meandering rivers influenced the direction taken in this research at the outset of the project. Dr. C.R. Thorne's (University of Nottingham, United Kingdom) extensive review of the literature which related the literature on the meandering process to the objectives of this research is specifically acknowledged. Dr. J.L. Briaud, Texas A&M University, provided advice on geotechnical issues over the course of the project and Mr. F.J. Halfen, Vice President for Photogrammetry, Ayres Associates reviewed the photogrammetric applications of the research.

A special acknowledgment is made to the State DOTs of Alabama, Alaska, California, Maryland, Nevada, Wyoming, and the City of Austin, Texas who participated in the Task 8 Beta test of the Handbook and methodology and whose comments led to improvements in both. Mr. J. McConahy of Ayres Associates, Mr. D. Thomas of Mussetter Engineering, Inc. (MEI), and Ms. K. Brennan of the University of Nottingham participated in the internal testing (Task 6) and provided valuable comments on the Handbook and methodology. Dr. C.R. Thorne (United Kingdom) and Dr. R.A. Mussetter (MEI) also reviewed and commented on the Handbook.

The authors would also like to thank Dr. S.A. Schumm (Ayres Associates), Dr. Gary Parker (St. Anthony Falls Hydraulic Laboratory), Mussetter Engineering, Inc., Dr. A.J. Odgaard (Iowa Institute of Hydraulic Research), and Mr. Amir Soltani (Nevada Department of Transportation) for contributing additional data for several sites included in the data base.

The participation, advice, and support of NCHRP Panel members throughout this project are gratefully acknowledged.

METHODOLOGY FOR PREDICTING CHANNEL MIGRATION

SUMMARY

This research accomplished its basic objective of developing a practical methodology to predict the rate and extent of channel migration (i.e., lateral channel shift and down valley migration) in proximity to transportation facilities. The methodology developed will enable practicing engineers to evaluate and determine bridge and other highway facility locations and sizes and ascertain the need for countermeasures considering the potential impacts of channel meander migration over the life of a bridge or highway river crossing.

Based on an extensive literature review it was concluded that the only complete model of a river is the river itself. While the past behavior of a meandering reach is not necessarily indicative of its future behavior, at least the historical record integrates the effects of all the relevant variables as they operate in that location. The conclusions from the literature review are supported by an evaluation of empirical and deterministic (computer modeling) approaches to predicting meander migration. This project confirmed the conclusions of other investigations that because of limitations in data availability and model capabilities, it is extremely difficult to model the detailed time variation of stream movement; however, it is entirely feasible to analyze channel history and infer trends in the stream alignment and average migration rates. At present, empirical approaches are more likely than deterministic approaches to yield a practical methodology that will be useful to practicing engineers. Thus, the research approach for this project emphasized enhancing and using empirical data bases to develop photogrammetric comparison techniques as a basis for predicting meander migration.

The principal product of this research is a stand-alone Handbook for predicting stream meander migration using aerial photographs and maps. The Handbook is published separately as *NCHRP Report 533* and can be purchased through the TRB bookstore (trb.org/bookstore). The Handbook deals specifically with the problem of incremental channel shift and provides a methodology for predicting the rate and extent of lateral channel shifting and down valley migration of meanders. The methodology is based, primarily, on the analysis of bend movement using map and aerial photo comparison techniques; but frequency analysis results are provided to supplement the comparative analysis. The methodology enables practicing engineers to evaluate the potential for adverse impacts due to incremental meander migration over the design life of a bridge or highway river crossing and ascertain the need for countermeasures to protect the bridge from any associated hazards.

An essential first step in applying the methodology is screening and classifying the river reach(s) under consideration. This project verified and extended the results of earlier research which indicated that meandering channels that do not vary significantly in width are relatively stable, whereas channels that are wider at bends are generally more active. As presented in the Handbook, this simple stratification of meanders is of value to the bridge engineer as a screening procedure, allowing preliminary identification of meanders that are very stable. As a result, this class of equiwidth meandering streams can be given a lower priority or eliminated from further analysis. The more actively meandering streams can be analyzed by the photogrammetric comparison techniques presented in the Handbook.

The key to application of the methodologies presented in the Handbook is obtaining time sequential aerial photography (or maps) of the meander site to be analyzed. Historical and contemporary aerial photos and maps can be obtained inexpensively from a number of Federal, State, and local agencies. The Internet provides numerous sites with links to data resources and sites having searchable data bases pertaining to maps and aerial photography. It is this ready availability of aerial photography resources that makes the methodologies presented in the Handbook powerful and practical tools for predicting meander migration.

The comparison of sequential historical aerial photography, maps, and surveys provides an easy and relatively accurate method of determining migration rates and direction. The amount of detail available for analysis increases as the length of time between successive maps or photos decreases. However, a longer period of record for comparison will tend to "average out" anomalies in the record and provide a better basis for predicting meander migration by extrapolation. Abrupt changes in migration rate and major position shifts can often be accounted for by analyzing maps and photos for land use changes, and nearby stream gage records can be examined for extreme flow events. Predictions of migration for channels that have been extensively modified or have undergone major adjustments attributable to extensive land use changes will be much less reliable than those made for channels in relatively stable watersheds.

The overlay comparison technique developed for this project consists of overlaying channel banklines or centerlines traced from successive historic maps or photos. The maps and photos are first enlarged or reduced to a common scale. Then, common reference points are identified, and the banklines of the meander bend are delineated on successive photos. The banklines are then overlain on each other by matching the common reference points. The overlain bankline positions can then be evaluated by measuring the change in radius and movement of the centroid of best-fit circles on the banklines to provide a quantitative estimate of migration distance, rate, and direction over time. Using the information and data obtained from this type of analysis, predictions can then be made on the potential position of the river at some point in the future.

This process can be completed manually by tracing bends and inscribed circles on mylar overlays. However, the availability of computer photo editing software provides an alternative approach for performing the photo comparison techniques outlined above. For example, photo comparison and prediction can take advantage of the photo editing capabilities in Microsoft Word or PowerPoint. In addition, computer aided design (CAD) software, such as AutoCAD and Bentley's MicroStation, can be used to perform the photo comparisons with greater precision and accuracy, especially when the maps and photos are geo-referenced.

The geo-referenced photos and banklines and associated data can be imported into a Geographic Information System (GIS) such as ArcView, a GIS and mapping software package developed by Environmental Systems Research Institute Inc. (ESRI). An ArcView extension, the Data Logger, a menu-driven circle template methodology was developed for this project to streamline the measurement and analysis of bend migration data and aid in predicting channel migration. The Channel Migration Predictor, another custom ArcView extension, uses the data archived by the Data Logger in predicting the probable magnitude and direction of bend migration at some specified time in the future. The ArcView extensions are included in CRP-CD-48, which comes with *NCHRP Report 533*.

The Data Logger provides users with a quick and easy way to gather and archive river planform data. The bend delineation points for each bend and each historical record are archived

to provide a graphical record of the user's interpretation of each bend. For each river bend and each historical record, the Data Logger records various river characteristics which are organized by river reach and recorded in a table identified by the reach name. Finally, the Channel Migration Predictor examines a table of river reach data for several bends and two or three historical records per bend, and then predicts rates of change in bend radius and bend center position for some time in the future.

Another deliverable for this project is an archive of the database compiled on [CRP-CD-49](#) to include all meander site data acquired for this study. The CD-ROM archives contain the Excel workbooks, MicroStation files, 1990s and historic (where applicable) aerial photos, and the topographic maps for each site in digital file format. The database includes 141 meander sites containing 1,503 meander bends on 89 rivers in the U.S. The data for each meander site is compiled in Microsoft Excel workbooks. There are multiple spreadsheets within each of the workbooks. A General Data spreadsheet, contains the general information compiled from various sources and an aerial photo showing the site limits and the included meander bends. There are individual spreadsheets, designated by the bend number, which contain detailed historic data for each of the bends of the site. A summary spreadsheet contains all the measured data for all the bends of the site.

The data base includes four spreadsheets that cross-reference each data site by the (1) source of the data, (2) stream classification, (3) river name, and (4) state in which the site is located. This format permits cross-referencing and provides a simple and useable approach to searching the data base. With this archive data set, future researchers will have a readily accessible data base in a very useable format for a variety of studies. These studies could include additional empirical analyses, more complex regressions based on the archive data, and research to develop more practical deterministic models of the meandering process.

Much work remains to be done before the potential impacts of meander migration on transportation infrastructure can be predicted with certainty and ease using statistical or deterministic methods. While the results of this research, comparative analysis based on maps and aerial photography, could be viewed as an interim approach, it is not likely that this approach will be replaced by more sophisticated analytical techniques in the near future. The techniques presented in the Handbook will always be useful at the reconnaissance level or as a "reality check" on other approaches to solving the problem of predicting meander migration.

The Handbook contains applications guidance and examples for the analytical products of this research, map and aerial photograph comparison techniques and guidelines to predict channel migration in proximity to transportation facilities. The Handbook provides the methodology in a stand-alone package with guidance and examples to facilitate ease of application. This methodology will be useful in reconnaissance, design, maintenance and inspection of highway facilities, and will help reduce the cost of construction, repair, rehabilitation and countermeasures for lateral channel instability. The screening procedure to identify stable meandering stream reaches will ensure that engineering and inspection resources are not allocated to locations where there is little probability of a problem developing. The end result will be a more efficient use of highway resources and a reduction in costs associated with the impacts of channel migration on highway facilities.

INTRODUCTION AND RESEARCH APPROACH

PROBLEM STATEMENT AND RESEARCH OBJECTIVES

Rivers prone to channel migration may be spanned by structures and paralleled by fixed highway alignments and appurtenances. Channel migration (alluvial river meander, planform deformation) is a major consideration in designing bridge crossings and other transportation facilities in affected areas; it causes the channel alignment and approach conditions present during construction to deteriorate as the upstream channel location changes. Channel migration can result in the following: (a) excess bridge pier and abutment scour, (b) threats to bridge approaches and other highway infrastructure, (c) worsened debris problems, and (d) obstructed conveyance through bridge openings.

Channel migration is typically an incremental process. On meandering streams, the problem at a bridge site may become apparent two or three decades after the bridge is constructed. Channel migration is often evident throughout large sections of a drainage basin; it is not localized in the vicinity of a bridge. It is a natural phenomenon that occurs in the absence of specific disturbances, but may be exacerbated by such basin-wide factors as land use changes, gravel mining, dam construction, and removal of vegetation. Remedial action such as constructing spurs or installing bank protection becomes increasingly expensive or difficult as the channel migrates. A methodology is needed to evaluate the potential for channel movement and predict future channel migration.

Channel migration includes lateral channel shift (expressed in terms of distance moved perpendicular to the channel center line, per year) and down valley migration (expressed in distance moved along the valley, per year). Engineers are concerned with predicting channel migration as it moves through the bridge elements (piers and abutments) or endangers other highway infrastructure during its design life. The role of multiple reaches and subwatersheds in predicting factors affecting the rates of lateral channel shift and down valley migration is also important to the understanding of channel migration in the vicinity of transportation facilities, as is the impact the transportation infrastructure itself has on those rates. In addition, any methodology for predicting channel migration rates will need to consider factors that affect natural channel migration rates such as the size and frequency of formative river flows, and past, present, and possible future disturbances to that channel migration.

The basic objective of this research was to develop a practical methodology to predict the rate and extent of channel migration (i.e., lateral channel shift and down valley migration) in proximity to transportation facilities. The methodology should enable practicing engineers to evaluate and determine bridge and other highway facility locations and sizes and ascertain the need for countermeasures considering the potential impacts of channel meander migration over the life of a bridge or highway river crossing.

The methodology could be applied to locate and design a new bridge or highway facility to accommodate anticipated channel migration or to evaluate the risk to existing facilities, and if necessary, to determine the need for and design countermeasures against the effects of channel

migration. A prediction of channel migration could also be used to alert bridge inspection personnel to the potential for channel change that could affect the safety of a bridge.

SCOPE OF RESEARCH

Predicting channel migration requires consideration of both local and system-wide factors. The morphology and behavior of a given river reach is strongly determined by the sediment and water discharge from upstream. Therefore, any significant modification of sediment load and water discharge, as a result of human or natural events, will impact local rates of channel change. Even without changes to the supply of water or sediment, lateral migration can occur and adversely impact highway structures.

Locally, the distribution of velocity and shear stress and the characteristics of bed and bank sediment will control channel behavior. Therefore, local channel morphology such as dimensions (width, depth, meander wavelength and amplitude), pattern (sinuosity, bend radius of curvature), shape (width-depth ratio), and gradient will not only reflect upstream controls, but will also provide information on the direction and rate of channel migration. For example, highly sinuous, equal-width channels are relatively stable, whereas less sinuous channels of variable width may migrate rapidly.

While geomorphologists may view channel stability from the perspective of hundreds or thousands of years, for highway engineering purposes, a stream channel can be considered unstable if the rate or magnitude of change is such that the planning, location, design, or maintenance considerations for a highway crossing are significantly affected during the life of the facility. The kinds of changes that are of concern are: (1) lateral bank erosion, including the erosion that occurs from meander migration; (2) aggradation or degradation of the stream bed that progresses with time; and (3) short-term fluctuations in streambed elevation that are usually associated with the passage of a flood (scour and fill). This research is concerned specifically with lateral channel instability (including down valley migration) resulting from meander migration.

The original scope of this research envisioned the following approach:

- Enhance existing data sets by acquiring recent aerial photography at selected study sites and conduct field work, if necessary, to obtain hydraulic and geotechnical/soils characteristics of selected sites.
- Analyze the enhanced data sets with photogrammetric comparisons which in general encompass the time periods of the 1930s, 1960s, and 1990s. Determine and analyze the geotechnical characteristics of bed and bank materials at selected sites, emphasizing descriptors of bankline erodibility and floodplain characteristics.
- Develop a quantitative screening procedure to identify stable meandering reaches. This information would be significant to both bridge design engineers and bridge inspectors and would provide a basis for concentrating design and inspection resources on less stable problem reaches.

- Develop quantitative multiple regression or other statistical relationships for predicting direction, location, and rate of meander migration in unstable meandering stream reaches. Support these empirical relationships with an overall applications methodology, perhaps in spread sheet and graphical (CAD) formats.

Following a literature review, documentation of case histories on meander migration and assembly and evaluation of existing data, an Interim Report was submitted for Panel review in September 1999. At a Panel meeting in November 1999, the Panel concurred with the Research Team's recommendation to eliminate the field work originally proposed. Direct costs originally allocated to field work were reallocated to other activities. The Interim Report suggested that the Panel consider increasing the project scope to include two additional activities:

- Develop a map/aerial photograph comparison Handbook for predicting meander migration as a stand-alone deliverable.
- Extend the scope to include a methodology to predict avulsive or catastrophic channel change in addition to incremental shift.

In October 2000, NCHRP informed the Research Team that the Panel had requested continuation funds at the conclusion of the November 1999 interim meeting. The AASHTO Standing Committee on Research had reviewed the Panel's request and during the March 2000 meeting approved the request. The Panel's objectives for the continuation funds were as follows:

- Develop a map/aerial photograph comparison Handbook
- Analyze an additional 500 river meander sites
- Compile a data base and archive on a CD-ROM data from all sites analyzed

The Panel did not support the suggestion to include a methodology to predict channel avulsion in the scope of work.

A proposal for continuation funding was submitted to NCHRP and the Panel in October 2000. The PI met with the Panel at TRB in December 2000 and comments from the Panel were received in February 2001. A revised Research Work Plan in March 2001 incorporated the additions to the scope and budget and revised the schedule from 30 months to 48 months for project completion.

RESEARCH APPROACH

The fluvial processes involved in predicting meander migration are very complicated and the variables of importance are difficult to isolate. The major factors affecting alluvial stream channel forms are: (1) stream discharge (magnitude and duration), temperature, viscosity; (2) sediment load, including types and caliber of sediments; (3) longitudinal valley slope; (4) bank and bed resistance to erosion; (5) vegetation; (6) geology, including bedrock outcrops, clay plugs, changes of valley slope; and (7) human activity. In an analysis of flow in alluvial rivers, the flow field is further complicated by the constantly changing discharge. Significant variables are, therefore, quite difficult to relate mathematically. It is often necessary to list measurable or computable variables, which effectively describe the processes occurring, and then to reduce the

list by making simplifying assumptions and examining relative magnitudes of variables. This means that it is necessary to strive toward an acceptable balance between accuracy and limitations posed by data needs and analytical complexity.

Many laboratory and field studies have been carried out in an attempt to determine the variables controlling river response. To the present time, the problem has been more amenable to an empirical solution than an analytical one. Computer solutions to complex hydraulic problems have extended the range of fluvial process problems that can be solved analytically; but simplifying assumptions are still required. While the mathematical complexity of the analytical solution may be justified for research purposes, empirical approaches may produce results of greater utility to practicing engineers.

In addition to channel and bank characteristics, floodplain characteristics must also be incorporated into an analysis procedure. The floodplain characteristics that should affect meander migration include geologic controls, alluvial deposits and topographic variability. Geologic controls include bedrock outcrops and erosion resistant features along the valley sides. Alluvial deposits frequently include oxbows, meander scrolls and scars, and clay plugs, each with different erodibility characteristics. Topographic variability that should be considered include the cross valley slope of the adjacent floodplain and whether channels are migrating into alluvial deposits or into adjacent hillslopes.

After careful review of empirical and deterministic (physical process mathematical modeling) approaches to predicting meander migration it was concluded that empirical approaches are more likely than deterministic approaches to yield a practical methodology that will be useful to practicing engineers. Thus, the research approach emphasized enhancing and using empirical data bases to develop photogrammetric comparison techniques and predictive multiple regression or other statistical relationships which include descriptors of, or surrogates for, bankline erodibility and floodplain characteristics.

The approach was essentially empirical. The basis for suggesting this approach was two-fold:

1. The limited success, to date, achieved in using bend-flow models to predict the direction, location, and rate of bank erosion and meander migration, and
2. The inherent complexity of bend-flow modeling. For State DOT's, the primary users of the results of this research, empirical approaches are much more likely to provide a methodology that can and will be used in the field by practicing highway hydraulic engineers.

In outline, the approach consisted of:

- Conduct a complete and thorough literature review using standard reference sources, and update and critically review literature searches on meander migration previously completed by members of the Research Team.
- Access and evaluate a number of existing data sets that contain time-sequential aerial photography, stream gaging data, and field measurements of hydraulic and geomorphic variables.

- Contact state, federal, other agencies, and researchers who have assembled similar data bases to collect data to supplement and expand the existing data sets.
- Choose a broad distribution of sites geographically so that regional climate, geology, and geomorphology are represented.
- Enhance existing data sets by acquiring recent aerial photography at selected study sites and obtain data on hydraulic and geotechnical/soils characteristics.
- Analyze the enhanced data sets with photogrammetric comparisons which in general encompass the time periods of the 1930s, 1960s, and 1990s. Determine and analyze the geotechnical characteristics of bed and bank materials at selected sites, emphasizing descriptors of bankline erodibility and floodplain characteristics.
- Develop a quantitative screening procedure to identify stable meandering reaches. This information would be significant to both bridge design engineers and bridge inspectors and would provide a basis for concentrating design and inspection resources on less stable problem reaches.
- Develop a classification system for river/meander types to support stratification of the data base.
- Develop a stand-alone Handbook for map/aerial photograph comparison techniques for measuring and predicting meander migration. Support the comparison techniques with an overall applications methodology in GIS format.
- Develop a frequency (probability) analysis for all meander classes with sufficient data to test the reasonableness of results obtained by comparison techniques.
- Compile and archive a data base on CD-ROM which includes all meander site data acquired for this study.
- Conduct the necessary testing and evaluation, both internally and with State DOT's, and revise the methodology as necessary.
- Develop a detailed plan and recommendations for incorporating the results of this research in ongoing FHWA/National Highway Institute technology transfer programs.

Considering the research approach outlined above, the following specific tasks will accomplish the objectives of NCHRP Project 24-16. These tasks parallel those suggested in the Research Project Statement.

Task 1 - Literature Review

Conduct a critical review of published and unpublished literature to determine the existing state of knowledge and to identify sources of data pertaining to channel migration. Conduct a complete and thorough literature review on meander migration using such standard sources as GeoRef for the geomorphic-geologic literature and Water Resources Abstracts for the engineering literature. Critically review the literature on deterministic modeling approaches to validate the proposed methodology.

Task 2 - Document Case Histories

Contact state, federal, and other appropriate agencies to develop a list of documented case histories and to collect information on channel migration throughout North America.

Task 3 - Assemble and Evaluate Existing Data

Access and evaluate the existing data bases and develop additional data on meander migration as described in Task 2. By correlating these data sets, determine the extent to which the full range of empirical data necessary to the research approach already exists.

Task 4 - First Interim Report

Prepare and submit an Interim Report. The Interim Report will include a detailed outline of the proposed methodology, document the results of Tasks 1 through 3, and update the Work Plan for completing the project.

Task 5 - Acquire Data and Develop Methodologies

Obtain the necessary data and aerial photography, integrate that data with existing data sets, and develop a methodology which meets project objectives.

Task 6 - Test and Evaluate Methodology

Test the methodology using independent data sets and recalibrate as appropriate. Evaluate the accuracy of the methodology and discuss the implications for application.

Task 7 - Second Interim Report

Prepare and submit a second interim report which will include analysis of the data, a draft of the map/aerial photograph comparison Handbook and draft documentation of the GIS based measurement and extrapolation techniques.

Task 8 - State Evaluation

Provide the methodology to five states for their independent assessment and report the results. Modify the methodology, as appropriate.

Task 9 - Compile and Archive Data Base

Compile and archive the data base on a CD-ROM (or several CD-ROMS) which will include all meander site data acquired for this study.

Task 10 - Prepare an Aerial Photo Comparison Handbook

Prepare the Handbook following National Highway Institute (NHI) standards. As a minimum, the Handbook will cover the following topics:

- Screening and classification of meander sites

- Sources of mapping and aerial photographic data (e.g., the MSN TerraServer Web site or the USGS EROS Data Center)
- Basic principles and theory of aerial photograph comparison (e.g., scale, distortion, etc.)
- Simple overlay techniques
- GIS or computer supported techniques (e.g., software such as ArcView)
- GIS based measurement and extrapolation techniques
- Sources of error and limitations
- Illustrated examples and applications
- Supplementing photo/map comparison techniques with regression results

Task 11 - Submit Final Report

Submit a final report documenting the entire research effort. The map/aerial photograph comparison Handbook will be a stand-alone document. The final report will contain a detailed plan and recommendation for incorporating the results of this research in ongoing FHWA National Highway Institute technology transfer programs and courses.

CHAPTER 2

FINDINGS

LITERATURE REVIEW

Introduction

The literature review process resulted in about 1,300 citations relating to the keyword 'meander.' However, initial examination of the titles, keywords and abstracts of the cited literature revealed that a great number of these articles were not directly relevant to this study, in general, and practical prediction of meander migration, in particular. In screening the large number of initial citations, reviewers sought to retain the key articles necessary to underpin a study of meander migration, and target the literature review on acquiring the knowledge contained in those articles for use when evaluating the relative merits of different prediction approaches. In this context, the articles selected in the targeted review covered a range of issues and aspects including:

- Fundamental aspects of meandering in rivers and other fluid shear flows
- Flow patterns, velocity distributions, and boundary shear stress distributions at bends
- Numerical models of flow and sediment processes at bends
- Meander planform characteristics
- Historical and monitoring studies of meander evolution
- Factors affecting rates of meander change
- Styles of meander change
- Conceptual and empirical models of meander evolution
- Numerical models of meander migration
- Technical problems related to meander measurement, characterization, and monitoring

Articles excluded from the targeted review included those dealing with detailed fluid dynamics, geologic and sedimentary aspects of meandering rivers and their alluvial deposits, and material that was either too highly theoretical to apply in practice or lacked the sound basis in engineering science necessary to make it reliable. In conducting the review, particular attention was paid to careful consideration of the advantages and disadvantages of deterministic, probabilistic, analytical, and empirical approaches to meander migration prediction.

Fundamental Aspects of Meandering

A meander is defined as "A loop-like bend in a river characterized by a river cliff on the outside of the curve and a gently shelving point bar on the inner side of the bend" (1). Meanders are ubiquitous to the channels of creeks, streams, and rivers spanning several orders of magnitude in scale. In fact, meandering is not confined to rivers (2, 3, 4), but has also been identified in a wide variety of other fluid shear flows including:

- Capillary jets and rivulets running down roughened plates
- Human blood stream

- Water flowing over ice
- Ocean currents
- Planetary jet stream
- Channels carved by molten lava on the Moon
- Sub-surface water flows on Mars

The propensity for flowing fluids to meander indicates that this behavior is inherent to shear flows and cannot be attributed solely to local non-uniformity of sediment transport or bank erosion, although both are necessary for meandering in alluvial rivers. It is clear that meanders can form almost spontaneously given the right conditions. For example, Davis (5) observed meanders to develop very quickly due to the action of swift flow on the bed of a reservoir following rupture of the dam.

While the precise cause of meandering remains undefined, it seems that meandering stems from the influence on the time-averaged flow field of coherent flow structures with dimensions approximating those of the channel cross-section (6). These large eddies induce a sinuous path in the line of the maximum velocity filament and surrounding flow field that is subsequently strengthened by positive feedback between curvature of the flow and skew-induced secondary currents of Prandtl's first kind (7). Provided that the bed material is mobile, asymmetry in the velocity and boundary shear stress distributions rapidly leads to the generation of pools, riffles, and alternate bars (8) though if the channel banks are unerodible, the channel itself may remain straight indefinitely (9). In this respect, bank erosion is a necessary condition for meander initiation, although it is not a cause itself (10). In streams with erodible banks, the sinuous path of maximum velocity filament drives a matching pattern of deformation in the banklines that marks the onset of channel meandering (11, 12, 13). The point at which the channel transitions from straight or sinuous to meandering is open to debate. Leopold and Wolman (14) suggested that a sinuosity 1.5 marks the lower boundary for true meandering, although most later authors agree on a somewhat lower threshold sinuosity of 1.3.

While there is still much to be explained about the fundamental causes and mechanisms of meandering, it is clear from the literature that meandering is a natural attribute of most alluvial streams. It follows that meandering behavior should be expected in alluvial streams and must be accounted for in the design, siting, and inspection of highway bridge crossings on alluvial streams.

Flow Patterns, Velocity Distributions, and Boundary Shear Stress Distributions at Bends

The complex nature of flow at bends caused by curvature effects has been recognized and commented on for over a century (15, 16). Early investigators quickly established that the dominant flow structure at a bend is helical flow generated by the combination of primary and secondary currents. Secondary currents occur in the plane normal to the primary flow direction and appear at bends due to skewing of a portion of the cross-stream vorticity into the long-stream direction (7, 15). The main, skew-induced secondary cell drives fast, near-surface water outwards at a bend and carries slow, near-bed water inwards. During most of the twentieth century, it was believed that helical flow associated with skew-induced secondary circulation occupied the entire cross section at the bend apex (see for example (17, 18)). But in the early

1970s, direct measurements of primary and secondary velocities at bends revealed that a small, counter-rotating cell may exist next to the outer bank (19). This 'outer bank cell' interacts with the main, skew-induced circulation to generate elevated velocities and high local boundary shear stresses on the lower bank and the bend adjacent to the outer bank (7, 20). It is the high intensity of flow attack that undercuts the bank and scours the bed at the toe to promote erosion, instability, and rapid bank retreat (21, 22). In turn, it is this rapid retreat of the outer bank that enables active meanders to shift and migrate.

Even after the existence of the outer bank cell became widely accepted, the belief persisted that helical flow extended to the inner bank (see for example (23, 24)). However, in the late 1970s and 1980s, theoretical analyses, coupled with detailed measurements of primary and secondary velocities around the inner bank, questioned this belief (25). Theory and measurement indicated that, over the upper part of the point bar, topographic steering of the flow leads to secondary currents directed radially outwards through the whole flow depth (26). It is this outward flow that causes erosion of the outer bank early in the bend (20) and encourages the filament of maximum velocity to cross to the outer bank earlier than is predicted by most analytical models, because the models ignore the convective acceleration terms in simplified versions of equations of motion for curved flows (27). Improved understanding of the flow pattern near the inner bank is also important because it explains why the characteristic cross-profile of the point bar is non-linear. Natural point bars consist of a flat upper surface, which is dominated by outward flow (termed the point bar platform by (25)), separated from a steep lower surface, which is dominated by helical flow (termed the point bar face), and by a sharp depositional edge (termed the point bar crest).

Taken together, the results of theoretical and empirical studies performed in the 1970s and 1980s yield a picture of bend flow-morphology interactions that is more complex than originally envisioned, but which is consistent with observed forms and features (Figure 1).

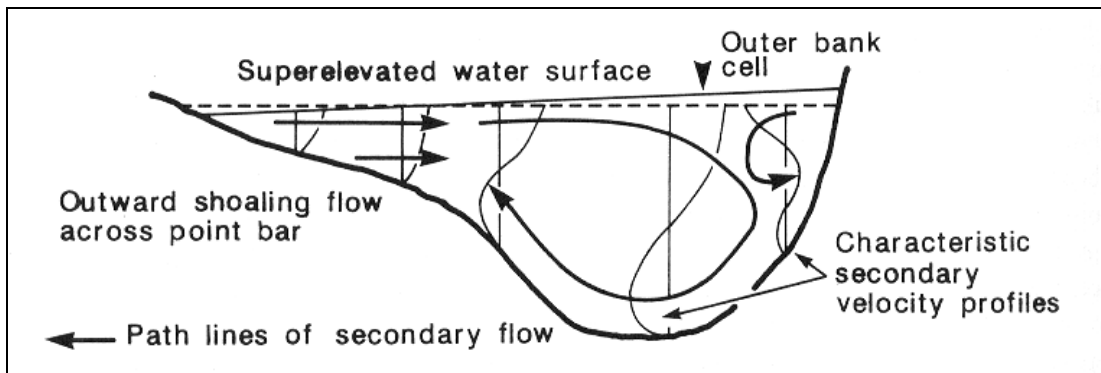

Figure 1. Summary diagram for flow pattern and cross-sectional morphology at a bend apex (adapted from (28)).

As bends evolve through time, they tend to increase in amplitude and decrease in radius. Tightening of the bend produces significant changes in the flow pattern. In a series of flume and pipe experiments, Bagnold (29) noted that a zone of separation develops at the inner bank downstream of the bend apex, reducing the effective width and concentrating downstream flow against the outer bank around and downstream of the bend exit. He also noted that development of inner bank separation was associated with an increase in the propensity for meanders to migrate downstream while maintaining their shape and occurred for bend radius of curvature to width ratios (R_c/W) of the order of 2 to 3.

Bagnold's results indicated that an R_c/W of 2 to 3 corresponds to a minimum in the energy losses generated by the bend, a finding that was subsequently supported on theoretical grounds by Chang (30) who found that the river does least work in turning for R_c/W of approximately 3. Bagnold's laboratory results were also supported by the field measurements of Leeder and Bridges (31) who ascribed inner bank separation to a Froude number effect, although this cannot actually be correct as Bagnold noted the same pattern of separation at bends in closed conduits where Froude number has no meaning as there is no free surface.

If the bend becomes very tight, a second zone of separation develops at the outer bank (29). In Bagnold's experiments, this zone had the effect of 'stalling' the spatially organized pattern of helical flow, resulting in intense turbulence and massively increased energy losses. Outer bank separation in tight bends of meandering rivers has also been widely observed (28) and leads to marked changes in the distribution of boundary shear stress and bank retreat. Bank erosion in the zone of separation may produce rapid local retreat upstream of the bend apex that may quickly generate a 'double-headed' bend (32), while in heavily sediment-laden streams deposition of a bar in slackwater areas associated with stalled flow can lead to flow deflection and erosion of the inner bank and potential bend abandonment by chute cutoff (8, 33, 34). In either case, development of separation of flow at the outer bank marks a profound change in the evolution and migration pattern of the bend. Outer bank separation seems to occur at a lower R_c/W than that for inner bank separation, and Markham and Thorne (28) proposed generalized sketches of flow separation at bends on this basis (Figure 2).

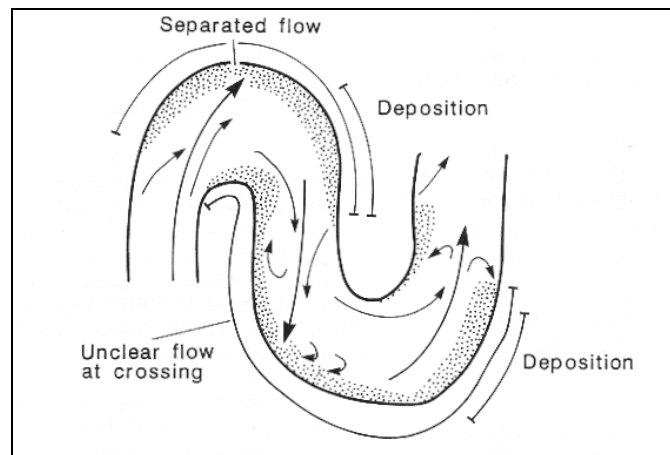

Figure 2. Generalized sketch of flow patterns and separation at very tight bends.

Changes in bend geometry and migration rate may be largely explained by the patterns of flow at bends and the way in which curvature effects first strengthen and later modify velocity and shear stress distributions as the bend evolves. Hey (35) provides a succinct review of bend-flow morphology relations that adequately covers the main phenomena. In long, slightly curved bends curvature effects are weak, but helical flow strengthens as bend amplitude grows and radius shortens. When flow at the inner bank separates, meander evolution switches from growth to downstream migration. If outer bank separation occurs, the bend may divide in two (double heading) or cut off. Thresholds in behavior may be related to R_c/W , which tends to decrease through time as the bend evolves. R_c/W ratios between 20 and 4 characterize bend growth, R_c/W values of 2 to 3 characterize migration, and values less than 2 characterize double heading or abandonment (36).

Numerical Models of Flow and Sediment Processes at Bends

Many attempts have been made to model flow and sediment processes at bends, and the fundamental approaches that can be adopted have been fully reviewed in papers, texts, and research monographs such as Henderson (18), Parker et al. (37), Elliott (38), and Ikeda and Parker (39). Many models stem from the early work of Engelund (40) who produced a simplified set of equations describing flow at a bend that were amenable to analytical solution. In particular, Engelund's approach was developed and refined by Odgaard (41, 42) to produce a model that could be applied in the context of engineering analysis of meandering rivers. Odgaard's work is particularly significant because he went on to use the implications of his analytical bend-flow model to underpin an empirical model for bank retreat at bends (43, 44). However, Engelund's approximations of the equations of motion for curved flow were heavily criticized by Dietrich et al. (45) because he ignored certain terms for convective accelerations, which turned out to be crucial to generating outward secondary flow near the inner bank. The model of Smith and McLean (27) demonstrated that these terms were not negligible and their omission seriously limited the capability of Engelund's model (or other models derived from it) to represent bend flow properly. However, application of the Smith and McLean model demands very accurate data on water surface topography. It is sensitive to errors of only ± 0.04 inches (± 1 mm) in water-surface elevation, ruling it out as a tool for engineering analysis or design in real alluvial streams.

A number of authors have attempted to produce simpler models suitable for engineering applications by modifying more complex models. This approach can be illustrated by the work of Garcia et al. (46) who developed the model of Ikeda et al. (47) specifically to provide "*A Tool for Stream Management and Engineering*." They combined the 2-dimensional, depth-averaged St. Venant equations for shallow flow with the depth-averaged continuity equation to produce a function that gives the depth-averaged downstream velocity at every point in the channel. Knowledge of the spatial distribution of depth-averaged velocity can be used to drive a morphological model capable of predicting bed scour and the spatial distribution of bank retreat. However, the practical utility of Garcia et al.'s model comes at the price of accepting limiting assumptions that rule out its application to many alluvial rivers. For example, boundary conditions specify a constant channel width maintained by parallel migration of inner and outer banks, a linear, steady-state, cross-stream bed slope, and a bend radius that is large compared to

the channel half-width. There are theoretical difficulties too. For instance, sediment continuity is neglected so that an important reality check is eliminated.

Cherry et al. (48) evaluated the performance of Garcia et al.'s (46) model in forecasting the behavior of bends at 26 sites selected from the Brice (49) data set on planform shifting of meanders in alluvial streams. They discovered that additional data collection was essential to support application of the computational model, which would limit the applicability of the approach to sites where detailed data either pre-existed due to earlier academic research or could be collected through intensive fieldwork. The results of model application were not encouraging and they concluded that prediction of meander migration based on a computational bend-flow model was not feasible at that time (mid-1990s). (For further discussion, see the section on Evaluation of Analysis Options).

Meander Planform Characteristics

Meanders are best appreciated and described when viewed from above and there has been a great deal of study directed at defining and analyzing meander planform. It is in terms of planform shape and dimensions that a meander bend is defined. Figure 3 illustrates the most commonly used parameters of bend geometry.

Planform studies have attempted to characterize the shape of an individual bend or pair of bends when viewed from above using a variety of mathematical functions. Early investigators examined circular, parabolic, and sine curves (Figure 4) before deciding that a sine-generated curve best resembled an idealized meander (50).

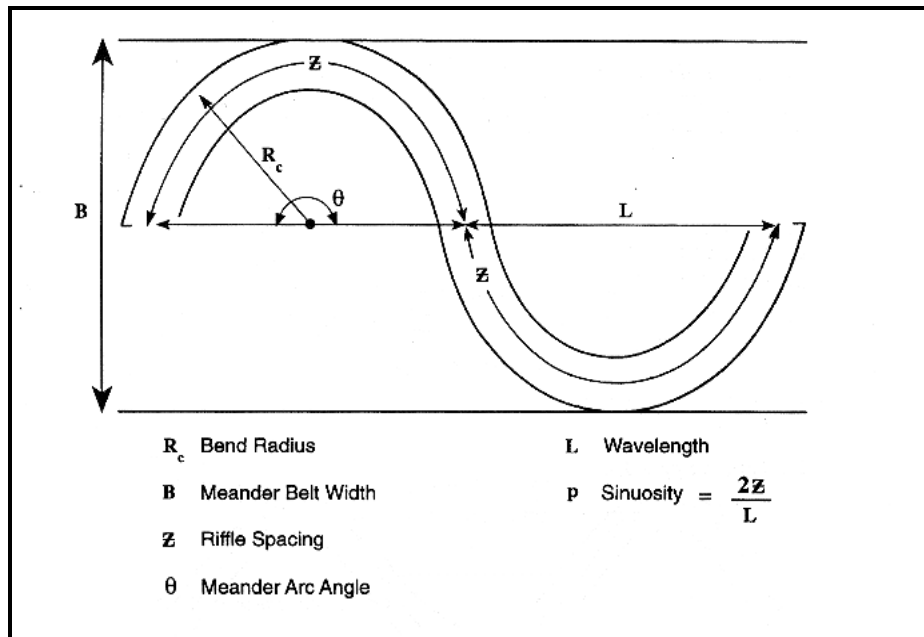

Figure 3. Definition of key planform parameters.

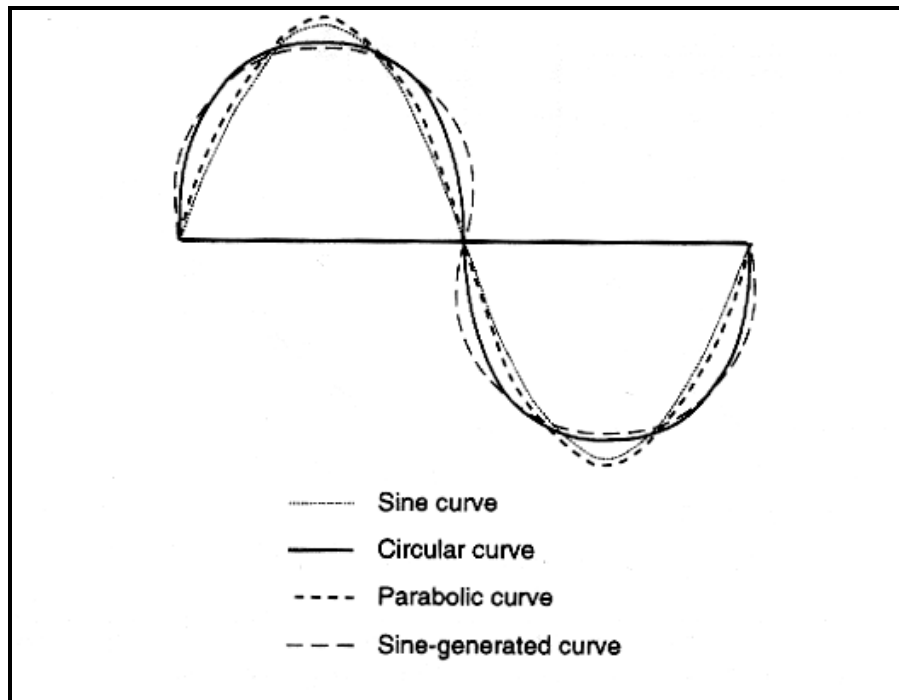

Figure 4. Simple mathematical functions used to represent meander shape.

However, Leopold and Langbein also noted that, unlike the simple geometric shapes they investigated, real meander bends are rarely symmetrical. Much subsequent work [well reviewed by Ferguson (51) and Carson and Lapointe (52)] has failed to produce a function that describes meander form to the general satisfaction of academics. It is recognized that attempts to find a complex function capable of accurately representing idealized planform for a meander are probably futile (53, 54). Carson and Lapointe (52) recommend that sine-generated models of meander shape be discarded but do not suggest an alternative function that should be used. Although Chang (55) reports on flow paths and migration of symmetrical bends, Whitesell et al. (56) concluded that asymmetry is inherent to meander bends. The problem is eloquently captured by Weihaupt (57) who stated:

"After working with river meanders for a number of years, one cannot help but believe that a common geometry must underlie all meanders. For any individual meander loop that is examined, it is possible to find one geometric form, which is mathematically definable, that will fit the feature. The difficulty arises when the investigator goes on to the next meander loop in the river, and finds that the geometric shape selected for the previous meander loop does not fit the next one under study. Nevertheless, a new mathematically definable geometric form can be found which will fit the next meander loop. But, of course, this second geometric form will fit neither the first or a third meander loop. The reason for the inability to fit one geometric form to all meander loops is that the size and configuration of individual meander loops appear to be unique to that meander loop. No two meander loops in nature are absolutely identical."

In light of this, it seems wise to characterize meander bend geometry by a simple function such as a circular arc, but recognize that the true bend forms in meandering channels will inevitably deviate and scatter around this simple representation.

In fact, few natural meanders display a classic or idealized planform in any case, due to non-uniformity in the bed and bank materials (58) or variation in entrance flow conditions (59). For example, studies of the Lower Mississippi by Fisk (58) demonstrated the influence of clay plugs, in-filling cutoff bends, and sand deposits found in abandoned former channel courses on bend form and evolution. Lower Mississippi bend forms and dynamics were further examined by Schumm and Thorne (60), who identified no less than five different effects a clay plug could have on meander form and migration. Schumm et al. (61) expanded on the earlier work by identifying and discussing the nature and causes of variability in the form of the Lower Mississippi between Cairo and Old River.

Studies of the planforms of longer, meandering reaches were initially based on mapping, and Dort's (62) investigation of historical changes to the Kansas River and its tributaries between 1857-1868 and 1976 provides an excellent example of what can be achieved. However, analytical work based on historical maps is hampered by uncertainties concerning the accuracy of the maps and the criteria used in representing the banklines of the river. Hooke and Redmond (63) provide a comprehensive review of these issues. Planform studies were given a huge boost when aerial photography began in the 1920s and 1930s, and many investigators have found aerial photographs to be invaluable to the classification of meander form, study of meander processes, and documentation of changes through time.

Planform studies using maps and aerial photographs have yielded a number of empirical relationships for reach-scale meander geometry and scale. For example, Leopold and Wolman (14, 64) identified power law relationships between channel width (W), meander wavelength (λ), and bend radius (R_c):

$$\lambda = 7.32W^{1.1}$$

$$\lambda = 12.13W^{1.09}$$

$$\lambda = 4.7R_c^{0.98}$$

Richards (23) suggested that the exponent in the width-wavelength equation was not significantly different from unity and proposed a simplified version:

$$\lambda = 12.34W$$

Hickin (65) suggested a set of simple meander geometry equations broadly based on his results and those of earlier researchers (for example (66)) that could be used to predict meander response to changes in discharge:

$$\frac{\lambda}{W} \cong 10$$

$$\frac{\lambda}{R_c} \cong 4$$

$$\frac{R_c}{W} \cong 2$$

$$\lambda \cong 10Q^{0.5}$$

where:

λ	=	meander wavelength
W	=	bankfull width
R_c	=	radius of curvature
Q	=	bankfull discharge

Chang and Toebe (67, 68) investigated the effect of discharge on meander bend radius for two areas in the Wabash Basin with contrasting glacial histories and suggested:

$$\bar{R}_m = 24Q_{arc}^{1/2} \text{ (older) Illinoian glaciation}$$

$$\bar{R}_m = 197Q_{arc}^{1/3} \text{ (younger) Wisconsin glaciation}$$

Based on their results, Chang and Toebe concluded that the geological history of channel development, as well as the current flow regime, influences equilibrium meander form and they suggested that bend radius better represents meander geometry than wavelength. They also found that average discharge better represented river size than bankfull discharge.

Williams (69) compiled a wide range of data to derive a number of empirical relations defining meander planform geometry. Notable examples are:

$$L_m = 7.5W^{1.12}$$

$$\frac{\bar{R}_c}{W} = 2.43$$

where:

L_m	=	meander length
\bar{R}_c/W	=	geometric mean radius of curvature to width ratio for a reach

While indicative of a geometry that is common to meanders of very different scales and on rivers of different types, these equations have no basis in theory and are at best "morphological rules of thumb." It is no surprise then that the use of simple morphological relationships outside the area for which they were developed in river engineering and restoration schemes has been criticized by Rinaldi and Johnson (70).

Brice of the United States Geological Survey has been a notable proponent of the use of aerial photographs for meander planform analysis, amassing a large collection of historical aerial photographs for over 350 rivers in the continental United States (71). Brice used his collection (49, 72) to develop a classification of meander forms (73) and a method to assess channel stability based on aerial photographs (Figure 5).

Brice's classification correctly identifies that sinuous and braided behavior are not mutually exclusive and that rivers close to the meandering-braiding threshold may display elements of both patterns. In this respect, an examination of the Ovens and King Rivers in Australia is instructive (74). These rivers have multi-channel, anastomosing planforms in which individual anabranches adopt meandering planforms. However, the behavior of meanders differs from that in single-thread rivers in that increasing sinuosity leads to avulsion rather than meander migration. Schumm et al.'s (74) findings for sand-bed rivers in Australia were later replicated in North American, gravel-bed rivers. Gottesfeld and Johnson (75) used dendrochronology to date a history of channel change in the Morice River in Canada and found no pattern to the way channels migrated downstream in its "wandering" planform (wandering streams are in transition between braiding and meandering). Monitoring of the Tanana River in Alaska by Neill and Collins (76) showed how meanders in that multi-channel system migrate downstream in a way similar to meanders in single-thread rivers, but with rates and patterns affected by unpredictable internal shifting and switching of sub-channels and bars. Most recently, Jones and Harper (77) found that trends of sinuosity increase in the Rio Grande in Colorado were punctuated by abrupt reductions not due to cutoffs, but due to avulsions.

The existence of features in multi-channel systems that appear similar to meanders, but act differently, is a potential source of error when classifying meandering rivers for engineering analysis and prediction (78). This finding indicates that before classifying the degree or type of meandering, an initial screening is required to identify and exclude rivers that are actually multi-threaded (that is braided or anastomosing or wandering) even though they have meandering traits at certain scales or flow stages.

A further cautionary note on planform classification arises from the work of Alabyan and Chalor (79) which showed that different classifications may be valid for the same reach depending on the scale at which the channel is analyzed. Their review of extensive Russian literature recognized separate characteristic planforms at the scales of the valley bottom, flood channel, and low-water channel. Clearly, scale dependency must be borne in mind when classifying meander planforms, with the purpose of the exercise guiding the engineer to the appropriate classification scale for that particular application.

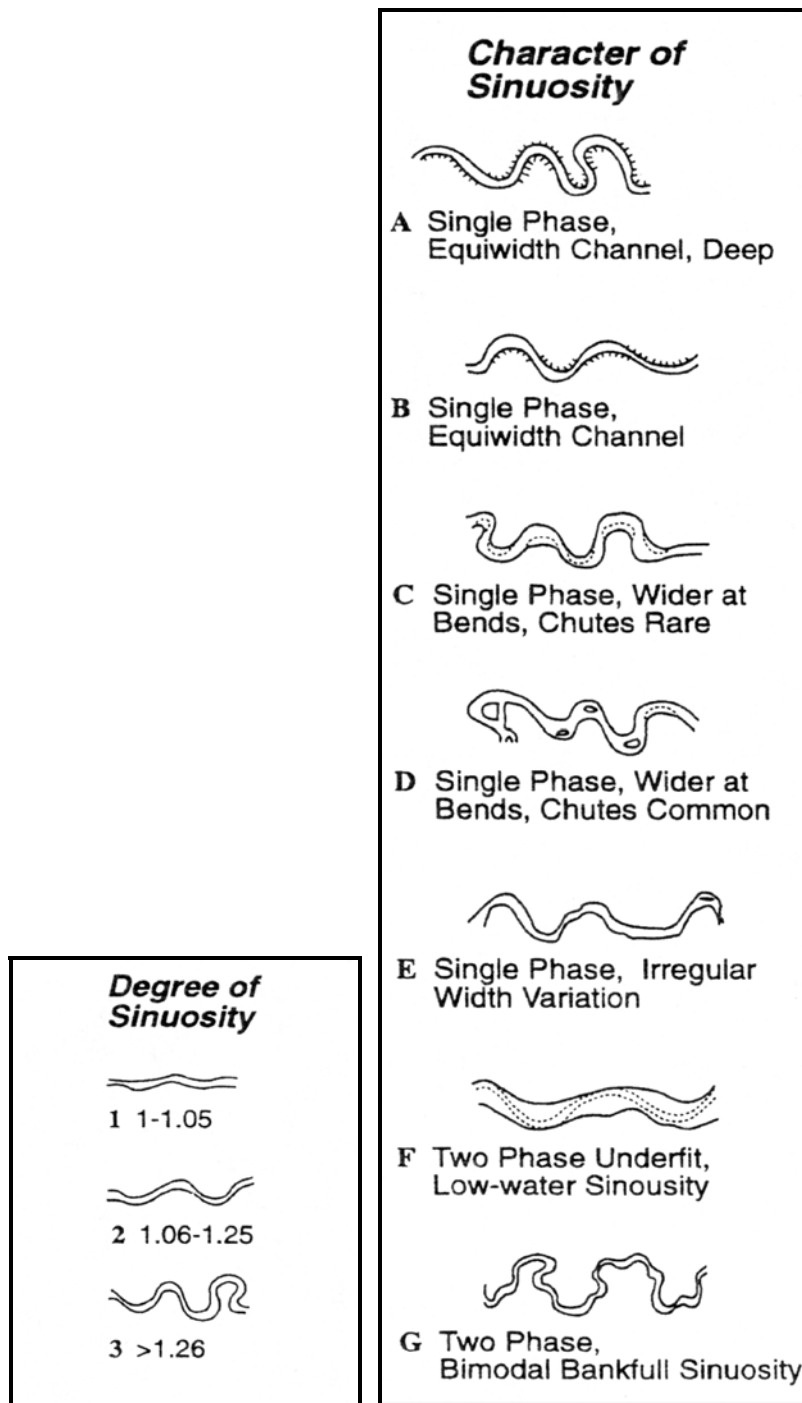

Figure 5. Brice classification of single-thread rivers based on the degree and character of sinuosity (adapted from (72)).

Brice applied his planform analysis and classification techniques to many practical problems: for example those associated with shifting of the Sacramento River (80) and channel response to artificial cutoffs (81). Brice's work is significant because it both founded and established the practical utility of contemporary and historical aerial photographs for meander classification, stability analysis, and migration prediction across the continental United States. Of particular relevance to the study of meander migration was Brice's discovery that the width of actively meandering channels varies systematically with planform position. Active meanders tend to be wider at bends than at crossings, while meandering channels that do not exhibit this trait – termed equiwidth by Brice – are static for long periods.

Lewin and Brindle (82) highlighted how a restricted floodplain width or narrow valley can constrict or even confine meanders. This topic was taken up by Richards (23) who used the case of the Afon Elan in Wales to demonstrate how the apparent meandering of this stream is actually caused by its deflection off valley wall bluffs on opposite sides of a relatively narrow floodplain. Richards' work is important in highlighting the existence of "passive meandering," which is displayed by sinuous channels in which meandering is either inherited from a former hydrologic regime or imposed by valley topography. In either case, bends look like those in an actively meandering stream, but differ in that they neither grow nor migrate. Stolum (83) explored the impact of finite valley width on active meandering, concluding that meander behavior is unaffected down to floodplain width 50 times the channel width, although an impact on the stable average sinuosity could be detected for valley widths less than 100 times the channel width.

Historical and Monitoring Studies of Meandering Rivers

Attempts to relate meander morphology to meander growth and shift, based on long-term monitoring and measurement, have contributed a great deal to our understanding of meandering. A good example is work conducted by Braga and Gervasoni (84), who used a particularly long period of record based on historical maps to chronicle the evolution of the Po River in Italy between 1230 and 1980. Figure 6 shows the planform features and geomorphic surfaces associated with meander morphology and migration identified through geomorphic measurement and monitoring in the field.

Historical and long-term field studies have revealed how meanders evolve, even if they only hint at why. It has long been recognized that point bar construction and bank erosion are the principal process drivers responsible for lateral channel migration and meander evolution (14, 29, 31, 85, 86, 87, 88, 89, 90, 91, 92, 93). The broad pattern of scour along the outer bank and deposition along the inner bank can be explained qualitatively by the flow patterns and the related distributions of velocity, sediment transport capacity, and sediment sorting at bends (see discussion of Flow Patterns). Despite this, attempts to quantify and predict the association between the dynamics of water and sediment, the morphology of the bend, and interaction between the hydraulic, sedimentary, and morphological adjustments responsible for bend evolution remain imperfect (see discussion of Numerical Modeling). Hooke (32, 94, 95) presents a good series of reviews of channel changes observed in monitoring studies during the twentieth century.

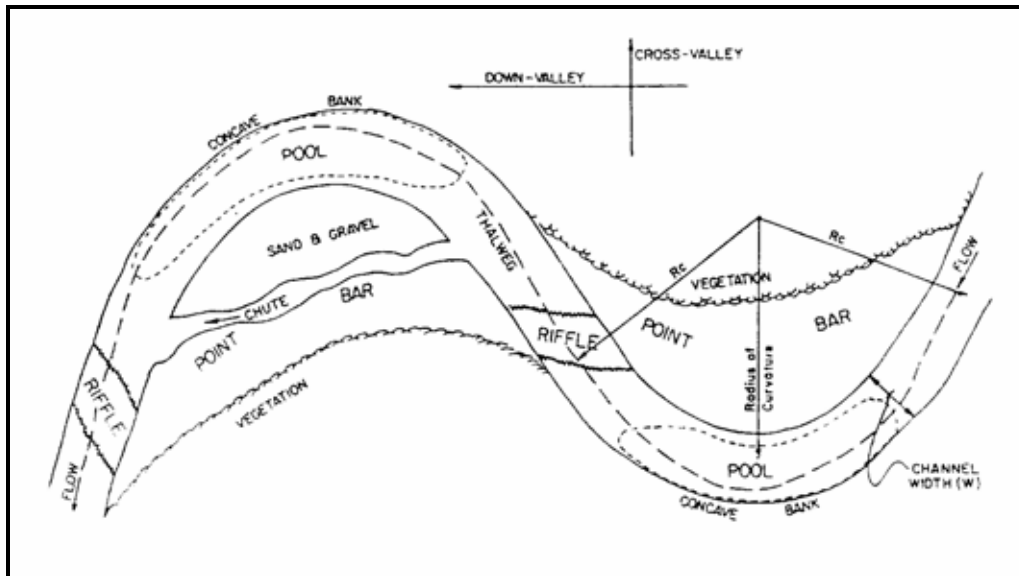

Figure 6. Schematic diagram showing in planform features and geomorphic surfaces associated with meander bends.

Hickin and Nanson conducted important studies of bend form and evolution based on historical analysis of the Beatton River in Canada (88, 90, 96, 97, 98, 99). Initially, the history of meander evolution was inferred from scroll bars left on the floodplain. Scroll bars are crescent-shaped ridges observed inside migrating bends and taken to represent the radius of the inner bank at the time the sediments forming the ridge were deposited.

Hickin (88) noted that migrating bends maintained a R_C/W value of about 2 and that, while the channel seemed to display dynamic stability over long periods, natural cutoffs induced channel changes triggered by renewed meander development in bends adjacent to the cut off bend. Hickin and Nanson (98) carried the analysis further, concluding that the maximum rate of bend migration occurred when R_C/W was about 3. It should be noted that the referenced radius was based on scroll bar curvature and pertains to the inner bank radius rather than the more common convention of using the centerline radius to represent the bend curvature.

In a later paper, Hicken (96) observed that migration was discontinuous, with individual loops migrating and depositing sediment during a number of distinct migration phases. Hickin found that each phase has an initiation stage, growth period, and abrupt termination stage. Termination was associated with a R_C/W of about 2.

Nanson (99) broadened the scope of studies of the Beatton River to include consideration of neotectonics (i.e., recent and ongoing surface deformation associated with tectonic processes). He concluded that the valley of the river is tilted to the east and that meanders grew preferentially down-tilt. However, the extended down-tilt bends cut off more frequently, so that the channel was positioned to the western side of the valley.

Nanson and Hickin (90) and Hickin and Nanson (100) built on the findings from the Beatton River, adding data from other rivers to produce generalized descriptions of bend migration for engineering applications. The tools developed indicate that the maximum rate of bend migration (made non-dimensional by dividing it by the width) can be expressed as a function of bend curvature, represented by R_C/W .

- Newly initiated bends have a long radius and grow slowly (initiation stage, $R_C/W > 10$).
- As bends develop and tighten, the erosion rate increases rapidly (growth period, $3 < R_C/W < 10$).
- Bends then maintained their shape, while migrating rapidly (migration phase, $2 < R_C/W < 3$).
- If the bend becomes overly tight the erosion rate falls abruptly and the bend is cut off (termination phase, $R_C/W < 2$).

Many subsequent studies have reinforced Hickin and Nanson's basic description of the stages of bend development, while also demonstrating that there is wide variation in the relative rates of erosion for a given degree of bend curvature (93, 95, 101, 102, 103, 104, 105, 106, 107). Figure 7 presents a summary compilation of data from several sources (including Hickin and Nanson). It should be noted that the curves shown in Figure 7 represent upper bounds to data clouds rather than best-fit lines. In fact, there is great variability in the rate of erosion for a given R_C/W , especially at values around 2 to 3.

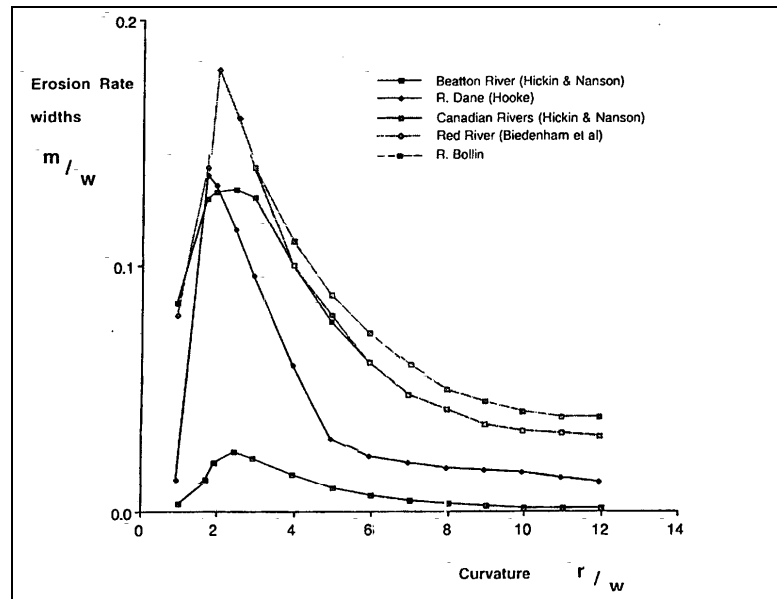

Figure 7. Erosion rate as a function of bend curvature for data from Hickin and Nanson and other authors (adapted from (32)).

Some of the variability may be explained by boundary conditions, such as the erodibility or mass stability of the outer bank of the bend. For example, Biedenharn et al. (104) showed that bends on the Red River in Arkansas that encountered clay plug, backswamp or Pleistocene materials migrated much slower than those eroding banks formed in meander belt sediments.

A further source of variability was revealed by observations of channel evolution on the Lower Mississippi River by Larsen and Shen (108). They found that the sinuosity of 55 bends increased progressively over long periods of time. When the sinuosity became large, the bend was cut off, with the life span of a bend being of the order of 600 years. However, the occurrence of a cutoff not only reduced the sinuosity of the cut off bend, it also influenced adjacent bends upstream and downstream. This phenomenon was also observed by Hooke (109) following both neck and chute cutoffs on the meandering River Bollin in England. She showed that in a dynamically meandering stream the effect of a cutoff in one bend is absorbed through local morphological adjustments in adjacent bends. These studies demonstrate that the rate of erosion at a given bend is determined not only by the geometry of that bend, but also the evolution of the bends immediately upstream and downstream (110).

Clearly, while the sequence of erosion phases proposed by Hickin and Nanson may be discerned in Figure 7, further variables would have to be added to produce a satisfactory predictive tool with general applicability.

A further point that arises from review of historical studies of planform change and shifting is that by no means do all meandering rivers display the degree of lateral activity suggested by Figure 7. For example, Biedenharn et al. (111) found that despite its sinuous course, the planform position of the low gradient Ouchita River in Arkansas and Louisiana has remained stable for 160 years. Similarly, Swanson (112) found that a meander loop in the higher energy Tazlina River in Alaska changed very slowly. The existence of sinuous rivers with stable, nearly static planforms indicates that it cannot be assumed that meanders will grow or migrate significantly on the basis of a single site visit or air photograph. Repeat measurements, long-term monitoring, or comparison of historical aerial photographs are essential to differentiating dynamic from passive or stable meanders.

Factors Affecting Rates Of Meander Change

As a bend evolves in an initially straight channel, the radius of bend curvature decreases and the rate of migration tends to increase because increased curvature strengthens secondary currents and helical flow so that:

- Pool zone is constricted laterally against the outer bank (78)
- Point bar expands (23, 24, 78)
- Intensity of fluvial attack of the outer bank increases (7)
- Stability of the outer bank with respect to mass failure decreases (22)
- Bank retreats and debris is removed (113, 114)
- Meander migrates through scour along the outer bank, deposition along the inner bank, and renewed constriction (115)

Consequently, over the medium- to long-term, the rate of meander bend growth and migration takes place through complex interactions between flow and morphology, depending on multiple factors. Compiling the findings of several studies together (91, 113, 36), important factors influencing meander migration rate include:

- Discharge (magnitude and frequency of channel forming flows)
- Bed material mobility (ability of curved flow to produce bend scour)
- Supply of sediment (availability of sediment to fuel point bar growth)

- Bank erodibility (ability of banks to withstand fluvial shear stress)
- Bank geotechnics (bank stability with respect to slip failure)
- Bank vegetation (through affects on flow erosivity, bank erodibility and bank stability)
- Basal clean out (removal of bank failure debris from base of eroding bank)
- Human interventions (impacts of river regulation, re-alignment and bank stabilization)

Discharge

The importance of discharge, and particularly high, formative events, has been established through a large number of flume and field studies. Ackers and Charlton (116) used a large sand flume to show that over time the plan geometry of a meandering channel adjusts to the dominant or bankfull discharge. Field studies by Hughes (117) supported this finding in that major meander adjustments were related to floods with a recurrence interval of 1.5 years (usually taken to represent bankfull discharge).

Schumm (118) chronicled river changes resulting from climate induced alterations to runoff in the Murrumbidgee River in Australia, and Daniel (119) related the movement of meanders in Indiana streams to the duration of above-average discharge events. Hooke (120) found most bank erosion to be associated with peak flows. Laczay (121) showed that over a 35-year period migration rates of Hungarian rivers were positively related to periods of increased runoff associated with hydrological variability. Hagerty et al. (122) studied bank erosion along the Ohio River, relating the rate of erosion to discharge, although Odgaard (44) reported similar rates of bank erosion on two different rivers in Iowa. The East Nishnabotna River has a natural regime while the Des Moines River is regulated by Red Rock Reservoir. Despite differences in discharge magnitude and regime, both undergo cutbank erosion in bends at a rate of 10 to 13 feet per year (2 to 4 meters per year).

Mobility of Bed Material

Nagabhushanaiah (123) suggested that the necessary condition for the origin and formation of meanders in an alluvial stream is the erosion of bed material and deposition of the eroded material downstream. The ability of the river to entrain and transport bed material depends on the relationship between specific stream power and bed material size. Van der Berg (124) compiled a large data set based on the results of previous studies to relate channel planform pattern to stream power and bed grain size. Lewin (125) reported a good relationship between unit stream power at bankfull discharge and channel shifting rate for three rivers in Wales. Often, sediment mobility is highest in the middle reaches of the drainage basin – corresponding to the "transport zone" in the fluvial system (126). For example, in studies of the Rivers Bollin and Dane, Hooke (109) found that meander migration was indeed greatest and cutoffs occurred most frequently in the middle reaches of these gravel-bed rivers.

Bed material grain mobility does not vary only through the system, however, and wide fluctuations may occur over relatively short distances, especially due to local variations in channel or valley slope. Nagabhushanaiah (123), Martinson (127), and Hooke (128) all found that the most active meanders were located in the steepest reaches of their study rivers. Schumm et al. (129) investigated local slope variations due to valley floor warping by neotectonic activity. They found clear evidence of morphological deformation caused by neotectonics. The sensitivity of morphology to local slope variability may explain why Hooke (109) reports that there is no simple relationship between reach-averaged stream power and migration rate.

The scour resistance of material generally increases with grain size, but for very fine sediment erosion resistance and scour depth may be limited by cohesion. Rhoads and Miller (130) attributed the lack of a morphological response to high flows on a stretch of the low-energy Des Plaines River in Illinois to the presence of fine bed material.

Nanson and Hickin (91) used statistical analysis of bank erosion and channel migration in western Canada to show that 70 percent of the variability in migration rates of 18 meandering rivers could be explained by variability in discharge and bed sediment size. On this basis, it appears that while discharge and bed material size are the predominant controls on migration rate, other variables may also be significant.

Sediment Supply

In a flume study, Ackers and Charlton (131) demonstrated that an increase in sediment load could both trigger the initiation of meanders in a formerly straight channel, and drive an increase in the sinuosity of a meandering channel. Neill (132) likewise noted that an increase in bank erosion rate was associated with elevated levels of bed load. A long-term study of the Oconee River in Georgia by Brook and Luft (133) provides a useful case study of the effects of changes in sediment supply on meander migration. During the 19th and early 20th centuries, land use changes that made the watershed more erodible coupled with higher than usual peak and annual discharges raised sediment concentrations in the river. The channel responded through accelerated meander migration that produced an increase in sinuosity and decreases in wavelength and bend radius. After about 1910, improved soil conservation and runoff management produced decreased sediment concentrations and peak flows. The channel responded by decreasing its sinuosity while increasing meander wavelength and bend radius.

This sequence of process-response is by no means unique to the Oconee. For example, Burke (134) chronicles a similar record of meander change triggered by natural processes and human activities on the Kansas River over a 125-year period. Historical records of bend movement over a period of 100 years compiled by Lewin (54) illustrated the influence of sediment transport pattern on bend migration rate, with the spatial distribution of rapid shifting being associated with changes in the local sediment transport pathways.

Chang (135) supplied a theoretical explanation for the sensitivity of meandering to sediment supply. He demonstrated how the bedload/discharge ratio for an alluvial channel of constant slope and sediment size varies in response to changing discharge. Following a decrease in discharge, the sediment load supplied from upstream decreases proportionately more than is required to maintain a constant slope. The channel responds by increasing its sinuosity through enhanced meandering, which reduces the slope in line with the reduced sediment supply. Yen and Ho (136) provide further evidence of the importance of sediment movement on bend evolution, especially through its effect on bedforms.

Erodibility of Bank Materials

The mobility of meanders is affected by the erosion resistance of the material forming the retreating bankline. Rhoads and Miller (130) studied the morphological impacts of sequential flows, including a 100-year flood and several bankfull events, on a 4.5 mile (7.2 km) reach of the

Des Plaines River in Illinois. The response of the river was minor and Rhoads and Miller attributed this in part to the high erosion resistance of the cohesive banks.

Hasegawa (137) developed a bank erosion coefficient based solely on the bank soil properties. He found that the value of the effective bank erosion coefficient was similar for different rivers, suggesting that it possesses characteristics that are sufficiently universal to justify its use as a basis for predicting bank erosion rates at meander bends.

However, Hooke (120) pointed out that erodibility is not a conservative bank property. She discovered that rates of erosion for a given peak flow were much higher if antecedent precipitation had weakened the banks by raising soil moisture levels. Similarly, Lawler (138) discovered that frost action greatly weakens exposed bank soils, significantly reducing their ability to resist subsequent fluvial shearing.

In any case, in a later paper Hasegawa distinguishes between bank erosion equations and meander migration equations, concluding that with regard to erodibility coefficients, it is "too early to consider the relations being universal" (139). Thein (140) provides a useful review of bank erosion studies and development of bank erosion models.

Bank Geotechnics

Chitale (141) attributed progressive recession of the bankline in river meanders to instability of the side slopes. He used a simple slope stability equation for planar slides to relate the limiting height for a vertical river cliff to the geotechnical properties of the bank material:

$$h = \frac{4c \cot \phi}{\gamma \quad 2}$$

where:

h	=	limiting vertical height of bank
c	=	bank material cohesion
γ	=	specific weight of bank material
ϕ	=	friction angle of bank material

Thorne et al. (142) first recognized that limiting bank height with respect to mass stability could represent a geomorphic threshold capable of influencing the evolution and eventual equilibrium morphology of unstable alluvial streams. Thorne and Osman (113, 114) applied this principle to meandering channels, using a bank stability model developed by Osman and Thorne (143). They demonstrated theoretically the influence of the bank's geotechnical properties on lateral shifting at meander bends. In weakly cohesive banks, the limiting bank height with respect to mass stability affects the equilibrium scour depth, cross-profile, and migration rate. Subsequent empirical work by Thorne (4) on the Red River in Arkansas provided field validation of the conceptual hypothesis that bend geometry and migration are influenced by bank geotechnics.

Riparian Vegetation and Land-Use

The influence of bank vegetation on meander migration has been recognized since the early 1980s. Hickin (144) suggested that vegetation would directly affect fluvial processes and channel dynamics through five mechanisms:

- Resistance to flow
- Bank material strength
- Providing a nucleus for bar sedimentation
- Concave bank bench deposition
- Construction and breaching of log jams

Gray and MacDonald (145) addressed the first and second effects identified by Hickin. They noted that vegetation increases the effective roughness height for the bank and produces a three-layer flow field next to the bank consisting of:

- A viscous sub-layer adjacent to the soil-water interface
- A turbulent zone with wake effects extending up to the top of the vegetation stems
- A zone outside the vegetation that is free of wake effects

Measurements made in the turbulent zone during a significant flood indicated that reduction of velocities and damping of turbulence within the wake zone rendered the near-bank flow non-erosive. They further noted that plant roots reinforced the soil, significantly increasing its shear strength and reducing erosion rates – an effect first noted by Smith (146). The wider influence of root reinforcement by riparian vegetation on spatial patterns of channel instability at the reach-scale was demonstrated in a monitoring study of Little Piney Creek in Missouri by Jacobson and Pugh (147).

However, Peterson (148) pointed out that to be effective in reducing flow erosivity and enhancing soil erosion resistance, vegetation must extend to the interface of the water surface and the bank. Similarly, Thorne (22) noted that root reinforcement is only effective if roots cross the most critical potential failure plane, which may be deep within the bank. Hence, bank height relative to the position and rooting depth is important, and the presence of vegetation at the outer bank alone does not guarantee a reduced migration rate.

Land-use change that alters the vegetation on and behind the eroding bankline can have a spectacular impact on the rate of meander migration. Migration rates seem to be particularly sensitive to removal of the riparian forest. For example, Beck et al. (149) noted that lateral channel movement along the Genessee River in New York was 130 percent faster through farmland than in forested reaches. Beeson and Doyle's (150) work indicates even stronger effects in that bends without riparian vegetation were nearly five times more likely to undergo detectable erosion during a flood event, and bank erosion was thirty times more prevalent on non-vegetated banks than vegetated ones. More recently, Burckhardt and Todd (151) found that average migration rates for bends with unforested concave banks along streams in Missouri were three times that for bends with forested banks.

The results of Murgatroyd and Ternan (152) are often quoted as challenging the generality that land-use change involving deforestation accelerates meander migration. They found that afforestation *accelerated* bank erosion. Careful reading of Murgatroyd and Ternan's paper indicates that in their study accelerated bank erosion occurred because afforestation led to increased channel width, reduced sinuosity, and formation of mid-channel bars, thereby producing a braided pattern. Hence, afforestation triggered planform metamorphosis rather than acceleration of meander migration, and the general finding that bends migrate faster through areas cleared of riparian forest still holds.

Basal Cleanout

Sustained retreat of an alluvial stream bank can only occur if near-bank flow in the channel is able to remove the debris produced by bank erosion and failure (22). Where debris removal does not keep pace with retreat of the bank top, a wedge or berm of bank-derived sediment accumulates, buttressing the bank and protecting intact material at the toe from fluvial scouring. Hence, in the medium- and long-term, rates of bank retreat and meander migration depend on the sediment transport capacity of flows near the eroding bank. This was recognized in the early 1980s, when Hickin and Nanson (100) proposed that a constant representing bank erosion resistance was largely a function of the basal sediment size. Jones (153) went further, concluding that the rate of bank retreat is controlled by the rate of basal removal of erosion products.

Human Intervention

Brice (81) conducted stability assessments of 100 meandering channels affected by engineering realignments and relocations. The typical channel response to a bend cutoff was widening of the new channel and acceleration in the growth rate of adjacent bends. Brice suggested that, as a general rule, the length of channel affected by scour upstream of a cutoff is in the range 10 to 20 times the width. Work on natural cutoffs by Hooke (109) also indicated that these adjustments are completed quickly, with rapid response in 2 to 3 years following a cutoff, and completion of even major adjustments within 6 to 12 years.

Bradley and Smith (154) showed how artificial diversion of flow from the St Mary River into the Milk River in 1951 increased the mean discharge downstream and resulted in increased mean meander migration rate from 4.4 ft/year to 7.2 ft/year (1.35 m/year to 2.2 m/year). Conversely, closure of a dam on the Milk River in 1952 significantly reduced peak flows in the reach downstream of the dam resulting in a decrease in migration rate from 5.7 ft/year to 1.5 ft/year (1.75 m/year to 0.45 m/year). Decreases in meander migration rate following dam closure were also observed in a general study of downstream effects of dams by Williams and Wolman (155) and more specifically on the Bighorn River in Wyoming (156), the Brazos River in Texas (157), and the Marias River in Montana (158). However, Whitesell et al. (56) concluded that closure of Denison Dam on the Red River Oklahoma had no significant impact on river planform. A good review of the impact of dams on rivers and meander migration is provided by Friedman et al. (159).

Friedkin (11) conducted laboratory experiments to demonstrate the effect of bank revetments on meander geometry, showing how attempts to stabilize the outer bank in a meander led to deeper scour that tended to undermine the revetment. Thorne (4) noted a similar response in the Red River in Arkansas.

Overview

A considerable body of literature was reviewed to illustrate how a wide range of controls on meander growth and shift will complicate any attempt to generalize behavior from one meander to another. These are summarized In Table 1 and Figure 8.

Table 1. Controls on Meander Morphology and Variability of Change.	
Geology	
1	Faults - can change valley slope
2	Uplift - can change valley slope
3	Subsidence - can change valley slope
4	Bedrock outcrops in bed and/or banks - can prevent degradation or meander shift
Alluvium	
5	Clay plugs - provide local hard points that affect meander shift and growth
6	Fine-grained sediments form floodplain (backswamp deposits - inhibit meander migration)
7	Tributary contribution – different type of sediment and/or increased sediment load.
Pattern Change	
8	Upstream cutoff - steepens channel, increases sediment delivery downstream, can cause additional cutoffs
9	Downstream cutoff – causes upstream degradation
10	Flow direction change – shifts focus of maximum erosion downstream
Human	
11	Channelization (modification of reach)
12	Revetments and bank protection
13	Cutoffs (Modification of a bend)
14	Dams and diversions, land use
Vegetation	
15	Type and density of vegetation

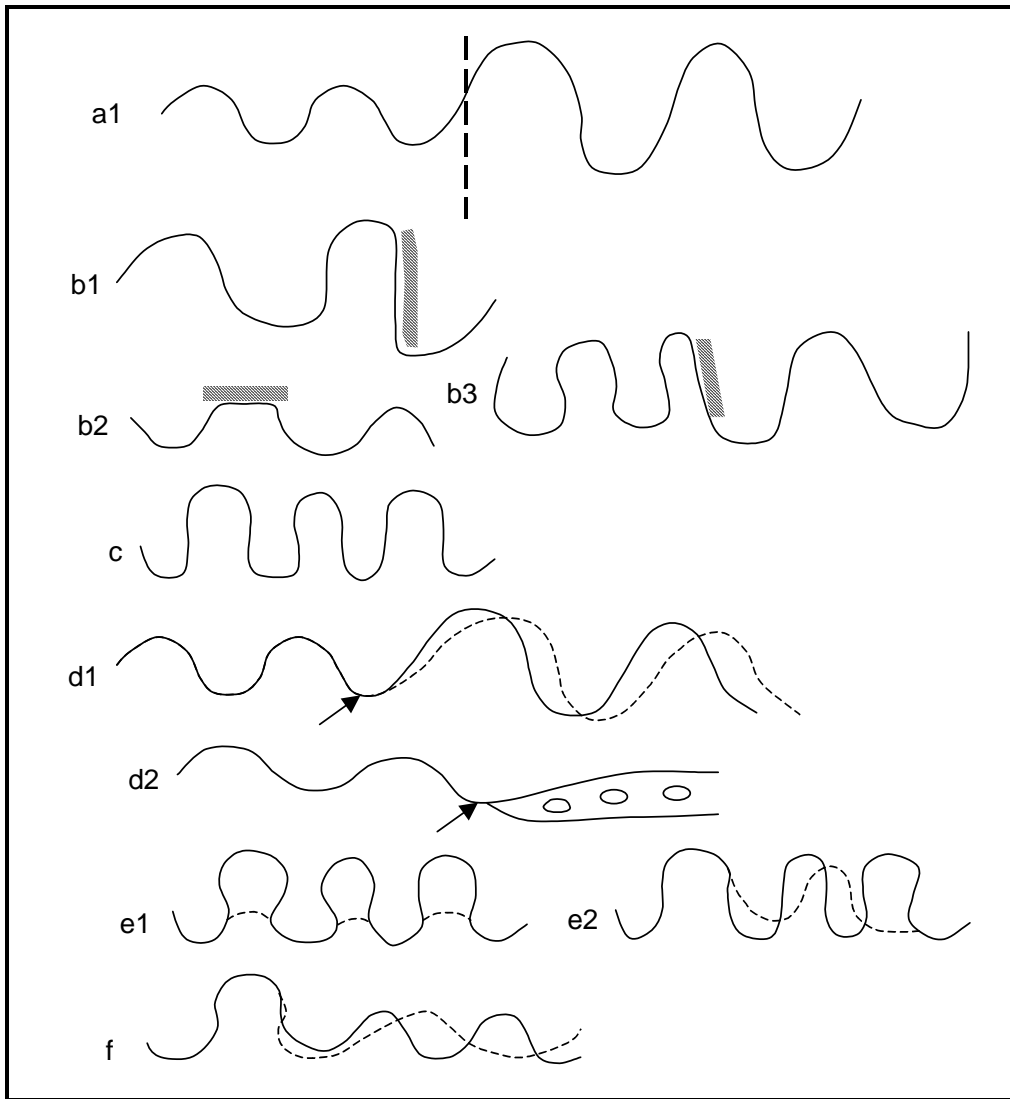

- a A fault or uplift steepens valley downstream of fault or axis of uplift (dashed line).
- b Meanders deformed by encountering bedrock or resistant alluvium. Hatching indicates resistant material.
- c Uniform relatively stable, high amplitude meander in backswamp alluvium of Mississippi valley.
- d Change of meander pattern as result of sediment influx from tributary (arrow). Depending on type of sediment load, sinuosity may increase or decrease or river may braid. Dashed lines show expected change.
- e Effects of cutoff or change of flow orientation on downstream river pattern. Dashed lines show expected change.
- f Change of flow direction of upstream meander affects shape of downstream meander. Dashed lines show expected change.

Figure 8. Controls on river patterns.

The effects of most of these variables are shown diagrammatically in Figure 8. Each example is based upon observations made on rivers, and each numbered example of Table 1 is considered as follows:

- 1 A fault, which crosses the river and steepens it locally, will cause a change of sinuosity (Figure 8-a1) and increase the rate of meander migration.
- 2 Deformation of a valley floor by uplift will also create two reaches of different morphology and behavior. Upstream of the axis of uplift the channel will be less sinuous and less active than the steeper reach downstream of the axis (Figure 8-a1).
- 3 Subsidence will reverse the sequence of Figure 8-a1 with the steepest reach located upstream of the axis of uplift.
- 4, 5 When an alluvial meander encounters resistant sediments or bedrock, the downstream limb of the meander will be fixed in position and the upstream limb will continue to migrate, thereby deforming the meander (Figure 8-b1). A meander increasing in amplitude will develop a flat top, when it encounters resistant material (Figure 8-b2). Finally, a sequence of meanders may be deformed as they shift down valley toward resistant material (Figure 8-b3).
- 6 A river entering a region of resistant floodplain sediments such as backswamp deposits in the Mississippi Valley will develop characteristic stable bends of relatively high amplitude (Figure 8-c). The farthest downstream bends of the Mississippi River are of this type and they are very different from those upstream. The rate of change is much higher upstream.
- 7 A tributary that introduces a large sediment load into the channel can have a major impact. The Arkansas River has introduced a large sediment load of sand into the Mississippi River. This has steepened the gradient downstream of the confluence, which increases sinuosity and the rate of meander growth and shift (Figure 8-d1). Introduction of a high sand load can also cause braiding (Figure 8-d2).
- 8 Meanders can be affected by bend behavior both upstream and downstream. A cutoff upstream can cause incision that increases sediment delivery downstream, which in turn can trigger additional cutoffs or increase meander growth and the migration rate (Figure 8-e1).
- 9 Downstream cutoffs can cause incision upstream, increased bank erosion, and perhaps increased meander migration (Figure 8-e2).
- 10 Even a change in shape of a meander can cause a change of flow direction, which affects the downstream pattern (Figure 8-f).

- 11,12,13 Human activities both upstream and downstream can significantly impact a river. Therefore, the highway engineer must consider future work on the river and changes of land use when evaluating meander impacts.
- 14 Hydrologic changes will affect rates of meander growth and shift. Dam construction and reduced peak discharge reduces the rate of meander migration.
- 15 Riparian vegetation usually reduces bank erosion and the rate of meander shift, but if the vegetation or its roots are not actually on the bank, they may have no effect (see (147)).

Styles of Meander Change

The location of maximum bank erosion within a bend changes as the bend evolves and so too does the primary direction of meander movement. The complexity of meander growth, migration and distortion has been described by a number of authors and is codified in a number of styles of change (Figure 9).

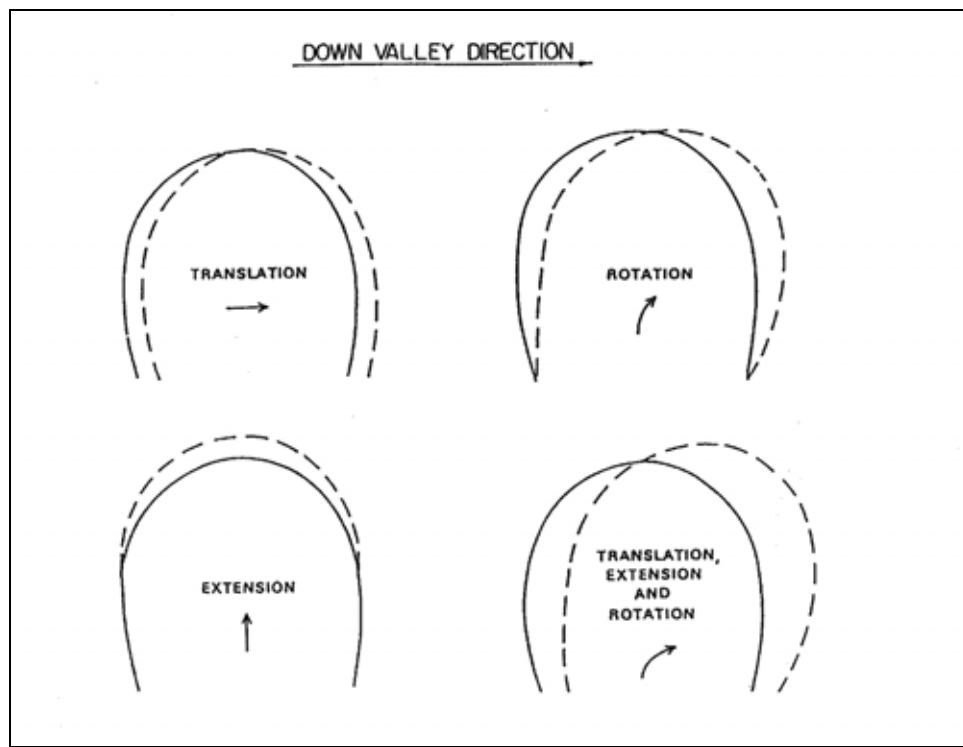

Figure 9. Styles of change displayed by meander bends (adapted from (24)).

Initially, bends tend to grow in a direction that is transverse to the valley axis (31), and this has been referred to as extension (24, 80). This pattern of development occurs because maximum erosion is located close to the bend apex (109).

Eventually, because of flow separation at the inner bank downstream end of the point bar, which effectively establishes a minimum resistance to flow, meander activity switches from primarily driving growth, to promoting downstream migration, which is referred to as translation (24, 29, 31). Under these circumstances, the zone of maximum bank erosion is located downstream of the bend apex (109). However, meander bend activity is by no means limited to growth and migration; bends also display changes described in terms of rotation and combinations of extension, translation, and rotation (Figure 9). Hooke (160) synthesized the results of several previous studies to suggest the following styles of meander change:

<u>Simple</u>	<u>Combined</u>
Extension	Extension and Rotation
Translation	Rotation and Extension
Rotation	Rotation and Translation
Enlargement	
Complex	

She pointed out that stable reaches, unstable reaches, and reaches with changing channel pattern within a given stream may co-exist, so that there is no single style of meander change that can be applied to describe planform change in the system.

As meanders grow by extension, the channel length increases. There is evidence from both conceptual and observational studies that as the channel spacing between crossings increases, a point is reached where flow through very long bends breaks down to produce an intermediate riffle and two minimum curvature points (12, 161). Parker (162) echoed these findings, describing how high amplitude bends tend to double back on themselves and develop intense skewing. As a result, they exhibit slower rates of downstream migration and become vulnerable to neck cutoff by a more rapidly migrating bend upstream. Whiting and Dietrich (163, 164) re-examined large amplitude meander evolution in long bends in detail, illustrating the process and mechanisms responsible for generating complex growth behavior. They found that multiple pools spaced at about 3 to 4 channel widths developed along the outer bank, separated by distinct bars at the inner bank. These bed features cause localized bank erosion that produces bend asymmetry and compound behavior and "double heading."

Meander bends eventually cut off when the curvature becomes very tight. This may occur due to stalling of the flow and generation of a zone of flow separation at the outer bank, or as the result of the arrest of the down valley limb of the bend by more erosion-resistant material.

Cutoffs occur as a result of chute development (80, 93, 101) or neck closure (58, 126). A chute cutoff is a manifestation of reduced hydraulic slope which causes reduction in sediment-transport capacity of the flows within the upstream portion of the bend and leads to sediment deposition within the channel and reduced hydraulic capacity of the channel (8, 78, 93). Reduced hydraulic capacity in the upstream portion of the bend increases the frequency of flows over the point bar which leads to chute development and eventually bend cutoff (78, 93). A neck cutoff is a manifestation of late-stage bend evolution in a tortuous meandering system with erosion resistant bank materials or meander distortion by plugs or bands of resistant material.

Conceptual and Empirical Models of Meander Evolution

Conceptual Models of Meander Migration

The evolution of a bend through time should be predictable, bearing in mind that channel migration has been shown to be a discontinuous process that is highly dependent on the occurrence of morphogenetically significant hydrological events (71, 88, 90, 91, 93). Numerous geomorphological studies have taken data from different locations and used the data to infer landform development through time (129, 165, 166, 167, 168). Harvey (93), using this location-for-time substitution technique, developed a seven-stage model of bendway evolution for the Sacramento River that related bend shape (reducing radius of curvature through time) to both migration rates (bank erosion) and cutoffs. Hooke (109) has produced a similar model of meander evolution.

Bagnold (29), Leeder and Bridge (31), Nanson and Hickin (90, 91), and Harvey (93) have demonstrated that lateral migration rates of meandering rivers can be correlated with the radius of curvature of bends. Migration rates (MR/W) are highest when the radius of curvature to channel width ratio (R_C/W) is about 2.5, and they are lower when R_C/W is both higher and lower because of the lack of flow convergence and energy loss, respectively. Considerable scatter is apparent in the data, but based on the Beatton River data, Nanson and Hickin (90) showed that at a R_C/W ratio of 2.5, the migration rate, expressed as channel widths per year was maximized (about 0.03 channel widths per year), and that lower values of channel migration were correlated with $2 < R_C/W > 4$. Using multi-variate statistics on a data set derived from 18 rivers in Canada, Nanson and Hickin (91) demonstrated that 70 percent of the volume of erosion of the concave bank could be explained by the size of the river, and the grain size of the sediment at the base of the bank.

Keady and Priest (169) observed the downstream migration rate of "free" meanders in alluvial rivers to produce:

$$\frac{V}{\sqrt{gA}} = f(S)$$

where:

V	=	migration rate (ft/year)
g	=	gravity (ft/s ²)
A	=	meander amplitude (ft)
S	=	free surface slope
f	=	"function of"

They showed that migration rate peaked when $S \times 104 = 1.5$.

Because meander migration is a discontinuous process dependent on the occurrence of morphogenetically significant flood flows, Harvey (93) evaluated both short- and long-term meander migration rates on the Sacramento River. Short-term rates were calculated for the

period between 1981 and 1986 in which two significant floods occurred (1983, 1986). For radius of curvature (R_c) values between 1,250 and 2,750 feet (381 and 838 m) (R_c/W values of 2.5 to 5.5), the migration rates (MR) varied from 32 to 122 feet/year (9.8 to 37.2 m/yr). A least squares regression of the data is:

$$MR = 175.8 - 0.049R_c \quad (R^2 = 0.69)$$

The progressive development of a meander bend can occur to the point where it cuts off. Recent (within the period of record between 1896 and 1986) and historic cutoffs on the floodplain of the Sacramento River were investigated to evaluate whether cutoffs could be predicted (93). A dimensionless cutoff index, which is defined as the ratio of the Radius of Curvature to the migration distance (R_c/MD), was developed to predict cutoff occurrence. For the coarse-grained meanderbelt section of the Sacramento River, the dimensionless cutoff index is:

$$1.7 < R_c/MD < 3.7$$

For the fine-grained meanderbelt section, where the floodplain sediments are more cohesive, the cutoff index is:

$$2.5 < R_c/MD < 4.3$$

Hooke (120) related erosion rate to watershed area (a surrogate for discharge or channel width) and showed that the resulting regression relationship could explain 53 percent of the variation in mean erosion rate and 39 percent of the variation in maximum erosion rate. The equations obtained were:

$$Y = 8.67 + 0.114 A$$

$$Y_{\max} = 2.45 A^{0.45}$$

where:

Y	=	mean erosion rate (m/year)
Y_{\max}	=	maximum erosion rate (m/year)
A	=	watershed area (km^2)

Martin et al. (170) studied the migration of bends on the Lower Mississippi River to classify bends into six categories based on their style of evolution. The categories were:

- Downstream limb migration
- Downstream limb rotation
- Mainly upstream limb migration
- Upstream limb rotation
- Pure translation
- Pure expansion

Over 60 percent of future meander migrations could have been predicted from the characteristics of each individual bend in the initial channel pattern. Martin et al. (170) found that the most stable meander bend radius to width ratios were in the range 1.0 to 2.8. The close association identified between bend characteristics and future evolution suggests that a predictive approach based on classifying bend types and using this to predict the style of change in the next few years has promise. However, classifying bends in this way requires skill and consistency on the part of the observer and it is by no means certain that relationships between morphological classes and styles of development are transferable between streams.

Numerical Models of Meander Migration

Nagabhushanaiah (123) was one of the first researchers to develop an equation for meander expansion. He concluded that the origin and development of meanders in an alluvial channel depend on the erosion of bed material and its subsequent deposition downstream. He then used experimental results to calibrate a theoretically-based equation:

$$\frac{M_w}{d_s} = 0.76 \left[\frac{(QS^2 - Q_c S^2)t}{d_s^3} \right]^{0.5}$$

where:

M_w	=	meander width
d_s	=	mean diameter of bed material
Q	=	discharge
S	=	longitudinal bed slope
Q_c	=	critical discharge for initiation of bed material movement
t	=	time

This equation, like so many other empirical approaches, deals with some but not all of the processes involved in meander growth. For example, no account is taken of the relative erodibility of bank versus bed sediments or the manner in which bend growth alters as the ratio of bend radius to width decreases through time.

Nakagawa (171) made the ratio of total bank shear force to total bed shear force (both per unit length downstream) the basis for his equation to predict meander initiation. He concluded that a necessary (but not in itself sufficient) condition for stream meandering was:

$$\frac{\tau_s p_s}{\tau_b p_b} < \alpha$$

where:

α	=	0.2
τ_s	=	average bank shear stress
τ_b	=	average bed stress
p_s	=	average bank wetted perimeter of half a channel
p_b	=	average bed wetted perimeter of a half channel

Chang (172) produced a numerical water and sediment routing model (Fluvial-11) capable of predicting time and spatial variations in the water surface profile, cross-sectional profile, and other variables. In essence, this model could be used to model channel changes in meandering rivers, although it uses very simple representations of bank slopes (planar) and bank erodibility that would limit its applicability to streams with banks formed in uniform, non-cohesive materials. Unfortunately, very few rivers have banks with planar slopes that behave as if they are non-cohesive (22). Hence, even though Chang's model faithfully represents hydraulic processes, bank processes intimately involved in meander migration (such as erosion and mass failure of stratified banks with complex profiles) are inadequately represented.

It is these difficulties that led Cunge (173) to conclude, "Existing models should not be taken as representing reality because the complexity of bank characteristics is not properly simulated."

The meander model of Odgaard (41) concentrated on the ratio of near-bank, depth-averaged velocity to the section-averaged velocity. This model builds on the theoretical model of Ikeda et al. (47) to predict the increase in near bank scour depth (and related bank retreat) as a function of this velocity ratio. In a companion paper (42), the model is applied by linearization of the flow equations, which renders it inapplicable to bends with large curvatures. The modeling approach of Odgaard (41) has many positive attributes, although its theoretical basis is weak in that it does not account for the convective accelerations now known to be central to control of flow patterns at bends (25).

Ikeda et al.'s (47) model also formed the basis for a simulation model for meandering rivers developed by Sun et al. (174). The results of this model demonstrate that meander wavelength is determined mostly by discharge and valley slope and is essentially independent of differences in the erodibilities of sedimentary deposits. This finding is consistent with empirical equations that relate wavelength to bankfull discharge and channel width alone. Sun et al. (174) conclude that at that time numerical simulations were capable of realistically reproducing meander configuration observed in nature. They did not, however, address meander change or migration.

Geomorphologists have developed a number of models of channel planform evolution and the floodplain morphology that results from lateral reworking by meanders. Howard (110) provides an excellent review of available methods and presents the latest version of his own model (175). This employs the bend theory of Parker to predict how a meandering reach evolves through time, stressing the importance of changes in upstream and downstream bends on the behavior of each modeled bend. Geomorphic models such as Howard's are able to create planform patterns and bend behaviors that appear similar to those of meandering rivers in general, and they are able to reproduce the changes displayed historically by particular rivers through hind casting. However, they are not able to predict *a priori* the future evolution of real systems due to lack of information on details of bank material properties that may be encountered by a particular bend. The problem that arises is that an error in prediction for a single bend quickly propagates to bends up and downstream, so that the predicted planform position and pattern diverges from that actually occurring due to the sensitivity of the models to up and downstream feed back effects.

The work of Ligeng and Schiara (176) and Levent (177) represent typical examples of attempts to produce engineering equations to predict meander movement. Ligeng and Schiara (176) took the basis for their approach from the hypothesis that meander bend expansion is caused mainly by erosion of the concave bank. Based on this principle they produced a formula relating expansion to outer bank planform concavity:

$$C = 1.15 \left(\frac{r^{0.98}}{W^{1.1}} \right) \approx 1.15 \left(\frac{r}{W} \right)$$

where:

C	=	bend concavity
r	=	radius of outer bank at bend
W	=	channel width

They concluded that maximum bend expansion occurs when the bend concavity is equal to 0.5 to 0.65. This equation is consistent with historically observed records of bend growth, but adds little to the wider generalizations of Hickin and Nanson regarding the relationship between bend curvature and migration rate.

Levent (177) developed a theoretical model for meander bend expansion and amplitude increase based on bed sediment transport and continuity and validated it using experimental data. The resulting equation is:

$$q_{bwh} = \left(\frac{h_u L}{n} \right) \left(\frac{d_{yb}}{dt} \right)$$

where:

q_{bwh}	=	bed load carried by the whole channel at the meander bend
h_u	=	flow depth at meander bend axis
L	=	meander bend length
d_{yb}/dt	=	rate of bend expansion
n	=	constant

While such equations are potentially useful in that they have a theoretical basis and are expressed in simple forms, their applicability is limited by the use of input variables that are rarely known in practice (for example, bed load carried at the bend) and by the requirement to calibrate the equation for the river in question to find the appropriate value for constants such as n.

In a thorough review of mathematical models of river planform changes, Mosselman (178) discussed the utility of several 2-dimensional, depth averaged models. He concluded that while these models were able to help in understanding how river planforms evolve, none of them had reached the level of being a generally valid and easy to apply software package suitable for routine application.

Cherry et al. (48) used historical records of bend movement for 26 study sites selected from the Brice collection to test the utility of Garcia et al.'s (46) analytical model of bend migration. Their findings were not encouraging and they recommended against attempting to apply analytical models to make routine prediction of meander movement. (For further discussion see Evaluation of Analysis Options.)

The diversity of processes and forms present in natural, meandering rivers means that, even assuming that the governing equations are fully understood and are correctly formulated mathematically, a single computational model is unlikely to have universal validity. Instead computational models are developed to simulate specific, idealized representations of natural fluvial systems (179).

The literature reveals that a wide variety of empirical, analytical, and numerical models of meander migration (47, 174, 180, 181, 182, 183), flow and sediment transfer (25, 163, 164, 184, 185, 186), bend scour (113, 114, 187, 188), sediment sorting (188), and hydraulic geometry (20, 91) have been formulated, and each of these models has their own particular advantages and limitations.

Most empirical and analytical models of meander morphology are limited to ultimate or fully-formed meanders. While these models have had success in predicting equilibrium meander forms, they provide no information concerning the rates and mechanisms of adjustment.

Meander migration is usually simulated using a functional relationship between bank erosion rate and near-bank flow velocity, using a proportionality coefficient determined by calibration (41, 42, 47, 137, 174, 180, 183). Such models are idealized, non-mechanistic, representations of the bank erosion process.

Many existing models are restricted to artificial morphologies tied to idealized representations of the river planform, such as the sine-generated curve. Such representations have in the past proved a useful means of simplifying the governing curved flow equations. However, in simulating real meanders that diverge from these idealized planforms, numerical problems are introduced due to grid distortion. Meandering rivers commonly have asymmetrical bends and non-uniform widths, so models which utilize idealized representations of planform are limited in scope.

The applicability of existing modeling approaches is limited because they do not account for all the degrees of freedom involved in channel adjustment. Rivers adjust to changes in control variables through mutual adjustment of channel roughness, planform, width, depth, gradient, and boundary material characteristics (189). However, existing meander models neglect the adjustment of channel width through time (190). This is despite the fact that channel changes are often dominated by width adjustment (189, 191, 192). Thorne and Osman (113, 114) and Darby et al. (193) have shown that neglecting width adjustment in models of river channel morphology seriously biases predictions of bed-level change in rivers with erodible banks. The development of mechanistic width adjustment models therefore remains a research priority (194, 195).

Technical Problems Related to Meander Measurement, Characterization, and Monitoring

To apply any of the empirical or numerical methods to predict meander movement requires accurate measurements of meander planform. Measuring and characterizing meanders and meander migration are by no means straightforward tasks. For example, Andrieu (196) discusses several potential sources of errors in measuring meander wavelength and sinuosity.

Downward et al. (197) produced a method for quantifying river channel planform change using GIS to produce vector overlays, area map overlays and historic stability overlays. They point out the advantages of GIS-based approaches, including:

- Digitized boundaries provide geometrically stable representations that are easily manipulated
- Aids in the correction of planimetric errors
- Quantitative analysis of linear and areal displacements
- Variety of map products can be produced
- Digital GIS statistical outputs can be exported directly into other software

Gurnell et al. (198) applied the GIS approach proposed by Downward et al. (197) to a study of subtle changes on a single meander of the Lower River Dee in Wales. They emphasized the importance of using GIS to map channel migration and narrowing at a decadal scale.

Unless measurement errors can be kept within acceptable limits then it is impossible to judge whether apparent changes in meander geometry or position are real or the product of measurement error. In this regard the use of GIS technology provides a useful tool for making measurements accurate, precise, objective, and repeatable.

Summary

The review of the literature on meander growth and migration indicates that while the occurrence, patterns, and sequences of meander growth and migration have been well-documented, it is very difficult to predict the magnitude, direction, and rate at which changes will occur. Relations between bend geometry and controlling variables such as discharge and channel width allow reasonably accurate predictions of equilibrium meander geometry. However, it is much more difficult to predict meander migration and channel sinuosity changes. Geomorphic and engineering equations based on flow theory and empirical observations from historical maps and aerial photographs illustrate general relations, but there remains great variability due to variables unaccounted for in the equations. Experimental and practical studies demonstrate that with additional information on channel morphology and bed and bank sediments the ability to predict meander shift may be greatly improved. It is clear that prior screening of bends to exclude those that display meander-like behavior, although they are part of a multi-channel system, is essential to successful predictions. Also, classification of the type of sinuosity present in single-thread, meandering streams greatly enhances predictive confidence. At the very least, the recognition that bends of equal channel width are relatively stable in contrast to meanders with variable width, should be of significance to the highway engineer. This simple observational criterion could eliminate many rivers from concern.

In spite of evidence that the prediction of meander shift using numerical models is possible in principle, many difficulties remain unresolved with this approach. Most models require field calibration that demands unrealistic lead times before predictions can be obtained. Also, the input data required is simply unavailable for most streams, while the models themselves use highly simplified forms of the equations of motion for curved flow that may be challenged theoretically. Few models consider all of the processes known to be involved in meander migration and those that do are impractical for routine use due to their complexity and need for very accurate field data. In any case, sedimentary and geologic controls within the floodplain that cannot be detected in advance may interrupt progressive meander migration and cause deformation of the bend (Table 1 - 4, 5). In addition, changes of the meander pattern itself can complicate the bend behavior (Table 1 - 8, 9, 10) and, finally, human activities can have significant impacts (Table 1, 11, 12, 13, 14). As a result, a river may be composed of reaches of very different morphology, which requires that each meander must be described quantitatively, and predictions made for a single meander may not be transferred directly to another meander. However, this complexity in itself provides valuable information that can be used to improve prediction of meander behavior.

The conclusion to be drawn from this literature review is that the only complete model of a river is the river itself. While the past behavior of a meandering reach is not necessarily indicative of its future behavior, at least the historical record integrates the effects of all the relevant variables as they operate in that location. If changes in flow regime, sediment availability, bank materials or human activities are known to have occurred during the period of record, the response of the river in the past can indicate how the river may respond to continued changes in the future. It appears that, provided the planform evolution of the study reach can be accurately chronicled using aerial photographs and GIS techniques, a reliable basis exists for prediction by extrapolation on the basis of meander class and style of change, adjusted where appropriate, to account for changes known to have occurred during the period of record or believed to be likely to occur during the period of prediction.

EVALUATION OF ANALYSIS OPTIONS

The Johns Hopkins Study

A study by Johns Hopkins University (48) for the U.S. Army Corps of Engineers Waterways Experiment Station investigated the use of both empirical and analytical approaches to provide solutions to the problem of predicting meander migration. Two approaches to prediction were evaluated: (1) the use of empirical (statistical) relationships between planform characteristics and controlling variables such as discharge, sediment loads, stream or valley gradient, and (2) the use of flow-based computational meander migration models.

This Johns Hopkins study evaluated these two methods for forecasting planform change and bankline migration using data originally assembled and analyzed by Brice (49) to assess stream channel instability problems at bridges for the Federal Highway Administration (FHWA). Of the 350 sites in the Brice collection, 133 of the meandering river sites which included a time series of aerial photography and a nearby stream gage, were used in the Johns Hopkins

evaluation of empirical relationships. Brice's data included the following: channel width, meander wavelength, sinuosity, gradient, valley slope, drainage area, erosion rate and some hydrologic data. Measurements of additional meander properties were made for the Johns Hopkins study. Local channel curvature and local bank erosion were measured for a smaller group of 26 sites. These 26 sites were used to evaluate the predictive capabilities of bend-flow meander migration computer models. The computational bend-flow meander migration model used in the study was developed by Garcia et al. (46).

Empirical Relationships

As pointed out in the Johns Hopkins report (48), the basic strategy of the empirical approach is to find "simple" relationships between easily measured variables and the planform characteristics to be predicted. The Brice data set was used to develop and evaluate several single variable regression relationships. To evaluate the capabilities of computer modeling in predicting meander migration, Johns Hopkins also tested the bend-flow model of Ikeda et al. (47), which attempts to predict analytically the depth-averaged velocity at every point in the channel. The Johns Hopkins study did not report promising results with either approach; however, only single variable regressions based on the supplemental field data available from Brice were evaluated.

The study recognized that a meandering river is a complex system involving relations among many variables. The erosion rate for a meander bend is determined by the balance between the erosive forces applied to the channel bank and the resistance to erosion provided by the bank material and bank vegetation. Erosive force is a complex function of discharge, channel cross section geometry, sediment load, bed roughness, presence of bedforms and bars, and the planform geometry. Resistance to erosion is related to the properties of the bank material, the bank geometry (slope, height, shape), the presence of vegetation, and the state of the pore water in the bank (48). Although simplified, single valued correlations between a number of variables were established empirically and expressed as power functions, Johns Hopkins concluded that they did not adequately describe meander behavior.

The Johns Hopkins study concluded that "clearly, this multidimensional variability cannot be captured in a simple regression equation," and noted that other than descriptive data on bank material type, the Brice data set does not include parameters to characterize the erodibility of the bank material. Even with this limitation, several useful empirical relationships were developed. Channel width was found to give more precise forecasts of meander spacing and reach-averaged erosion rates than discharge. Channel curvature provided the best empirical forecast of local and bend maximum erosion rates. For 26 study sites, local erosion direction was accurately predicted, on average, for 62 percent of a given meandering reach.

Bend-Flow Meander Migration Models

In regard to computer modeling, Johns Hopkins points out that a number of authors have developed versions of the bend flow model (41, 42, 46, 137, 149, 180)) and although the models have typically been tested with plots of predicted vs. observed channel form for a limited number

of channels, there has been little general testing of these models over a range of hydrologic and geologic conditions.

After testing the bend flow model for 26 of the meandering sites in the Brice data set, the Johns Hopkins study concluded that both the accuracy and applicability of the bend-flow meander migration model are limited by a number of simplifying assumptions. Among the most important of these are the use of a single discharge and the assumption of constant channel width, both of which prevent the model from successfully forecasting the spatial and temporal variability that appears to be inherent in the process of bend migration.

It was also concluded that much of the discrepancy between the predicted and observed distributions of erosion can be accounted for by the fact that meander migration is modeled as a smooth, continuous process. In reality, erosion occurs predominantly in discrete events, and varies greatly both temporally and spatially along the channel from bend to bend (90). The Johns Hopkins study noted that the identification of local factors that influence the amount of bank erosion that occurs is a subject "that will require further investigation." The faculty co-author of the Johns Hopkins study concluded that "further refinements in bend-flow modeling will not improve our predictive capability until we find a more rational way to wed the flow model to a bank erosion model."

In addition to channel and bank characteristics, floodplain characteristics must also be incorporated into an analysis procedure. The floodplain characteristics that should affect meander migration include geologic controls, alluvial deposits and topographic variability. Geologic controls include bedrock outcrops and erosion resistant features along the valley sides. Alluvial deposits frequently include oxbows, meander scrolls and scars, and clay plugs, each with different erodibility characteristics. Topographic variability that should be considered include the cross valley slope of the adjacent floodplain and valley slope.

The Federal Emergency Management Agency Evaluation

The Federal Emergency Management Agency (FEMA) published a report which evaluates the feasibility of mapping Riverine Erosion Hazard Areas (REHA) (199). This study addresses requirements in the National Flood Insurance Reform Act (NFIRA, September 1994) which requires that FEMA submit a report to Congress that evaluates the technological feasibility of mapping REHAs and assesses the economic impact of erosion and erosion mapping on the National Flood Insurance Program (NFIP).

In regard to mapping REHA, FEMA's concern is both channel instability (erosion) induced by natural and human processes and lateral migration. Technological feasibility means that there are methodologies that are scientifically sound and implementable under the NFIP. Scientific soundness means that the methodologies are based on physical or statistical principles and are supported by the scientific community. Implementable means that the approaches can be applied by FEMA as part of a nationwide program under the NFIP and for an acceptable cost.

The FEMA project team conducted a search of existing methodologies used to predict riverine erosion, with emphasis on case studies. In general, case studies were categorized as:

- Geomorphic methods - relying primarily on historic data and geomorphic investigations;
- Engineering methods - relying primarily on predictive equations based on engineering and geomorphic principles, and
- Mathematical modeling methods - relying primarily on computer modeling of fluvial processes.

A Project Working Group (PWG) of experts in the field of riverine erosion was organized. Their functions were to provide guidance to FEMA on technological feasibility of mapping REHAs, to act as an information source to locate and select case studies, and to review and comment on reports prepared during the study. The PWG included a nationwide mix of individuals from academia; Federal, State, regional, and local government; and the private sector.

Riverine Erosion

The following observations on riverine erosion are extracted (generally verbatim) from the Executive Summary of the FEMA study (199).

Fluvial systems respond to perturbations that may be the result of naturally occurring inputs, such as precipitation, or human intervention in the form of urban development, forestry, mining, flow diversions, flood regulation, navigation, and other activities. Complex physical processes whose mathematical characterization is still imperfect govern the response, although there is reasonable qualitative understanding of the nature of this response.

In the context of riverine erosion hazard areas, engineers are mostly concerned with migration of the channel alignment and various forms of erosion and deposition. Numerous factors affect the spatial and temporal response of a stream channel. These factors encompass various aspects of geomorphology and fluid mechanics and include fluid properties, sediment characteristics, discharge, sediment transport, channel geometry, and fluid velocities. The behavior of these variables depends on the time scale under consideration: short-term, long-term, and very long (geologic) term. For example, channel geometry can be considered relatively constant in the short-term of a few weeks but highly variable in the geologic time frame.

For most practical applications, engineers are interested in phenomena that take place in the short- and long-term; thus, certain variables can be considered independent. For instance, in the geologic time frame, valley slope is a function of geology and climate; however, short- and long-term channel formation processes occur at a much faster rate, and valley slope can be considered independent in many instances. For short- and long-term analyses, it can be assumed that the discharge regime and sediment supply are the driving variables that act on channel boundaries and vegetation to produce changes in channel cross section, longitudinal profile, and alignment.

The FEMA study defines lateral migration as shifting of the streambank alignment due to a combination of vertical erosional and depositional processes (degradation, aggradation, and scour). The most common example is meander migration in the floodplain. Bank retreat due to mass failure is another example.

Evaluation of Channel Changes

The FEMA study concludes that mathematical representation of fluvial fluid mechanics is difficult due to imperfect knowledge of the complex physical phenomena involved. The many attempts to modeling of fluvial processes have shortcomings largely due to the fact that sediment transport equations commonly overpredict or underpredict sediment loads by orders of magnitude of actual measured sediment transport rates.

Some analysis methods are based on the hypothesis that the stream system tends toward a state of dynamic equilibrium in which the channel adjusts to changes in the water and sediment supply regimes. These methods include simple equations called "regime relationships," techniques based on mechanical stability conditions, and complex computer models. These equilibrium-based approaches have difficulties in accounting for ever-changing land use conditions.

In addition to fluvial processes, numerous climatic, environmental and geotechnical factors are involved. Hydrodynamically induced erosion and deposition and the occurrence of mass failure of the streambanks drive channel cross sectional changes. Induced effects include changes in roughness, bed material composition, vegetation cover, and planform. Prediction of cross sectional adjustments can only be accomplished for site-specific conditions after the most significant geomorphological factors have been identified. Therefore, any prediction of channel geometry should be based on sound field observations.

The FEMA study team evaluated several hundred pieces of literature and after an initial screening, 108 articles and reports were evaluated to compile methods currently in use to predict channel changes. Of this set, 12 case studies were selected for detailed review. In assessing the technical feasibility of mapping REHAs, each case study was analyzed for applicability, limitations, potential for mapping riverine erosion, cost, and regulatory potential. These documents revealed that numerous techniques are currently in use covering geomorphic methods, basic engineering principles, and mathematical modeling.

Conclusions from the FEMA Study

The FEMA study concluded that the case studies indicate that there are scientifically sound procedures for delineating riverine erosion hazard areas. Various geomorphic, engineering, and modeling procedures can be applied, depending on site-specific conditions. Specialized knowledge and experience are needed to draw conclusions that would lead to delineation of a hazard area. Given a suitable time frame, future erosion could be estimated either extrapolating from historic data or through the use of mathematical models. In both cases, an estimate of the reliability of the prediction needs to be provided.

Riverine erosion is a complex physical process that involves interaction of numerous factors: fluvial hydraulics, geotechnical stability, sediment transport, and watershed characteristics, including hydrology and sediment yield, past and future land use, and vegetation among others. The study of riverine erosion is multidisciplinary in nature and requires experienced geomorphologists, hydrologists, hydraulic engineers, geotechnical engineers, photo-

interpreters, planners, and mapping specialists. Some of these professions require advanced degrees in their specialties. Valuable input is also needed from local floodplain managers. **Modeling is the most complex approach, and its implementation requires considerable expertise and resources (emphasis added).**

Despite decades of research into the physical processes associated with riverine erosion, knowledge of the subject is still imperfect, and much work remains to be done. Accurate mathematical representation of these processes has not been achieved yet, and available tools produce results surrounded by varying degrees of uncertainty. Nevertheless, there are analytical procedures that can be used to characterize riverine erosion and that, depending on the application, can yield reliable results. For example, because of limitations in data availability and model capabilities, it is extremely difficult to reproduce detailed time variation of stream movement; however, it is entirely feasible to analyze channel history and infer trends in the stream alignment and average migration rates.

Data Needs

Both the literature review and evaluation of analysis options support an empirical approach to predicting channel migration. It is useful, however, to discuss the data requirements of empirical versus deterministic approaches. For the purposes of this discussion, empirical approaches are assumed to be primarily statistical, while deterministic approaches account directly for the physical processes responsible for, in this case, channel migration. The division between empirical and deterministic approaches is not absolute, but a matter of degree. The selection of dependent and independent variables and the success of a statistical analysis relies on an understanding of the dominant physical processes. Conversely, when the physical processes are extremely complex, as is the case with channel migration, a completely deterministic model may be impossible to develop. Therefore, deterministic models for channel migration must incorporate simplifications of the physical processes and are, to some degree, empirical. An example is the Garcia et al. (46) model presented in the Johns Hopkins (48) report. In this bend-flow meander migration model, an erosion coefficient is calibrated by fitting observed and computed channel planform. The erosion coefficient relates channel migration rates to velocity and channel width, but clearly does not address the physical processes controlling bank retreat.

Empirical Approach

A statistical approach can be viewed as pure data analysis, meaning that one only needs data and does not need to understand the physical processes in order to perform the analysis. Certainly, the data must be selected carefully to accurately represent the physical processes. Although the process based modeling approach could have been adopted for this project, there remains a significant level of uncertainty related to the processes of channel migration. This level of uncertainty is evident in the use of an erodibility index that is incorporated into several models. It is a lumped parameter involving many different material characteristics and physical processes.

Statistical analyses, typically regression, also involve uncertainty for a variety of reasons. (1) Processes are represented by surrogate parameters or lumped parameters such as the erodibility index described above. An example of a surrogate parameter would be the use of width-depth ratio as a measure of bank erodibility because lower width depth ratios indicate relatively higher bank erosion resistance. (2) The data used for development of regression equations must represent the range and variability of data used for its application. If this is not the case, there will be situations where the equation should not be used and, if used, will result in additional potential error due to extrapolation. (3) The data will over represent some conditions and under represent others. This is similar to the second case except that, while the results may be valid for the well represented conditions, there is a bias incorporated into the predictions. (4) The form of the regression equation is unknown. In the data analysis process, various forms of the equation will be reviewed. Some of the processes may be related linearly with channel migration while other may be exponentially related. (5) Statistical requirements may not be satisfied. Standard regression analyses assume that the scatter of observations are normally distributed relative to the prediction. If the normal distribution requirement is not satisfied, there may be bias in the predictions. This can be addressed through other "non-parametric" statistical techniques.

Deterministic Approach

From a purely deterministic model or process-based approach, the model should be able to simulate the actual migration of a meander. The computational properties of such a model would include: (1) The model would need to simulate the hydraulics and sediment transport processes through time, potentially in a 3-dimensions and simulate both channel and overbank flow conditions. (2) The model would have to simulate erosion processes (grain-by-grain detachment), mass failure processes (bank failure), and account for the subsequent removal of the material that accumulates at the bank toe from the mass failure. (3) The model would have to incorporate the reinforcing strength provided by roots and potentially the surcharge from the mass of trees. (4) The model would have to be able to revise the channel geometry and account for changes in boundary material as migration exposes new materials. (5) The model would have to incorporate varying hydrology (actual flow record) and some aspects of weather because saturation of the bank materials affects the unit weight of the bank material as well as the internal friction angle and cohesion.

This purely deterministic model, starting at some historic condition, would simulate flow and sediment transport conditions for a hydrologic and weather record. The model would simulate the erosion and mass wasting of bank material and accretion of the opposing point bar. It would then be able to replicate the actual channel development for the historic period. To predict future channel migration, the model would use representative long-term hydrology and weather conditions. This model would not incorporate empirically derived variables because all the input would be measurable and the model would be applicable to all river types and conditions.

The data requirements to develop and apply such a model are extreme. The hydrology and weather data would have to be known for a significant period of record. The model would need to include bed and bank material properties as they vary spatially and temporally. Bank

material properties would need to be determined for the various strata comprising the bank. These properties include not only grain size and erodibility, but also mechanical properties such as shear strength, angle of internal friction and cohesion for varying soil moisture and saturation. The mechanical properties of tree roots would also have to be quantified.

This model would be so complex that its development is, arguably, impossible. It is as unrealistic as suggesting that one regression equation could be used for all rivers types and that the regression equation would rely on a single independent variable. Some middle ground was necessary to achieve the goals of this project (1) reasonable predictions of meander migration and (2) practical use of the final procedure. That middle ground could be a deterministic model that uses empirically derived variables or a statistical analysis of physically meaningful variables. Making use of the photogrammetric comparison procedures necessary to developing the data base for a statistical analysis could also provide a "model" for predicting future channel position based on observed historic trends.

Some level of simplification is needed for each of the properties of the deterministic model outlined above. Hydraulically, a 2-dimensional bend-flow model would appear to be most appropriate, but use of 1-dimensional models simplify the input and data requirements. Simulating a long-term flow record, including low, moderate and extreme flow conditions would also be arduous. Use of a single, channel forming or effective discharge is a common technique to simplify this aspect of the problem. Sediment transport analyses inherently include significant complexity and uncertainty. This process would need to rely on a variety of sediment transport formulae for various size sediments. Finally, the geotechnical investigations required to describe the spatial variability of the bank materials could rival the effort of performing the bend migration simulations. Temporal variability of bank material properties would probably need to be eliminated to reduce computational requirements. These simplifications could be made and the model could still be considered as deterministic, especially if the processes of bank erosion and failure were addressed from a physical standpoint. Mass bank failure is related to the mechanical properties of the bank materials and removal (erosion) of toe support. Removal of toe support occurs either laterally or through channel degradation. Therefore erosion and mass failure need to be addressed as well as sediment transport. From this viewpoint the Garcia et al. (46) model is deterministic in many ways, but not with regard to the processes of bank retreat. In their model the erosion coefficient is calibrated based on observed migration rates. To improve the utility of this approach the erosion coefficient would have to be related to other measurable properties of the bank material and vegetation conditions.

There are other models that treat bank retreat in a deterministic manner. Osman and Thorne (143) and Thorne and Osman (114) provide an excellent example of combining hydraulics, sediment transport and bank stability processes that could be extended, with considerable effort, into a more comprehensive migration model. However, the effort required to produce such a migration model would not only exceed the resources available for this project but would result in a product too complex for widespread use.

A list of the data required by the Osman and Thorne model includes: channel geometry (average depth, central depth, flow depth at radial distance r , bend radius of curvature, bank height, bank angle, width, channel slope), discharge, bed material median size, largest size and

median fall diameter, cohesion, effective cohesion, pore fluid salt concentration in the bank material, sodium absorption ratio of the bank material, dielectric dispersion of the bank material, unit weights of the bed and bank materials, angle and effective angle of internal friction, friction factor and Manning n, bed material porosity and ratio of tension crack depth to bank height. Many of these parameters can be reasonably estimated, but the amount of data required is still much greater than could normally be justified for the purposes of a meander migration estimate. It is also clear that use of this model would require significant expertise in hydraulics, sediment transport, geotechnical engineering and hydraulic modeling.

Summary

Review of the literature, evaluation of analysis options, and consideration of data needs for empirical and deterministic (physical process mathematical modeling) approaches to predicting meander migration support the finding that empirical approaches are more likely than deterministic approaches to yield a practical methodology that will be useful to practicing engineers. A comparison can be drawn between predicting meander migration and the current practice for predicting scour at bridge piers. The current practice for pier scour is to use empirical equations that relate pier geometry and hydraulics to potential pier scour. Alternatively one could use physical modeling for complex pier shapes or sophisticated 3-dimensional flow and erosion computer modeling. The physical and numerical modeling are, to varying degrees, limited by several factors. These include time, cost, scale effects, and the ability to characterize the erosion properties of some sediments. Numerical and physical modeling are useful tools and expand our knowledge of pier scour, but could not replace the utility of the empirical equations for practical problems.

CLASSIFICATION AND SCREENING PROCEDURES

Objective

The objectives of this project included developing a quantitative screening procedure to identify stable meandering reaches. This information will be significant to both bridge design engineers and bridge inspectors and provide a basis for concentrating design and inspection resources on less stable problem reaches.

Classification Concepts

Channel classification systems provide engineers with useful information on typical characteristics associated with a given river type and establish a common language as a basis for communication. Classification requires identifying a range of geomorphological channel types that minimizes variability within them and maximizes variability between them (200). Given the complexity of natural systems, inevitably some information is sacrificed in the attempt to simplify a continuum of channel geomorphic characteristics into discrete intervals for classification.

Rivers are often categorized as either straight, meandering, or braided. These categories identify the three major alluvial river types. An alluvial river is one that is flowing in a channel

that has bed and banks composed of sediment transported by the river. That is, the channel is not confined by bedrock or terraces, but it is flanked by a floodplain. In addition to these three basic river "types," there are also anabranching alluvial rivers and rivers that are termed wandering. Brice (72) illustrates the range of channel types for meandering, braided, and anabranching channels (Figure 10).

Figure 10 shows the difference between low sinuosity, straight channels and meandering channels, as well as the difference between bar-braided and island-braided channels. It also demonstrates that the braided river occupies one channel whereas the anabranching channel has multiple channels separated by a vegetated floodplain. On Figure 10 the degree and character of sinuosity portions are related directly to the objectives of this project. The braiding and anabranching processes, while of interest, were not considered in the scope of this project.

Classification and Screening

A wide range of channel classification approaches (72, 126, 201, 202, 203, 204, 205, 206, 207) were considered as a basis for developing procedures to screen sites that would have a high probability of being stable and to classify sites by meander mode as a means of segmenting the data base. It was concluded that a channel pattern classification originally developed by Brice (72) could be used as a basis for both screening and classification (Figure 10). The "character of sinuosity" portion of this classification provides both a screening and classification procedure. Based on original work by Brice, which was validated and expanded on with sites in the data base developed for this project, sites that have the equiwidth characteristic could be screened into a "stable" class and given a low priority for further analysis.

Modifications were made to the Brice classification to support the specific objectives of this project. As shown in Figure 11, nine screening and classification categories can be used to represent the full range of meandering rivers encountered in the field. As noted above, equiwidth rivers, such as A, B₁, and G₁, can be screened as stable. One class, the "wandering" river shown as F, should be screened as potentially so unstable and unpredictable that further evaluation would not be likely to produce a meaningful result (in terms of predicting meander migration). All other meandering rivers can be classed as one of the remaining five categories, B₂, C, D, E, G₂, and analyzed by the photogrammetric comparison techniques presented in the Handbook developed for this project.

Application of this procedure to 58 Brice sites indicated that all sites fit into one of the categories, without apparent anomalies, and the classification results were replicable. Additional verification of the validity and applicability of this classification and screening procedure was provided by regression analysis (see the next section).





























Degree of Sinuosity	Degree of Braiding	Degree of Anabranching
 1 1-1.05	 0 <5%	 0 <5%
 2 1.06-1.25	 1 5-34%	 1 5-34%
 3 >1.26	 2 35-65%	 2 35-65%
 3 >65%	 3 >65%	 3 >65%
Character of Sinuosity	Character of Braiding	Character of Anabranching
 A Single Phase, Equiwidth Channel, Deep	 A Mostly Bars	 A Sinuous Side Channels Mainly
 B Single Phase, Equiwidth Channel	 B Bars and Islands	 B Cutoff Loops Mainly
 C Single Phase, Wider at Bends, Chutes Rare	 C Mostly Islands, Diverse Shape	 C Split Channels, Sinuous Anabranches
 D Single Phase, Wider at Bends, Chutes Common	 D Mostly Islands, Long and Narrow	 D Split Channel, Sub-parallel Anabranches
 E Single Phase, Irregular Width Variation		 E Composite
 F Two Phase Underfit, Low-water Sinuosity		
 G Two Phase, Bimodal Bankfull Sinuosity		

Figure 10. Channel pattern classification devised by Brice (after (72)).







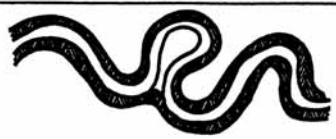

MODIFIED BRICE CLASSIFICATION		SCREEN
	A SINGLE PHASE, EQUIWIDTH CHANNEL INCISED OR DEEP	*
	B ₁ SINGLE PHASE, EQUIWIDTH CHANNEL	*
	B ₂ SINGLE PHASE, WIDER AT BENDS, NO BARS	
	C SINGLE PHASE, WIDER AT BENDS WITH POINT BARS	
	D SINGLE PHASE, WIDER AT BENDS WITH POINT BARS, CHUTES COMMON	
	E SINGLE PHASE, IRREGULAR WIDTH VARIATION	
	F TWO PHASE UNDERFIT, LOW-WATER SINUOSITY (WANDERING)	*
	G ₁ TWO PHASE, BIMODAL BANKFULL SINUOSITY, EQUIWIDTH	*
	G ₂ TWO PHASE, BIMODAL BANKFULL SINUOSITY, WIDER AT BENDS WITH POINT BARS	*
NOTE: WHERE SCREEN = *, CLASS FALLS OUT DUE TO IMPLICATIONS OF CONSIDERABLE STABILITY OR EXCESSIVE INSTABILITY		

Figure 11. Modified Brice classification.

REGRESSION ANALYSIS

Introduction

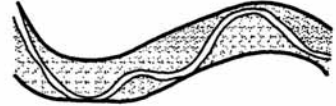
Data from the Brice (72) sites (including data from recent aerial photographs) were used (1) to assess screening and classification procedures, and (2) to establish guidance and limits for predicting meander movement when using photo comparisons. For (1) the data clearly shows that migration rates are related to meander class. Although it was hoped that regression equations could be developed for use in predicting migration when historic aerial photos were not available, statistically significant regression equations were not successfully developed (see Chapter 3 for further discussion). However, for (2), a frequency analysis approach was developed to guide photo comparisons.

The rates of bend expansion, extension, and translation (see Figure 9) were computed for each location and each of three time periods. The bankline data are generally from the 1930s, 1960s, and 1990s. Using the first and second, second and third, and first and third time periods resulted in average intervals of 27, 26, and 56 years, respectively. The data were grouped using Figure 11. The A, B1, B2, and C classes, which included 89, 249, 408, and 915 data points (in the Brice data set), respectively, are included. A sites are single phase, equiwidth, incised or deep. B1 sites are single phase, equiwidth. B2 sites are single phase, wider at bends without bars. C sites are single phase, wider at bends with point bars. The classification based screening was intended to identify river types that would exhibit different channel migration characteristics. The A and B1 sites were expected to exhibit such low migration rates that further analysis would be unnecessary (or low priority). B2 and C sites were expected to exhibit much higher rates of movement and were to receive the focus for prediction techniques. The D, E, and G₂ sites are not well represented in the Brice data set.

Each of the three modes of bend movement are vectors, i.e., they each have a magnitude and direction. Figure 12 depicts the modes of meander movement (positive rates are shown for each mode). The direction for extension is in the bend orientation direction and the direction for translation is in the downstream direction perpendicular to the bend orientation. The bend radius does not have a specific direction. However, if the bend radius is contracting, then the rate of bend radius "expansion" is negative. In order to assess the amount of bank movement, the three vectors measuring migration were combined into a resultant magnitude, termed "apex movement." Apex movement is the movement of the outer bank apex and is computed as the vector sum of the three components of movement at the apex location.

Justification of the Classification System

Figure 13 shows the rates of apex movement in ft/yr for the four classifications plotted as cumulative percent. As anticipated, the A and B1 sites show low rates of movement as compared to the B2 and C sites. One hundred percent of the Brice A sites have rates of movement less than 2.8 ft/yr (0.85 m/yr) and 90 percent of the B1 sites have rates of movement less than 4.2 ft/yr (1.28 m/yr). These rates are approaching the accuracy of the measurements from aerial photography. The B2 and C site bends show similar rates of movement above the 90 percent level and much greater rates of movement than the A and B1 sites. A significant

proportion of the B2 and C bends (40 and 20 percent) show low rates of movement (less than 3 ft/yr). The B2 and C sites also have a significant number of rapidly moving bends. At the 90 percent level the B2 and C bends are moving at a rate of approximately 13 ft/yr (3.96 m/yr) and at the 95 percent level, bends are moving at almost 18 ft/yr (5.49 m/yr). From these statistics, it can be concluded that one in ten C and B2 bends are moving at rates greater than 13 ft/yr (3.96 m/yr) and 1 in 20 are moving at rates greater than 18 ft/yr (5.49 m/yr).

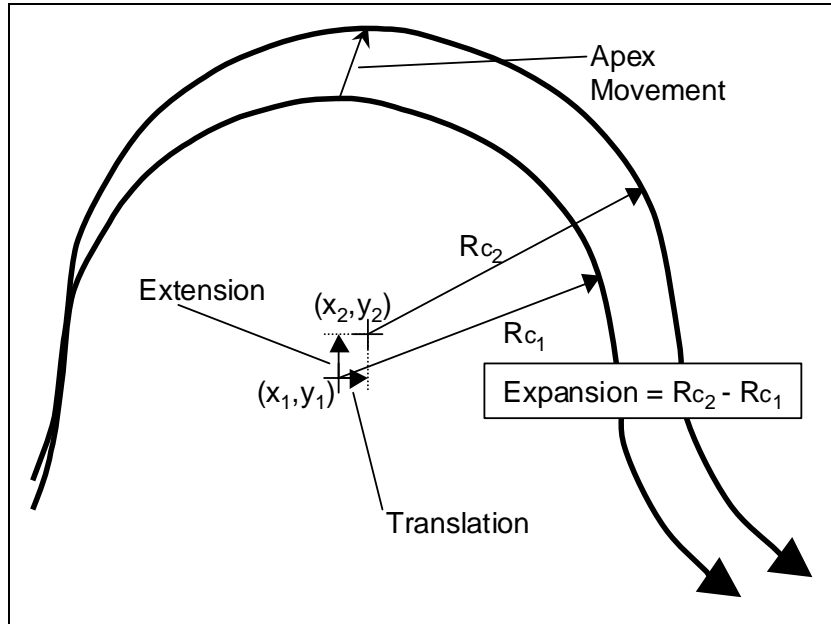

Figure 12. Modes of meander bend movement.

These results may be somewhat biased by scale. The average channel widths of the A, B1, B2, and C sites are 89, 212, 321, and 276 feet (27, 64.6, 97.8, 84.1 m) at the crossings and 104, 238, 382, and 346 feet (31.7, 72.5, 116.4, 105.5 m) (at the bend apices, respectively). Dividing the migration rate by the channel width yields a migration rate in terms of channel widths per year. Figure 14 shows the rates of apex movement in apex widths per year. The A and B1 sites are virtually indistinguishable on a rate expressed in channel apex widths/year. The B2 sites, the widest class, show rates of movement closer to the A and B1 sites. The C sites are not, on average, the widest channels in the data set but do show the greatest rates (in ft/yr). The difference between the C sites and the other classifications is most evident when normalized by the channel width. While Figure 14 still supports the premise that A and B1 sites move less than B2 and C sites, on a normalized basis there is less to distinguish between the first three classes (A, B1 and B2).

The mean, standard deviation, 90th percentile, and maximum rates of apex movement for the four classes of Brice data are shown in Table 2. Each of these statistics indicates that the screening and classification approach is justified and that the C and B2 sites have the greatest potential for migration problems. Although the A and B1 sites do migrate and at normalized rates that are not too dissimilar to the B2 sites, these channels are generally smaller and are, therefore, less likely to cause a problem.

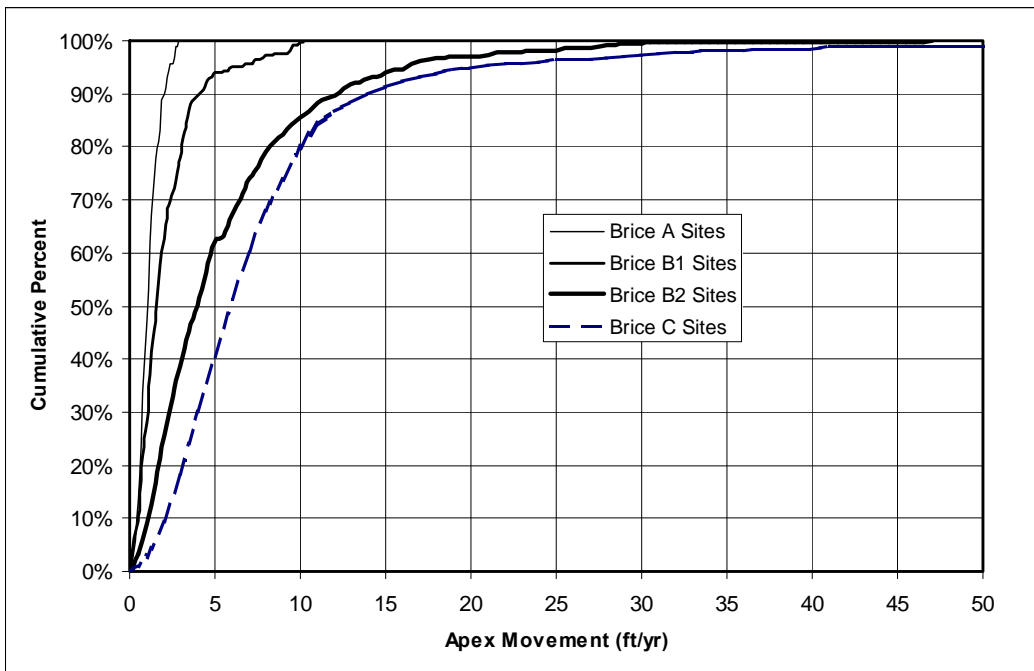

Figure 13. Cumulative percentage of Apex Bend Movement in ft/yr.

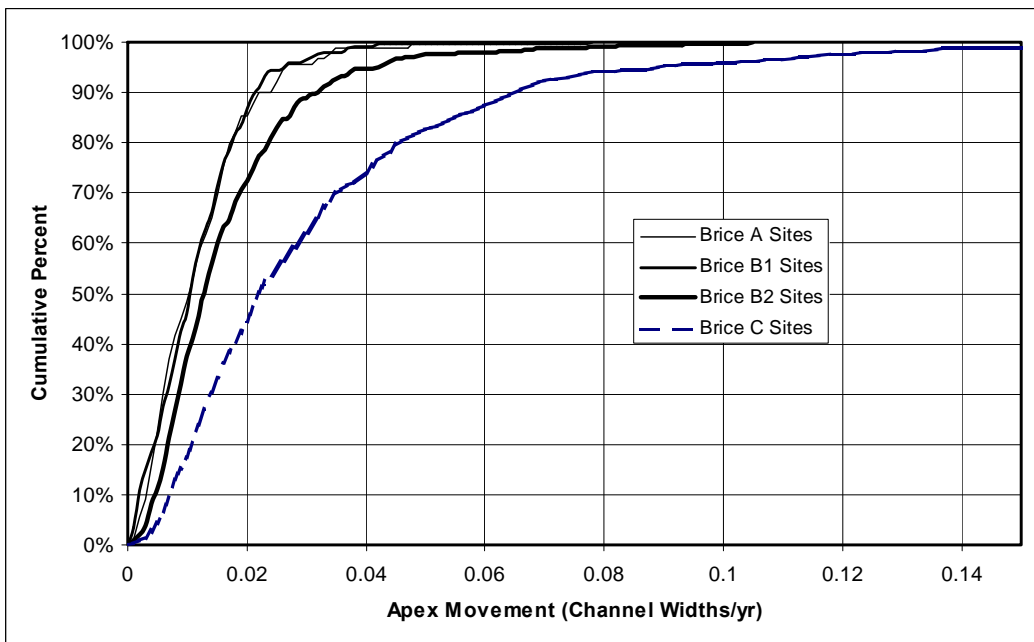

Figure 14. Cumulative percentage of Apex Bend Movement in channel widths/yr.

ft/year	Mean	Std. Dev.	90 th Percentile	Maximum
A Sites	1.1	0.6	2.0	2.8
B1 Sites	2.1	1.9	4.1	10.3
B2 Sites	5.6	5.5	12	47
C Sites	8.0	9.4	14	105
Channel Widths/year	Mean	Std. Dev.	90 th Percentile	Maximum
A Sites	0.012	0.009	0.023	0.048
B1 Sites	0.012	0.009	0.022	0.077
B2 Sites	0.016	0.014	0.032	0.104
C Sites	0.032	0.033	0.065	0.32

Comparison with Other Studies

Nanson and Hickin (91) concluded that the greatest rates of bend movement occur for ratios of bend radius of curvature to channel width (R_c/W) of approximately 2.5 (Figure 15). This study supports that conclusion. Figure 16 shows rates of apex movement (presented as channel widths per year) plotted versus R_c/W . The highest potential for erosion appear to occur at R_c/W values between 2 and 4. It appears that, for a specific channel width, the rate of maximum movement is lowest for long radius bends and increases as the radius decreases. The highest rates of movement occur for bends with R_c/W of approximately 3 and decrease rapidly as the bend radius decreases further. It should also be noted that very low rates of movement also occur for the entire range of R_c/W . So although there appears to be higher potential for rapid movement at R_c/W of around 3, this figure does not appear to provide a significant basis for predicting meander movement. Close examination of Figures 15 and 16 indicates that the lowest rates of movement also occur for R_c/W values between 2 and 4.

Other studies have found weak correlation between erosion rate and other channel or basin characteristics. For example, the Johns Hopkins study (48) found that a power function produced the highest correlation between median erosion rate and channel width ($R^2 = 0.37$). Based on variety of regression relationships (see Chapter 3 for further discussion), similar results were obtain from the Brice site data assembled for this study. Figure 17 shows the poor correlations obtained using apex movement versus channel apex width. The Johns Hopkins study excluded approximately 20 percent of their sites from the regression due to "no detectable erosion." In this study these sites would primarily be classified as A and B1 channels. All of the Brice data from the B2 and C sites are included in Figure 17.

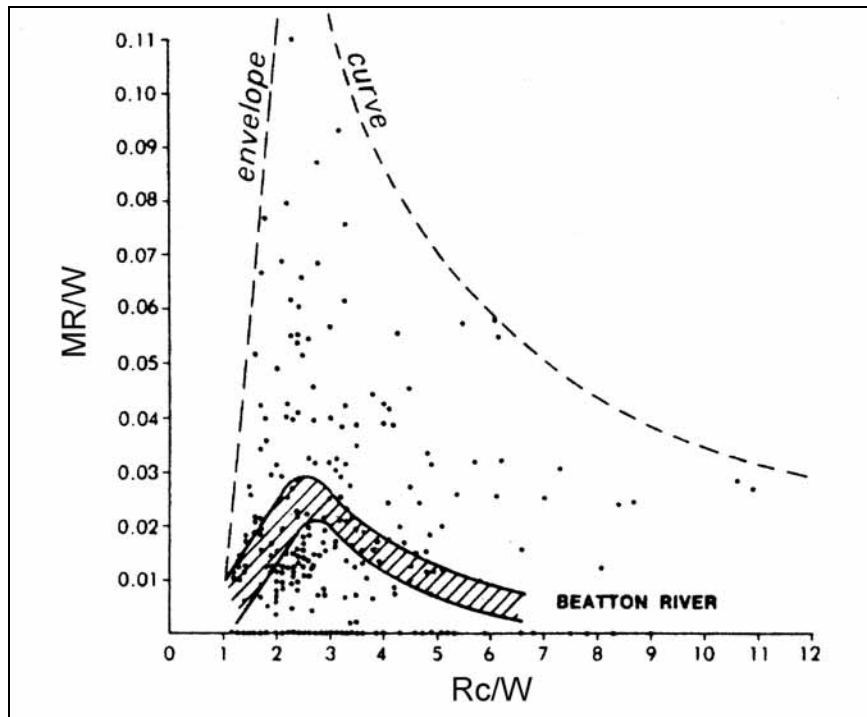

Figure 15. Migration Rate (MR/W) versus Radius of Curvature/Width (91) (see also Figure 7).

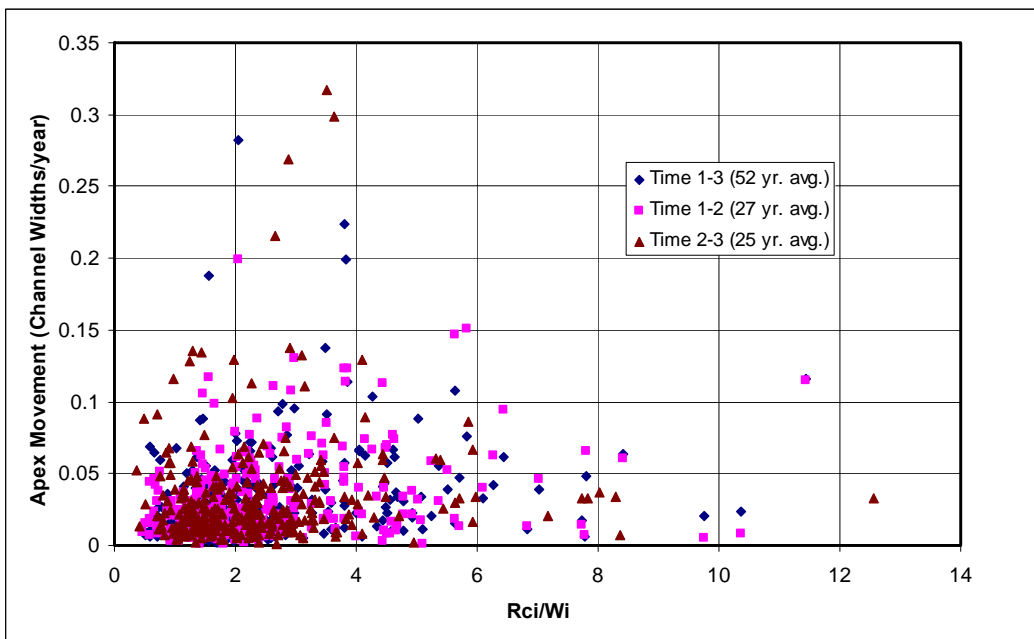

Figure 16. Apex Movement versus Radius of Curvature/Width.

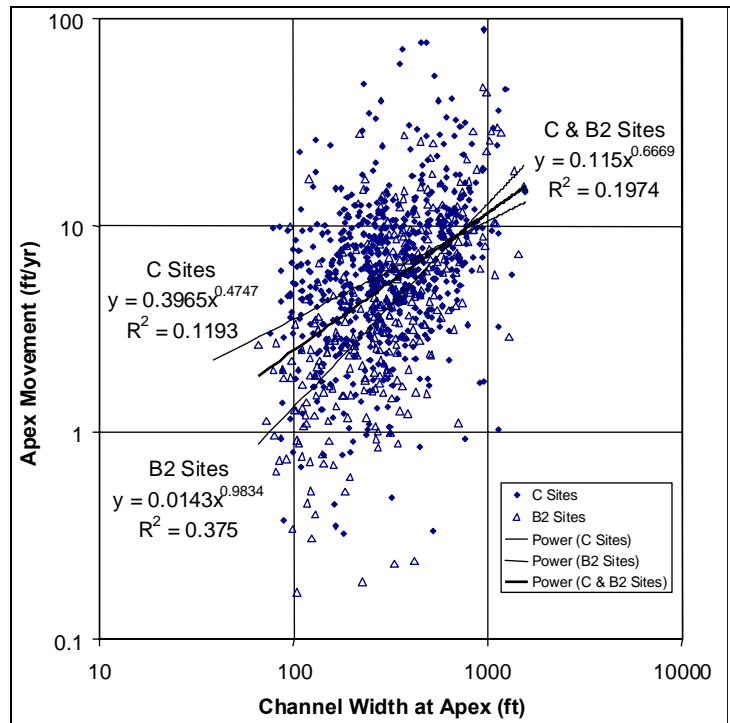

Figure 17. Apex Movement versus Channel Width.

Migration Prediction

One mode of meander migration is radius expansion (Figure 12). Bends can either expand or contract (negative expansion). Figure 18 shows the ratio of bend radius of curvature at the end of a time period to radius of curvature at the beginning of the time period plotted versus initial radius of curvature over width (R_{ci}/W_i , bend tightness). Although there are expanding and contracting bends throughout the range of R_{ci}/W_i , the tighter bends tend to expand and longer bends tend to become tighter by reducing their radius. The data set is dominated by a cluster of data points centered on $R_{cn}/R_{ci} = 1$. A value of one indicates that the bend did not change its radius of curvature, a value greater than one indicates an expanding bend and a value less than one indicates a contracting bend.

Considering bend tightness (R_{ci}/W_i) and time, the best fit equation for the data in Figure 18 yields an $R^2 = 0.23$, indicating that while there is a trend (which is evident in Figure 18), there is significant scatter around the equation. Attempts to improve the predicted radius by including discharge, unit discharge, slope stream power, unit-stream power, grain size, and percent silt-clay did not yield increased R^2 .

The two other modes of meander migration are translation and extension (Figure 12). These modes may also be positive or negative depending on the direction of movement, but they tend to be positive. Statistically significant relationships for extension and translation were also not forthcoming, at least no more so than shown in Figure 17.

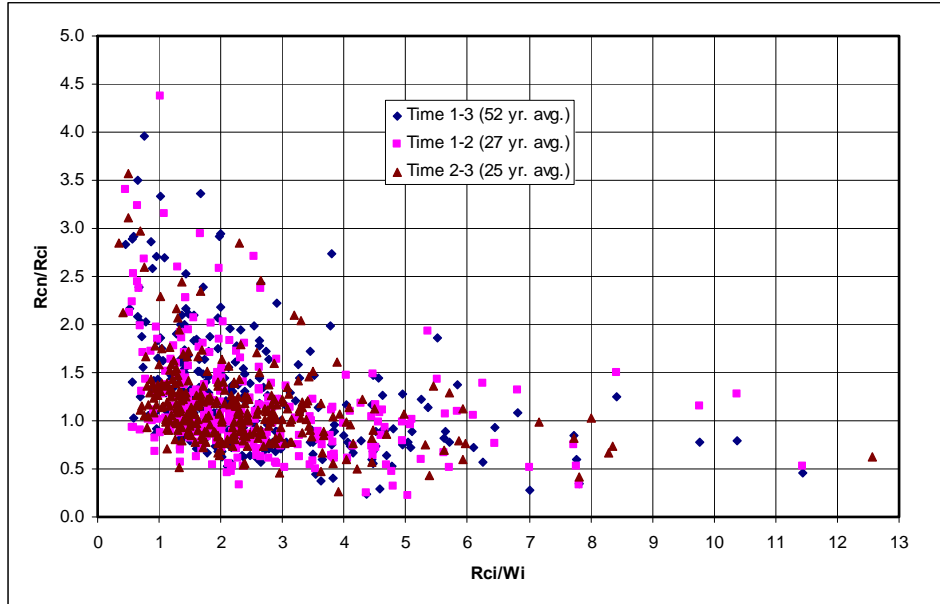

Figure 18. Change in Radius of Curvature versus Radius of Curvature/Width (C Sites).

Frequency Analysis

As an alternative to regression equations, a frequency analysis approach is suggested for predicting extension and translation. Figures 19 and 20 show the cumulative percent of extension and translation in channel widths per year. Rates of translation tend to be greater than rates of extension (bends tend to move "downstream" relative to their orientation).

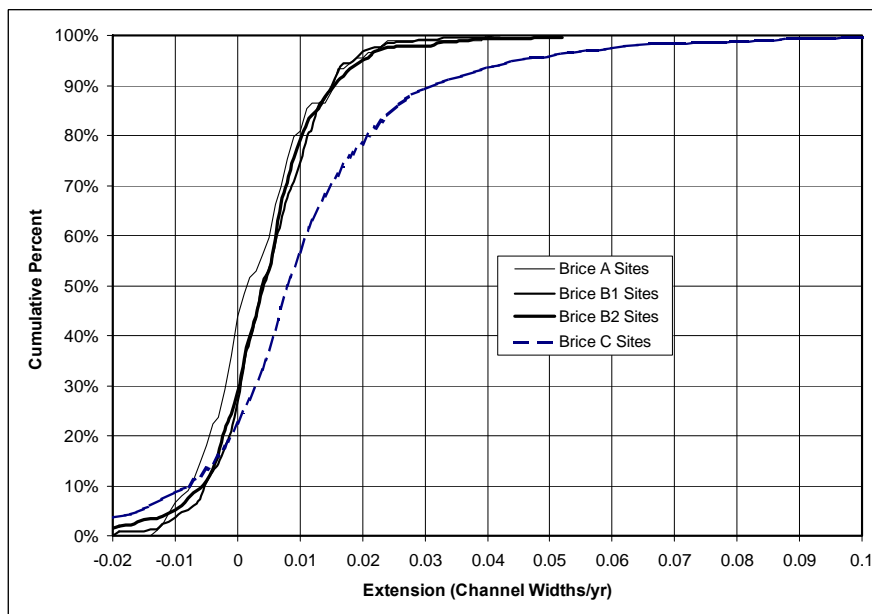

Figure 19. Cumulative percentage of extension in channel widths per year.

Using a frequency analysis approach relies on identifying the channel classification and applying a rate based on the frequency occurrence. The rates for the Brice classes and different probabilities are shown in Table 3. The cumulative percent is the probability that a bend will migrate less than the given amount. One hundred minus the cumulative percent is the chance that a bend will migrate more than that amount.

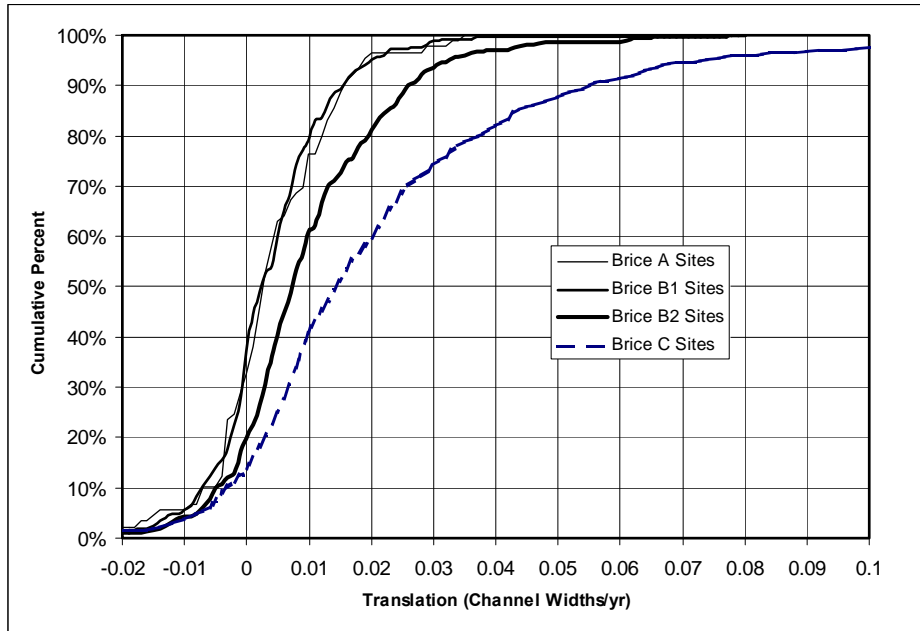

Figure 20. Cumulative percentage of translation in channel widths per year.

Table 3. Rates of Extension and Translation.								
	Extension (channel widths/yr)				Translation (channel widths/yr)			
Cum. %	50	75	90	95	50	75	90	95
A Sites	0.0015	0.008	0.015	0.018	0.0025	0.010	0.015	0.019
B1 Sites	0.004	0.010	0.015	0.026	0.0023	0.009	0.016	0.020
B2 Sites	0.004	0.009	0.016	0.020	0.007	0.016	0.026	0.033
C Sites	0.008	0.018	0.032	0.045	0.015	0.031	0.055	.074

Another way of assessing channel migration is to use the probabilities to predict the length of time for the channel to migrate one channel width. This is shown in Table 4 and is computed as one divided by the vector sum of the extension and translation rates. From Table 4, there is a 25 percent chance that an A site will require less than 78 years to migrate one channel width and a 75 percent probability that it will require more than 78 years. At the other extreme, a C site has a 50 percent chance that it will migrate one channel width (mostly translation) in 59 years and a 25 percent chance that it will migrate one channel width in only 28 years. These results are another clear indication that screening for relatively stable sites and classification are valuable aspects of evaluating channel migration potential.

Table 4. Years to Migrate One Channel Width.				
Percent Chance	50	25	10	5
	Years to migrate one channel width			
A Sites	343	78	47	38
B1 Sites	217	74	46	30
B2 Sites	124	54	33	26
C Sites	59	28	16	7

Figure 21 is an illustration of the frequency analysis approach applied to an A and C site assuming a similar starting condition. For the initial condition both banklines are shown and for a 30 year future condition several potential channel locations (outer bank only) are shown. The radius is approximately 3 times the width so expansion is assumed to be zero. At the 50 percent level the A site shows almost no migration while the C site shows the potential to migrate half the channel width. At the more extreme percentage, there is a 10 percent chance that the A site will migrate half a channel width in 30 years and that the C site will migrate nearly two channel widths. As an alternative to photo comparison or as a check on the results of the photo comparison, this frequency analysis approach provides reasonable results. However, it should only be considered as an alternative to photo comparison when no data is available for the extrapolation technique using photo comparison.

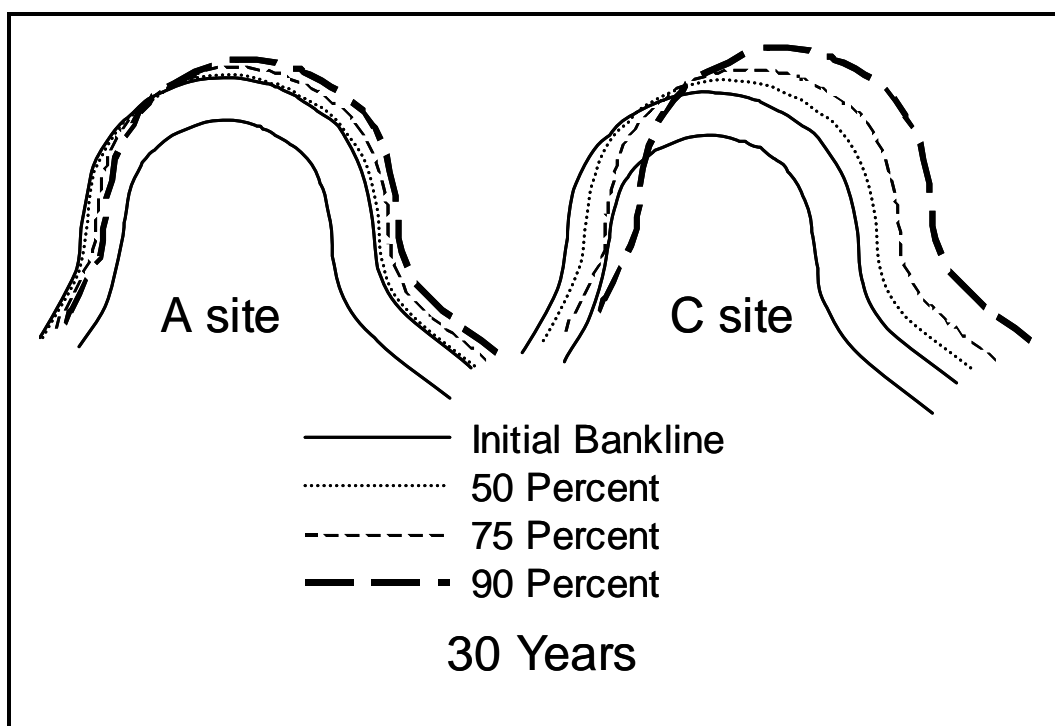

Figure 21. Example movement frequencies.

In applying the frequency analysis approach, one could plot the 50 percent migration potential. If this amount would cause a problem for the structure, some countermeasure would be warranted. If this amount of migration potential would not cause a problem, but one of the lower probability amounts of migration would, then, depending on the structure, an action ranging from a constructed countermeasure to monitoring may be warranted. If even the most extreme migration would not cause a problem, then only monitoring may be warranted.

Summary

The statistical analyses support the following conclusions:

- The classification procedure to segment meander data (Figure 11), and screening equiwidth sites (A and B₁, classes) as low priority for impact on infrastructure are valid.
- The frequency approach (for extension and translation) is intended, primarily, as a back-up approach. The most reliable prediction of channel migration can be made using the photo comparison techniques in the Handbook.
- Applying standard regression techniques to predicting meander migration directly did not yield statistically significant relationships.

THE HANDBOOK

Overview

The principal product of this research was a stand-alone Handbook for predicting stream meander migration using aerial photographs and maps. The Handbook deals specifically with the problem of incremental channel shift and provides a methodology for predicting the rate and extent of lateral channel shifting and down valley migration of meanders. The methodology is based, primarily, on the analysis of bend movement using map and aerial photo comparison techniques; but frequency analysis results are provided (see Regression Analysis) to supplement the comparative analysis. The methodology enables practicing engineers to evaluate the potential for adverse impacts due to incremental meander migration over the design life of a bridge or highway river crossing and ascertain the need for countermeasures to protect the bridge from any associated hazards.

This section summarizes the content, methodology, and approach of the Handbook. Chapter 3 provides interpretation and appraisal of the Handbook methodologies, results of testing and evaluation by the Research Team, and Beta testing by State DOTs. The Handbook covers the following topics:

- Screening and classification of meander sites
- Sources of mapping and aerial photographic data
- Basic principles and theory of aerial photograph comparison
- Manual overlay techniques
- Computer assisted techniques
- GIS-based measurement and extrapolation techniques

- Frequency analysis
- Sources of error and limitations
- Illustrated examples and applications using manual overlay techniques

Chapter 1 provides an introduction to the Handbook and a discussion of a range of potential applications of the techniques described in the Handbook. Chapter 2 describes the basic principles and processes of stream channel meander migration and discusses the potential hazards caused by meander migration as well as by avulsions and cutoffs.

Chapter 3 presents a geomorphic classification scheme, modified from the channel pattern classification originally developed by Brice (72), as an approach for both screening and classification. The most common river types (or meander modes) likely to be encountered by hydraulic engineers in the field are addressed by this classification. The screening procedure to identify *stable* meandering stream reaches ensures that engineering and inspection resources are not allocated to locations where there is little probability of a problem developing.

The basic principles of photogrammetry, the types and sources of aerial photography, and the application of aerial photography to meander migration analysis are discussed in Chapter 4.

Chapter 5 describes a manual overlay technique that uses historic bankline positions acquired from sequential historic maps and aerial photos to assess historic channel position. By inscribing and tracking the movement of circles of known radius on a bend over time, a prediction can be made on the probable position of the bend at some point in the future. The chapter provides information on using three ways to apply the overlay technique including: (1) a manual method, (2) the use of computer assisted methods, and (3) the use of the ArcView-based Bend Measurement and Channel Migration Predictor tools developed for use with the Handbook.

The potential sources of error and limitations associated with the use of historic aerial photographs and maps in conducting a meander migration assessment and prediction are described in Chapter 6.

A detailed description of manual, computer assisted, and GIS-based methodologies using map and aerial photo comparison techniques to conduct the overlay and prediction of meander migration over time is provided in Chapter 7. The GIS-based measurement and extrapolation tools are included on CD-ROM at the back of the Handbook. The use of the frequency analysis results to assist in accurately predicting meander migration is described as well.

Chapter 8 provides detailed, step-by-step examples of assessing historic meander migration and predicting future meander development using the methodologies described in the previous chapters.

Appendix A of the Handbook describes how to download TerraServer images from the Internet for use in the analysis and prediction of meander migration. Methods for delineating the bankline of a channel and determining the radius of a meander bend are provided in Appendix B. Instructions on installing the ArcView-based Data Logger and Channel Migration Predictor tools are provided in Appendix C. Tips for delineating banklines from historic aerial photos that

are not georeferenced for use with the Channel Migration Predictor can be found in Appendix D. A glossary of terms used in the Handbook is provided in Appendix F.

Application of Photogrammetry to Meander Migration Analysis

The most accurate means of measuring changes in channel geometry and lateral position is through repetitive surveys of channel cross sections referenced to fixed monuments. However, this data is rarely available. A relatively simple and accurate method of determining migration rate and direction is through the comparison of sequential historical aerial photography (photos), maps, and topographic surveys.

The first major use of photogrammetry in the evaluation of fluvial systems was conducted on the Mississippi River Valley. Fisk (58) used maps, aerial photographs, and ground investigations to document historic and pre-historic Mississippi River channel patterns in the lower Mississippi River Valley. Brice (72) developed his classification system of alluvial rivers by analyzing the planform properties of 200 river reaches from topographic maps and aerial photos in order to correlate aspects of river behavior, such as rate of lateral erosion and depth of scour, with river type. From this, he developed a comprehensive methodology for conducting a stream stability and meander migration assessment using a comparative analysis of aerial photos, maps, and channel surveys (49).

Since Fisk's work, numerous researchers have used photogrammetry to document channel planform changes, erosion and sedimentation patterns, and meander migration rates on a wide variety of streams in geographically diverse regions. For example, Hooke (94, 160) used historic aerial photos and maps to document the lateral mobility of rivers in Devon, England over a 50-year period. Williams (208) used photos taken of the Platte River in Nebraska to document the spectacular reductions in channel width that have resulted from river regulation since 1900. Burkham (209) used surveys, maps, and photographs to document channel changes on the Gila River in Arizona, and Ruhe (210) used maps covering the period 1852-1970 and aerial photos from 1925-1966 to document changes of the Otoe bend on the Missouri River. Using historic maps and aerial photographs, WET (211, 212) conducted a geomorphic analysis of more than 100 miles of the Sacramento River in California. Migration rates for specific bends, a bend evolution model, and a bend cutoff index were developed to identify critical sites requiring bank protection and sites where the potential for cutoffs was high (see Literature Review).

Map and Aerial Photography Sources

Historical and contemporary aerial photos and maps can be obtained inexpensively from a number of Federal, State, and local agencies. Table 5 lists some of the main sources. The Internet provides numerous sites with links to data resources and sites having searchable data bases pertaining to maps and aerial photography. Often, just typing in a few key words relative to aerial photos or maps for a particular site into a search engine will generate a large number of links to related web sites, which can then be evaluated by the user. It is this ready availability of aerial photography resources that makes the methodologies presented in the Handbook powerful and practical tools for predicting meander migration.

Table 5. Sources of Contemporary and Historical Aerial Photographs and Maps.		
Source	Internet Address	Comments
Microsoft TerraServer – USA	terraserver.microsoft.com	Free downloads of contemporary digital topographic and aerial photo files. Operated by MSN in conjunction with Compaq and USGS
USGS EROS Data Center Sioux Falls, South Dakota	<u>Photo Finder:</u> edcwww.cr.usgs.gov/Webglis/glisbin/finder_main.pl?dataset_name=NAPP <u>Map Finder:</u> edc.usgs.gov/Webglis/glisbin/finder_main.pl?dataset_name=MAPS_LARGE	Operated by the USGS. Interactive data base search for historic and contemporary topographic maps and aerial photos.
USDA Farm Service Agency Aerial Photo Field Office (FSA - APFO) Salt Lake City, Utah	www.apfo.usda.gov/filmcatalog.html	Operated by the Farm Service Agency. Catalog of historic and contemporary aerial photos for much of the United States. Sources include SCS (NRCS), Forest Service, BLM, Park Service, and other government Agencies.
USGS Special Collections Library Denver, Colorado Reston, Virginia	library.usgs.gov/specoll.html	<i>Field Records Collection</i> is an archive of historic records including maps and aerial photography collected by USGS scientists dating back to 1879. <i>Map Collections</i> includes topographic maps for all states dating back to early 1880s.
National Archives and Records Administration (NARA) - Cartographic and Architectural Records Washington D.C.	www.nara.gov/publications/leaflets/gil26.html#aerial2	Archive of historic maps and pre-1941 aerial photos
Western Association of Map Libraries (WAML) San Diego, California	www.waml.org/wmlpubs.html	References to information on obscure historic maps and where they can be found for reproduction
U.S. Army Corps of Engineers	www.usace.army.mil	Corps Districts often have a wealth of historic photos, maps, and survey data.

Extensive topographic map coverage of the United States at a variety of scales can be obtained from the local or regional offices of the U.S. Geological Survey (USGS). In general, both aerial photos and maps are required to perform a comprehensive and relatively accurate meander migration assessment. Since the scale of aerial photography is often approximate, contemporary maps are usually needed to accurately determine the true scale of unrectified aerial photos.

Geo-referenced and rectified maps and aerial photos are the most desirable for use in the analysis of meander migration, but often can be expensive to obtain. Presently, aerial photos for the 1990s for most areas of the United States can be obtained from three major sources, the MSN TerraServer World Wide Web site, the USDA Farm Service Agency, and the U.S. Geological Survey (Table 5).

A major source of 1990s aerial photos available to the public is the TerraServer Web site operated by Microsoft Corporation. TerraServer, in partnership with the USGS and Compaq, provides free public access to a vast data store of maps and aerial photographs of the United States. Aerial photos and topographic maps at a wide variety of resolutions can be downloaded free of charge from the TerraServer Web site. The advantages of the TerraServer images are that they are rectified, geo-referenced, and are in digital format so that they are easily manipulated by a wide variety of software and can be used in GIS applications.

For sites where TerraServer photographic coverage from the 1990s is unavailable, aerial photos can be ordered from the USGS Earth Resources Observation System (EROS) Data Center in Sioux Falls, South Dakota, or from the USDA Farm Service Agency Aerial Photo Field Office (APFO) in Salt Lake City, Utah. Both agencies have World Wide Web sites (Table 5) with searchable catalogs of available contemporary and historic aerial photography.

Aerial photographs from the EROS Data Center that were flown in the 1980s and 1990s are usually part of the National Aerial Photography Program (NAPP) or the National High Altitude Photography Program (NHAP) and are at scales of 1:40,000 (1 in = 3,333 ft) or 1:60,000 (1 in = 5,000 ft). Because of the scale of these photos, small objects may be difficult to see, the resolution of enlarged portions may be poor, and measurements made from the photos may be inaccurate. Historic aerial photos ordered from EROS or from APFO range in scale from 1:5,000 to 1:40,000 with most flights having optimal scales of 1:20,000 or 1:24,000. Although both agencies have the ability to enlarge any photo to specification, some resolution is lost with increasing enlargement.

Topographic maps in paper or electronic format can be obtained from a variety of sources. Paper copies of topographic maps can be obtained from the USGS or any commercial map supplier. Digital maps (DRGs, DEMs) can be downloaded free from the EROS Web site or purchased from commercial suppliers as well. Most digital maps are geo-referenced and can be loaded directly into GIS-based applications. Portions of geo-referenced topographic maps can be downloaded free from the TerraServer web site and pieced together to form a complete map of a given area or used to fill in gaps. The Handbook cautions that care should be taken when using digital maps and photos because the geo-referenced coordinates and dimensions are usually in metric (SI) units while the contours and spot elevations shown on the maps may be in English units.

Map and Aerial Photo Comparison Techniques

A large number of geographic features and geomorphic planform characteristics used in the evaluation of meander migration are readily discernible on aerial photographs and topographic maps. Thus, a comparison of many of these features and characteristics over time can be made to determine the rate and extent of historic changes and assess potential future changes. The Handbook deals with assessments using aerial photos, but the same methods can be used when making assessments or measurements from maps.

Manual Overlay Techniques

An easy and relatively accurate method of determining migration rates and direction is through the comparison of sequential historical aerial photography, maps, and surveys. Accuracy in such an analysis is greatly dependent on the time intervals over which migration is evaluated, the amount and magnitude of internal and external perturbations forced on the system over time, and the number and quality of sequential aerial photos and maps. Major changes in watershed characteristics and hydrologic conditions can have a profound effect on meander migration patterns and rates.

An analysis of long-term changes can be useful on a channel that has coverage consisting of data sets (aerial photos, maps, and surveys) that cover multiple time intervals over a long period of time (several tens of years to more than 100 years). Long-term changes can be documented and changing migration rates can be evaluated with regard to changes in watershed characteristics and hydrology over time.

If only two or three data sets covering a short time period (several years to a few tens of years) are available, a short-term analysis may be conducted. A short-term analysis covering recent data can provide information on existing migration rates and conditions. Predictions of migration for channels that have been extensively modified or have undergone major adjustments attributable to extensive land use changes will be much less reliable than those made for channels in relatively stable watersheds.

The manual overlay technique consists of overlaying channel banklines or centerlines traced from successive historic maps or photos that have been registered to one another on a base map or photo. The first requirement of conducting a simple overlay technique is obtaining the necessary aerial photos and maps for the period of observation. The amount of detail available for analysis increases as the length of time between successive maps or photos decreases. However, a longer period of record for comparison will tend to "average out" anomalies in the record and provide a better basis for predicting meander migration by extrapolation. Abrupt changes in migration rate and major position shifts can often be accounted for by analyzing maps and photos for land use changes, and nearby stream gage records can be examined for extreme flow events.

Although most photos come with an optimal scale (e.g., 1:20,000), the scale is not always accurate for the purposes of analysis. The scale problem can be overcome through the use of multiple distance measurements taken between common reference points on a photograph and related base map. Measurements of distance for several reference-point pairs common to both the photo and the map are then averaged to define a relatively accurate approximation of the

scale of the photos. Common reference points can include constructed features such as building corners, roads, fence posts and intersections, irrigation channels and canals, or natural features such as isolated rock outcrops, large boulders, trees, drainage intersections, stream confluences, and the irregular boundaries of water bodies. The following relationship is used to determine the scale of the aerial photo relative to the base scale of the base map or photo:

$$\frac{\text{Length Between Aerial Photo Reference Points}}{\text{Length Between Same Reference Points on Base}} \times \text{Base Scale} = \text{Aerial Photo Scale}$$

Once the scale of each historic aerial photo is estimated, the photo can be enlarged or reduced to the scale of the base, whether it is another photo or a map. This can be done using a copier with a reduction or enlargement mode or using a flatbed scanner. With photos at a common scale, successive bankline or centerline positions can be determined.

Accurate delineation of a bankline on an aerial photo is dependent primarily on vegetation density at the top of the bank. The bank top is most easily defined if stereopairs of photos are available, but individual photos can also be used when evaluated by experienced personnel. A detailed discussion of the methods for delineating a bankline is provided in Appendix B of the Handbook.

After the maps and photos have been enlarged or reduced to a common scale, common reference points have been identified, and the banklines or centerlines have been delineated, the banklines or centerlines are then overlain on each other by matching the common reference points. The overlain bankline or centerline positions can then be evaluated with regard to migration distance, rate, and direction over time. Using the information and data obtained from this type of analysis, predictions can then be made on the potential position of the river at some point in the future. A step-by-step example of the application of the overlay prediction technique is presented in Chapter 3.

Computer Supported Techniques

The availability of powerful computers and photo editing software provides an alternative approach for performing the photo comparison techniques discussed in the previous section. For example, photo comparison and prediction can take advantage of the photo editing capabilities in Microsoft Word or PowerPoint. These features were used to develop the illustrative examples provided in Chapters 7 and 8 of the Handbook.

In addition, computer aided design and drawing (CADD) software, such as AutoCAD and Bentley's MicroStation, and GIS-based software, such as ArcView and ArcInfo, can be used in conjunction with a flatbed scanner and digitizing tablet to perform the photo comparisons with greater precision and accuracy, especially when the maps and photos are geo-referenced. Where digital files of aerial photographs are unavailable, a flatbed scanner can be used to scan aerial photographs to a relatively high resolution. Software that can manipulate a photographic image, such as MicroStation Descartes, can be used to warp a scanned aerial photograph to fit a map or another resolved aerial photo. A digitizing tablet can be used to record the registration points and bankline positions, as well as other features from historical aerial photographs, directly onto a geo-referenced drawing, map, or photo.

The photos and banklines can also be geo-referenced and the associated data can be imported into a GIS. For example, for the data collection effort for this project, the bend characteristics and meander migration patterns for more than 1,500 bends on numerous rivers distributed across the continental United States were recorded using a digitizing tablet in conjunction with Bentley's MicroStation (see discussion of Archive Data Base). The acquired data was used to develop the GIS-based photogrammetric comparison methods to predict the rate and direction of bend migration outlined in the next section.

GIS-Based Measurement and Extrapolation Techniques

ArcView is a GIS and mapping software package developed by Environmental Systems Research Institute Inc. (ESRI). An ArcView extension, the **Data Logger**, is a GIS-based, menu-driven circle template methodology that was developed for NCHRP Project 24-16 to streamline the measurement and analysis of bend migration data and aid in predicting channel migration. The **Channel Migration Predictor** is another ArcView extension that was developed for this project using the extrapolation techniques described in more detail in Chapter 3. Both extensions were developed using ArcView Version 3.2.

The Predictor tool uses the data archived by the Data Logger in predicting the probable magnitude and direction of bend migration at some specified time in the future. The Data Logger and the Channel Migration Predictor are ArcView extensions that were created using Avenue, a programming language and development environment that is part of the ArcView software package. Avenue is used to create specialized graphical user interfaces and to run scripts that customize the functionality of ArcView.

An ArcView project is a file used to store the work done with ArcView on a particular application, such as recording river bankline data. An ArcView project file contains all the views, tables, charts, themes, and scripts associated with an application.

Both the Data Logger and the Channel Migration Predictor consist of a set of ArcView scripts. A script is the component of an ArcView project that contains Avenue code. Just like macros, procedures, or scripts in other programming or scripting languages, ArcView scripts are used to automate tasks and add new capabilities to ArcView.

The Data Logger provides users with a quick and easy way to gather and archive river planform data. The physical banklines are represented by one or more ArcView themes. A theme is a set of geographic features in a view. A view is an interactive map that allows the user to display, explore, query and analyze geographic data in ArcView. The bend delineation points for each bend and each historical record are archived in individual themes to provide a graphical record of the user's interpretation of each bend. For each river bend and each historical record, the Data Logger records various river characteristics (e.g., bend radius, bend centroid, river widths, bend wavelength, etc.). This data is organized by river reach and recorded in a table identified by the reach name. These tables provide a permanent record of several river planform characteristics that can be further studied using the Channel Migration Predictor or various statistical procedures.

The Channel Migration Predictor examines a table of river reach data for several bends and two or three historical records per bend and then calculates rates of change in bend radius and bend center position. This rate data allows the Channel Migration Predictor to estimate the location of a bend at user specified times. As discussed above, river reach data tables can be created using the Data Logger. Users can also create tables for input to the Channel Migration Predictor in the form of properly formatted data base files using other means, such as Excel or Avenue.

Data logging and prediction require the following steps to be performed at each bend for each historical record:

1. Locate the bankline delineation points on the outside of a river bend.
2. Inscribe an arc of a circle over the demarcation points to describe the radius and orientation of the bend.
3. Estimate the channel widths at the apex of the bend and at the upstream and downstream crossings (ends of the bend).
4. Estimate the wavelength and amplitude of the bend.
5. Use consecutive historical records and the data collected in steps 1-3 to estimate the extension and translation rates for a bend.
6. Use the migration and extension rates to extrapolate and estimate the future bankline locations.

Instructions on installing the ArcView-based Data Logger and Channel Migration Predictor are provided in Appendix C of the Handbook. Examples using these tools to conduct planform measurements and meander migration prediction are provided in Chapter 8 of the Handbook.

ARCHIVE DATA BASE

Overview

Another stand-alone deliverable for this project was an archive of the data base compiled on CD-ROM to include all meander site data acquired for this study. With this archive data set, future researchers will have a readily accessible data base in a very useable format for a variety of studies. These studies could include additional empirical analyses and more complex regressions based on the archive data. The Brice data alone is an invaluable resource for future researchers, as it includes the field measurements compiled by the U.S. Army Corps of Engineers Waterways Experiment Station for their study of stable channel design.

Although the Panel suggested developing a relational data base for the archive, this effort proved to be beyond the scope and budget available for the following reasons:

- Size of the data base with 141 meander sites, containing 1,503 meander bends
- Size of the files required to archive base quad sheets, mapping, and photography
- Multiple file formats for the data (e.g., MicroStation files, JPEG, TIFF, and Excel files)
- For ease of use, files are distributed in different subdirectories; however, this makes developing hyperlinks for related files a complex and time consuming process

The Excel spreadsheet format adopted for the data base permits cross-referencing based on data source, meander class, river name, or State. This provides a simple and useable approach to searching the data base. The spread sheets to search the data base by these four categories are shown in Appendix B. The data collection and measurement procedures used to develop the data base are described in detail in Chapter 3. The CDs containing the archived data base compiled for this project were provided to TRB/NCHRP with this report. A paper copy of the data spread sheets was also submitted on acid-free paper for permanent archiving by TRB.

Data Base Structure

The hierarchy for the distribution of the sites and accompanying data included in the data base is shown in Figure 22.

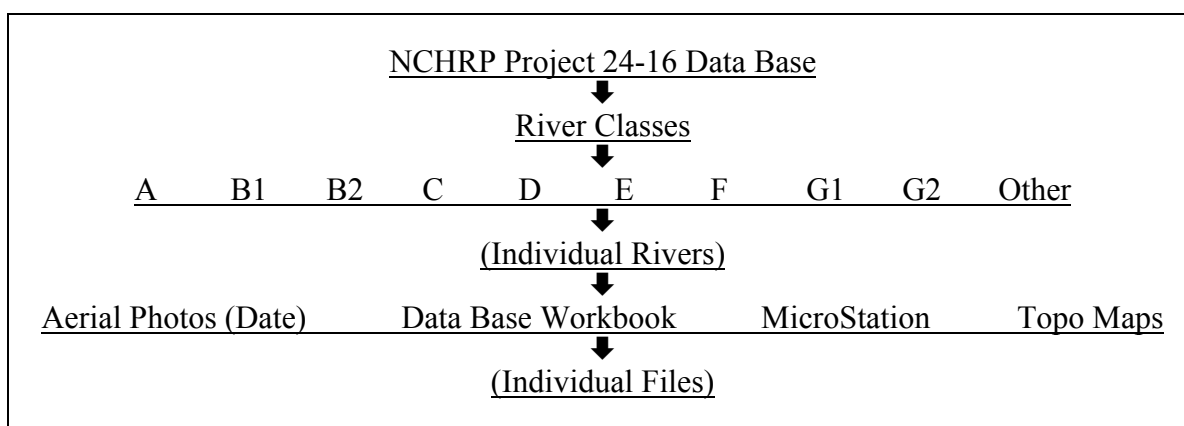

Figure 22. Hierarchy for Archive Data Base

Figure 23 shows an example of how the directory structure appears on the CDs. As noted above, included under the main directory is an Excel workbook file that includes four spreadsheets that cross-reference each data site by the (1) source of the data, (2) modified stream classification, (3) river name, and (4) state in which the site is located (see Appendix B). A Word document included in the main directory briefly describes each of the file types included in the data base. An ASCII text file is also included that provides the color key for the historic channel position sheets for the various Kansas rivers included in the data base (see Chapter 3, Data Collection).

The data for each meander site is compiled in Microsoft Excel workbooks. There are multiple spreadsheets within each of the workbooks. The first spreadsheet, designated General Data, contains the general information compiled by various sources and an aerial photo showing the site limits and the included meander bends (Figure 24). Each meander bend is numbered from upstream to downstream. There are individual spreadsheets, designated by the bend number, which contain detailed historic data for each of the bends of the site (Figure 25). There is also a spreadsheet, designated Discharge Data, that has the mean daily and annual peak discharge data for the gage nearest to the site. Finally, a summary spreadsheet contains all the measured data for all the bends of the site.

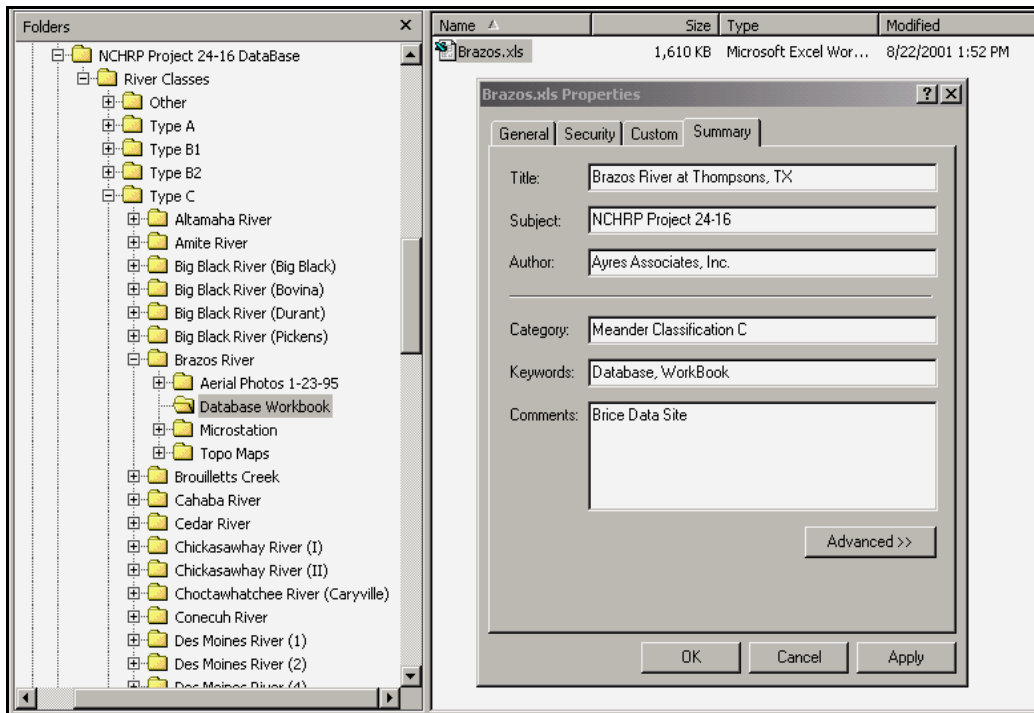

Figure 23. Example directory for the Archive Data Base.

Summary

The CD-ROM archives contain the Excel workbooks, MicroStation files, 1990s and historic (where applicable) aerial photos, and the topographic maps for each site in digital file format. The data base includes 141 meander sites containing 1,503 meander bends on 89 rivers in the U.S. The maps and photos are in JPEG format. The files are sorted by stream class and river name with subdirectories for the workbooks, maps, photos, and MicroStation files. Within the archived data base there is a text file that provides a cross-reference between the data source and the stream class and location.

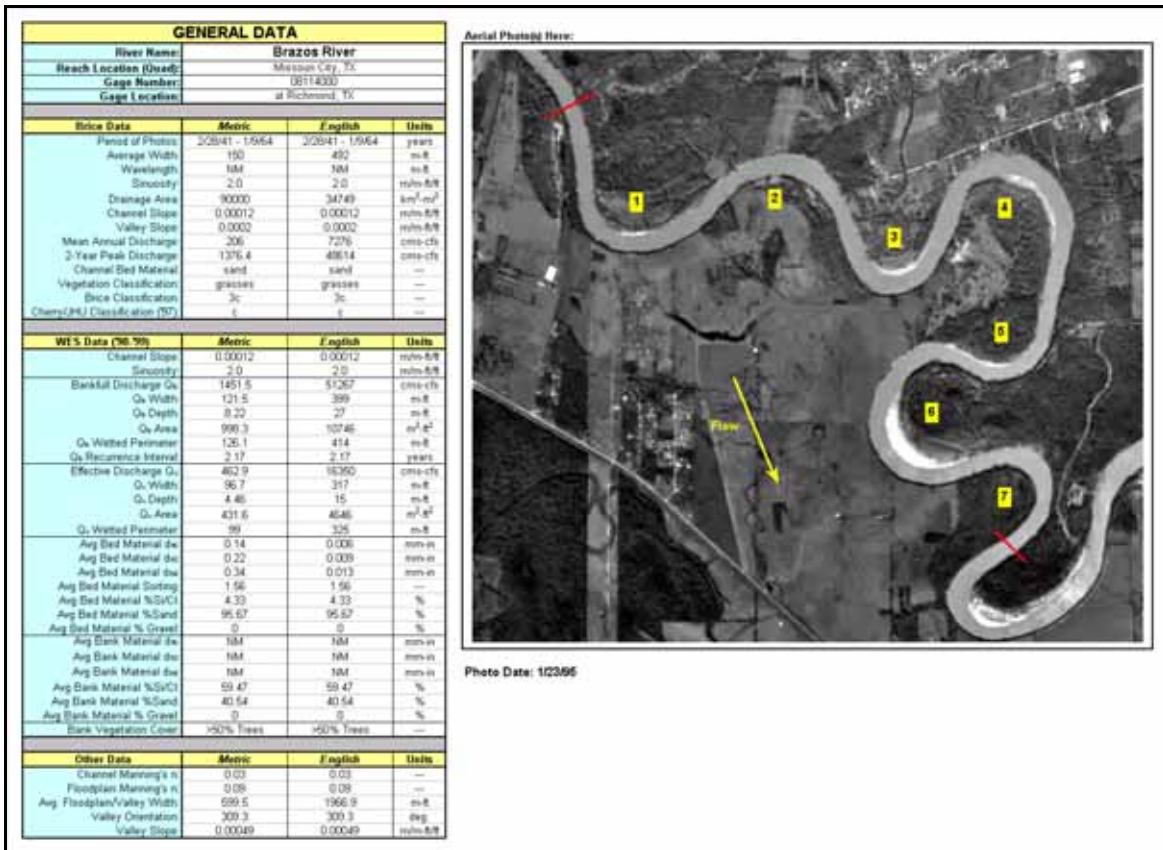

Figure 24. General Data spreadsheet containing the existing data and aerial photograph with bend locations for a site on the Brazos River, Texas.

Brazos River									
BEND #5									
(Each bend has a separate worksheet in this workbook)									
	Location:		at Thompsons, TX						
	USGS 7.5' Quad Name:		Missouri City, TX						
	Nearest Gage Name and Number:		at Richmond, TX			08114000			
	SITE CLASSIFICATION								
	Flow Habit:		PERENNIAL						
	River Classification:		C						
	Sediment Load Type:		Mixed Load						
Brice Bend Type:		Simple Symmetrical							
Group	Variable	English Value			Units	Metric Value			Units
		1941	1964	1996		1941	1964	1996	
Planform	Outside Bank Avg. Radius of Curvature	1063	1192	1277	feet	324.0	363.4	389.4	meter
	Right or Left Hand Bend	L	L	L	---	L	L	L	---
	Center Point of Bend - Northing	10723107	10722996	10722950	feet	3268410	3268376	3268362	meter
	Center Point of Bend - Easting	818133	819039	817937	feet	249367	249339	249308	meter
	Valley Orientation	309.3	309.3	309.3	deg.	309.3	309.3	309.3	deg.
	Bend Orientation	307.6	292.9	289.4	deg.	307.6	292.9	289.4	deg.
	Channel Sinuosity	1.60	1.69	1.80	ft/ft	1.60	1.69	1.80	m/m
	Meander Wavelength	5176	6491	5475	feet	1577.8	1978.6	1668.9	meter
	Meander Amplitude	1240	1507	1197	feet	377.9	459.3	364.9	meter
Geometry	Channel Width at Crossing	452	446	417	feet	137.7	136.0	127.1	meter
	Channel Width at Bend Apex	512	751	436	feet	156.0	228.9	132.8	meter
	Channel Hydraulic Depth at Crossing	27	27	27	feet	8.2	8.2	8.2	meter
	Maximum Channel Depth at Bend Apex	NM	NM	NM	feet	NM	NM	NM	meter
	Crossing Width/Depth Ratio	16.8	16.5	15.5	ft/ft	16.8	16.5	15.5	m/m
	Maximum Point Bar Width in Bend	0.0	0.0	107.3	feet	0.0	0.0	32.7	meter
	Average Floodplain Width	1967	1967	1967	feet	599.5	599.5	599.5	meter
Slope	Channel Slope	0.00030	0.00029	0.00027	ft/ft	0.00030	0.00029	0.00027	m/m
	Valley Slope	0.00049	0.00049	0.00049	ft/ft	0.00049	0.00049	0.00049	m/m
Roughness	Estimated Channel Manning's n	0.03	0.03	0.03	---	0.03	0.03	0.03	---
	Estimated Floodplain Manning's n	0.09	0.09	0.09	---	0.09	0.09	0.09	---
Sediment	Bed Material D50	0.009	0.009	0.009	in	0.2	0.2	0.2	mm
	Bed Material % Si/Cl	4.33	4.33	4.33	%	4.33	4.33	4.33	%
	Bank Toe Material D50	NM	NM	NM	in	NM	NM	NM	mm
	Bank Toe Material % Si/Cl	59.47	59.47	59.47	%	59.47	59.47	59.47	%
Riparian Veg	Percent Vegetation Cover	NM	NM	>50% T	%	NM	NM	>50% T	%
	Root Depth as Percent of Bank Height	19	19	19	%	19	19	19	%
Discharge Data	Mean Annual Discharge	7882	8624	7854	cfs	223.2	187.6	222.4	cms
	Average Peak Discharge	66057	51268	54265	cfs	1870.7	1451.9	1536.8	cms
	Bankfull Discharge	---	---	51267	cfs	---	---	1451.9	cms
	Effective Discharge	---	---	16350	cfs	---	---	463.0	cms
REACH LIST									
Vegetation Types:									
Dense trees, swampland, and farming									
*Activity Indicators:									
Old oxbows in floodplain; farming to edge of channel (vertical eroding banks) along most of right bank									
Upstream Controls:									
Flows regulated since 1941 by upstream reservoirs, floodwater-retarding structures, and irrigation diversions.									
Downstream Controls:									
0									
*Activity Indicators (e.g. ridges and swales, neck cutoffs, chute cutoffs, recently abandoned meander bends, farming to edge of channel, crevasse splays, etc.) NM = Not Measured or No Data									

Figure 25. Bend spreadsheet containing measured and existing data for a bend on the Brazos River, Texas.

CHAPTER 3

INTERPRETATION, APPRAISAL, APPLICATION

OVERVIEW

This chapter presents interpretation, appraisal, and applications of the methodologies for predicting the rate and extent of channel meander migration presented in the Handbook. While several topics are extracted from the Handbook, much of this information was not necessary for the Handbook and appears only in this Final Report.

The step-by-step illustration of the manual overlay and prediction technique is taken from Section 7 of the Handbook. It is presented here to provide the reader of this Final Report a better understanding of the methodology and of the capabilities and limitations of the aerial photograph comparison techniques. Additional interpretation and appraisal of classification and screening, regression analysis, and frequency analysis, which are summarized in the findings of Chapter 2, are also included. Details of the data collection effort, concepts (and assumptions) applicable to measuring meander migration, and appraisal of the results of testing the GIS predictor and State DOT testing of the methodologies are presented in this chapter. Finally, the implementation plan for the Handbook is developed.

DATA COLLECTION

Existing data was collected from a variety of sources and researchers. The data set compiled encompasses rivers in 23 states across the United States. The primary data upon which much of this project is based comes from work conducted by Brice (72). The Brice data used for this project consists of 811 bends at 82 sites on 59 rivers. Eight additional data sets containing 692 bends at 59 sites on 30 rivers were acquired from other sources.

The Brice bankline tracings are based on aerial photography flown primarily in the late-1930s to early-1940s and the mid-1960s to early-1970s. Attempts were made to acquire historic aerial photography from various agencies taken in the 1930s and 1960s for the data sets that had no historic bankline comparisons. Aerial photography from the 1990s and topographic maps were acquired for all the data sets. The 1990s photos and topographic maps were either downloaded from sites on the Internet or ordered from various agencies. All the photography and maps for each site were overlain, registered, and geo-referenced, and are compiled into a data base for future use. Updated discharge data was also obtained for each of the sites used in this project.

The data sets are composed of data that is both specific and general in nature. Data measured as part of this project is site or bend specific. The general data acquired from the various sources was obtained at gaging stations or is associated with river reaches that may or may not be in close proximity to the study reaches. Therefore, problems, restrictions and limitations associated with each data set are included in the following discussion.

Brice Data Set

The data set collected by Brice was part of an FHWA project to develop a simple method for determining relative stability of streams based on stream type (49). The Brice data set consists of morphometric data as well as aerial photos, maps, and bankline tracings for 200 stream reaches in the United States. The original data set is located at the U.S. Army Engineers Waterways Experiment Station (WES) in Vicksburg, Mississippi. Copies of the bankline tracings for the 82 meandering stream sites used in this project were acquired from WES.

Brice compiled the morphometric data for each of the meander sites for projects conducted in the 1970s (49, 72, 213). The data set was compiled from existing information, field investigations and surveys, gage records, maps, and aerial photos. Under a research project at Johns Hopkins University, the data set was inventoried and additional data was derived for 133 of the Brice sites by Cherry et al. (48). In 1999, field crews consisting of personnel from WES, the USGS, and the University of Nottingham, UK, visited the Brice sites and obtained survey and sediment data. The field crews obtained bed and bank samples, measured cross-sections, photographed each survey site, and estimated the percentage of vegetative cover on the tops of the banks. However, the survey and sampling efforts were confined primarily to straight channel reaches with stable banks at each of the Brice sites.

Schumm Great Plains Rivers Data Set

Schumm collected data on 90 Great Plains rivers and streams in the late-1950s and 1960s. Much of this information is compiled in USGS Professional Paper 352-B (214). Planform, cross-section, sediment, and discharge data were collected and compiled for each of the sites. The data for most of the sites were collected near bridge crossings in close proximity to gaging stations where possible.

A total of 256 bends at 20 sites on 9 rivers were selected from the Schumm Great Plains Rivers data set. The rivers and streams of the Schumm data set used in this project are located in Kansas, Nebraska, Montana, and Wyoming. Complete banklines from the early-1970s were available in an atlas compiled by the USACE Kansas City District (215) for the Kansas, Smoky Hill, Saline, and Solomon Rivers in Kansas. Aerial photographs taken in the late-1960s or early-1970s were obtained for the remaining sites. Schumm supplied the raw sediment data for the sites used in this project.

Minnesota Rivers Data Set

MacDonald et al. (216) compiled data and analyzed meander problems on several streams in Minnesota. The analysis was conducted using aerial photos and topographic maps. The data set consists of aerial photos from the 1930s through the 1980s and general morphometric, sediment, and discharge data for 16 streams. A total of 15 sites encompassing 240 bends on 13 of the 16 available streams were evaluated. The authors (216) supplied the negatives of the aerial photographs and maps and the sediment data used in their analysis. Bankfull channel width and slope were based on measurements taken on topographic maps and stream depth was synthesized using accepted methodologies. Bed sediment samples were collected and the sieve analysis results on all but two rivers were available (216).

Ayres Associates Data Set

Ayres Associates compiled a complete data set for both the middle Sacramento River (211, 212) in California and the lower Alabama River in Alabama (217). Bankline tracings of 25 bends of the Sacramento River from the 1930s and 1960s were compiled from an atlas of meander migration of the river from 1896 and 1981 (218), aerial photography, historic surveys, and maps. A detailed data set on a large part of the Sacramento River system was compiled as a result of work for the USACE Sacramento District since 1986. The detailed data and bankline comparisons for 17 bends on the Alabama River were compiled as the result of a project conducted for the USACE Mobile District in 1986.

Other Data Sets

Additional data was obtained for the Des Moines, Genesee, Powder, and Carson Rivers. Data was compiled on 34 bends of the Des Moines River downstream of Red Rock Reservoir in Iowa from bank erosion studies conducted by Odgaard (219) and the USACE Rock Island District (220). Mussetter Engineering, Inc. (221) provided detailed data on a reach of the Genesee River that includes 10 bends downstream of Mount Morris Dam near Geneseo, New York. Banklines from the 1930s and 1960s and morphometric data for 59 bends at 6 sites on the Powder River between Moorehead and Broadus, Montana were obtained from Martinson and Meade (102) and Martinson (127). The Nevada Department of Transportation provided historic aerial photographs and morphometric data for 6 bends on the Carson River near Weeks, Nevada.

Acquisition of Updated Aerial Photos, Maps, and Discharge Data

Aerial photos from the 1990s for all of the sites were obtained from three different sources. The first and primary source of 1990s aerial photos is the TerraServer web site operated by Microsoft Corporation (see Table 5). TerraServer, in partnership with the USGS and Compaq, provides free public access to a vast data store of maps and aerial photographs of the United States. Aerial photos and topographic maps at a wide variety of resolutions for most of the meander sites were downloaded free of charge from the TerraServer Web site. For those sites where no photographic coverage was available from TerraServer, 1990s aerial photos were ordered from either the USGS Earth Resources Observation System (EROS) Data Center in Sioux Falls, South Dakota, or from the USDA Farm Service Agency (FSA) Aerial Photo Field Office (APFO) in Salt Lake City, Utah. Both agencies have Web sites with searchable catalogs of available aerial photography.

Topographic maps, either in paper or electronic format, can be obtained from a variety of sources. Paper copies of topographic maps can be obtained from the USGS or any commercial map supplier. Digital maps (DRGs, DEMs) can be downloaded free from the EROS Web site or purchased from commercial suppliers as well. Most digital maps are geo-referenced and can be loaded directly into GIS-based software. Portions of geo-referenced topographic maps can be downloaded free from the TerraServer web site and pieced together to form a complete map of a given area or used to fill in gaps. Care should be taken when using digital maps and photos because the geo-referenced coordinates and dimensions are usually in metric units while the contours and spot elevations shown on the maps may be in English units.

Up-to-date discharge data was obtained, where possible, for gaging stations in close proximity to all the meander sites. Mean daily discharge and annual peak discharge data is available free from the Water Resources web site of the USGS. The web site contains a searchable data base broken down by state, county, basin, and gage number. In some cases, gage data may be available from city, county, or state-operated gages, which may or may not be available via the Internet. The operating agency may need to be contacted to obtain the data.

MEASUREMENT PROCEDURES

Historic and recent aerial photos and topographic maps were obtained for all of the meander sites used in this project. Measurements of channel and valley morphometry were then made using a common CAD package and a specially developed bend measurement tool in the form of an ArcView[®] extension.

Measurements Using MicroStation[®]

The maps and photos were scanned where necessary and then compiled and geo-referenced to each other in Bentley's MicroStation[®] based either on known UTM coordinates or on common reference points. The Brice bankline tracings were digitized using a large digitizing tablet. In addition to the banklines, reference points on the tracings that could be identified with points on the topographic maps or recent aerial photos were digitized. The tracings were then overlain with the maps and recent photos of each reach in the appropriate MicroStation[®] files.

Because of distortion in the Brice bankline tracings and unrectified aerial photos, MicroStation[®] Descartes[™] was used to "warp" the images so that common reference points matched exactly. The Brice bankline tracings of each year at a given site were registered with the topographic maps and aerial photographs of the site and saved as individual layers. Once the historic and recent aerial photographs for meander sites were registered in MicroStation[®], the banklines of the channel were digitized and saved as individual layers.

Bankline Delineation

The accurate delineation of a bankline on aerial photos is dependent primarily on the density of vegetation at the top of the bank. Where vegetation becomes increasingly dense along a bank, small sections of the top or edge of the bank may be visible such that a line can be drawn connecting the sections. Often the top of the bank may be completely obscured by vegetation and one may be required to locate the top of the bank by approximation. This can be done by assuming that the bankline does not extend beyond the middle of each tree growing at the edge of the stream and then drawing the bankline on the riverward side of the crown of the tree. Shadows and changes in shading can often delineate the crown of a tree. If the density of vegetation along a stream is such that an accurate delineation of the top of the bank cannot be made, then the use of the channel centerline may be necessary.

Brice (72) delineated the banklines for two different years at each of his sites by projecting the aerial photographs of each year onto a piece of paper and tracing the banklines on the paper. The banklines were overlain using common reference points. The scales of the

photos were estimated based on known or approximate distances between reference points. However, distortion of the photographs was a significant problem in some cases, especially with regard to the alignment of reference points on the photos from the two different time periods. In addition, dense vegetation obscured the banklines at some sites such that the bankline positions had to be estimated.

In a few instances, exact registration of the 1990s aerial photos and topographic maps with the Brice bankline tracings was not possible because most of the registration points no longer existed or were obscured by dense vegetation. In these cases, the 1990s photos were matched with the topographic maps and the banklines were overlain as closely as possible on the aerial photo using what registration points and physical features were available.

The Schumm (214) and Kansas City District COE data set consists of sites on the Kansas, Saline, Solomon, and Smoky Hill Rivers. The historic channel positions for these rivers were taken from an atlas of historic channel migration (215). It is not known if the channels are based on the waters edge under low water or high water conditions or on top bank locations. The most recent course associated with 1970s river position obscures the older courses of the river and makes the older banklines unusable. Therefore, the 1970s banklines for these sites were the only banklines used. The atlas consists of the historic banklines for each of the rivers overlain on geographic maps that were easily registered with the topographic maps and the 1990s aerial photos.

The historic (1979) banklines for the Des Moines River are based on aerial photography included as plates in the Rock Island District report on bank erosion (220). Historic banklines for the Minnesota rivers data set are based on negatives of a pair of historic aerial photos for each of the sites (216). Parker provided the negatives of the aerial photos. The historic banklines for the Sacramento River were taken from an atlas of historic banklines compiled by the California Department of Water Resources (DWR) for a salmon spawning gravel study (218). Aerial photos of the Sacramento River taken in 1978 provided the base on which the banklines were overlain in the atlas. Martinson and Meade (102) compiled the historic banklines for the Powder River on USGS 7.5-minute topographic quadrangle maps. Historical (1950s and 1960s or 1970s) and 1990s aerial photos were acquired from the USGS EROS Data Center or the USDA Aerial Photo Field Office for the remaining sites.

Valley Width and Orientation

The valley width and orientation for all sites were based on the evaluation of both topographic maps and aerial photos. Where possible, the valley margins were defined based on a significant change in contour elevations at the intersection between a well-defined valley wall and the edge of the floodplain/meander belt. The valley margins may also be defined by confining terraces or by structural features such as levees and roadway embankments, which would restrict the active migration of the river.

Lines were drawn across the valley between the valley margins and perpendicular to the general valley direction at regular intervals at each site. The valley width was determined based on the average of the cross-valley line lengths. A line was fitted to the midpoint of each of the

cross-valley lines to define the valley orientation line. Cross-valley lines and the valley orientation lines were drawn to reflect a significant change in valley direction. The valley orientation is measured counter-clockwise from a zero angle defined to be due east.

Slope and Sinuosity

The ideal method for measuring valley slope (S_v) requires at least two well-defined sequential contours crossing the valley floor perpendicular to the valley direction. The straight-line distance between these two contours generally defines the valley floor slope. However, contours rarely cross the valley floor in a perfectly straight line perpendicular to the valley direction, nor do they cross the valley floor without significant breaks or multiple changes in direction. Therefore, estimates of valley slope require either actual measurements of the valley slope or the identification of contour crossings of the channel. Valley slope can be estimated by dividing the change in elevation between contours by the measured straight-line distance between contour crossings of the channel along a line defining the general channel orientation (Figure 26A).

However, rivers rarely follow the direction of the valley exactly, but instead often wander across the valley floor. In these cases, the valley distance should be measured along a composite line that defines the trends in the river's orientation. For example, Figure 26B shows the valley slope determination based on the distance between contours as measured along a compound line defined by multiple channel trends.

Channel slope (S_c) can be obtained from surveys or by measurements taken from topographic maps. Channel slopes are obtained from maps by dividing the elevation change between successive contour crossings by the distance measured along the centerline of the river between the contour crossings. This provides the slope of the river for the date of the aerial photography used to make the map. If channel slope data is not available for other periods, the slope can be estimated by using the position of the contour crossings from the map projected onto the position of the channel for the period in question and then measuring the channel length between the crossings for that period.

Channel sinuosity (P) is the ratio of the channel length (CL) to the valley length (VL) over a given reach. Some researchers prefer to measure sinuosity by measuring the straight-line distance from crossing to crossing between each bend. However, this can be problematic, especially where the channel has an extremely large number of highly contorted and compressed bends that wander back and forth across the valley floor. Therefore, for the purposes of this project, sinuosity is obtained by measuring the length of the channel orientation line (as shown in Figure 26) between two points and then measuring the channel centerline length between the same points. The channel orientation line defines the direction along which the channel is flowing across the valley floor and the length measured between the two pre-defined points is the valley length of the channel used in the sinuosity calculations.

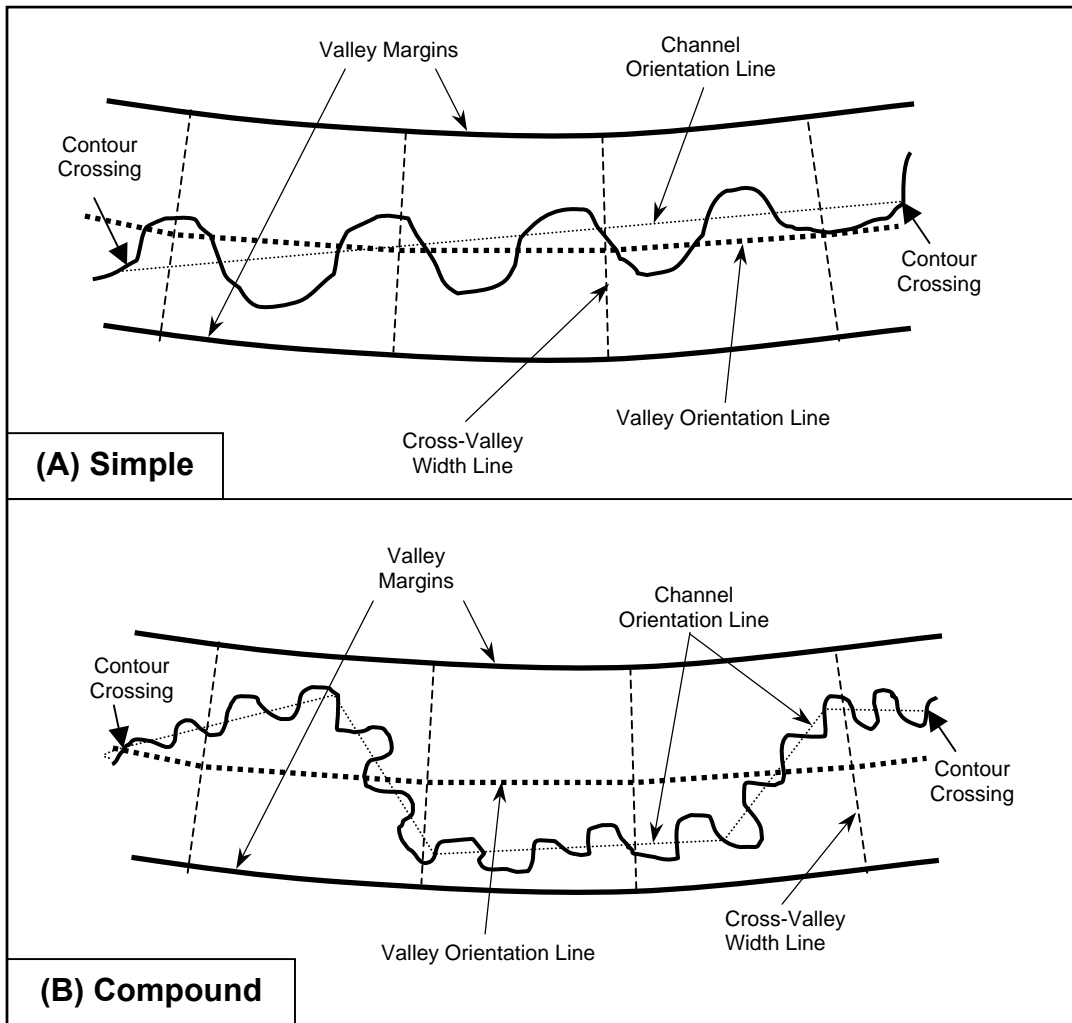

Figure 26. Simple (A) and compound (B) channel orientations used in valley slope determinations.

Measuring Meander Migration

Before predictive tools for channel migration can be developed, one must be able to measure and describe channel migration. A standard approach for use in analyzing data sets must be developed and this approach should be adhered to for all subsequent measurements.

The initial or existing meander bend should be represented by a starting point (upstream end), an ending point (downstream end), a location of the center of bend radius (bend centroid), an orientation with respect to a baseline (e.g., down valley direction), and an outside bank radius (R_C). As shown in Figure 27, it can be assumed that the bend starts and ends at the flow crossing.

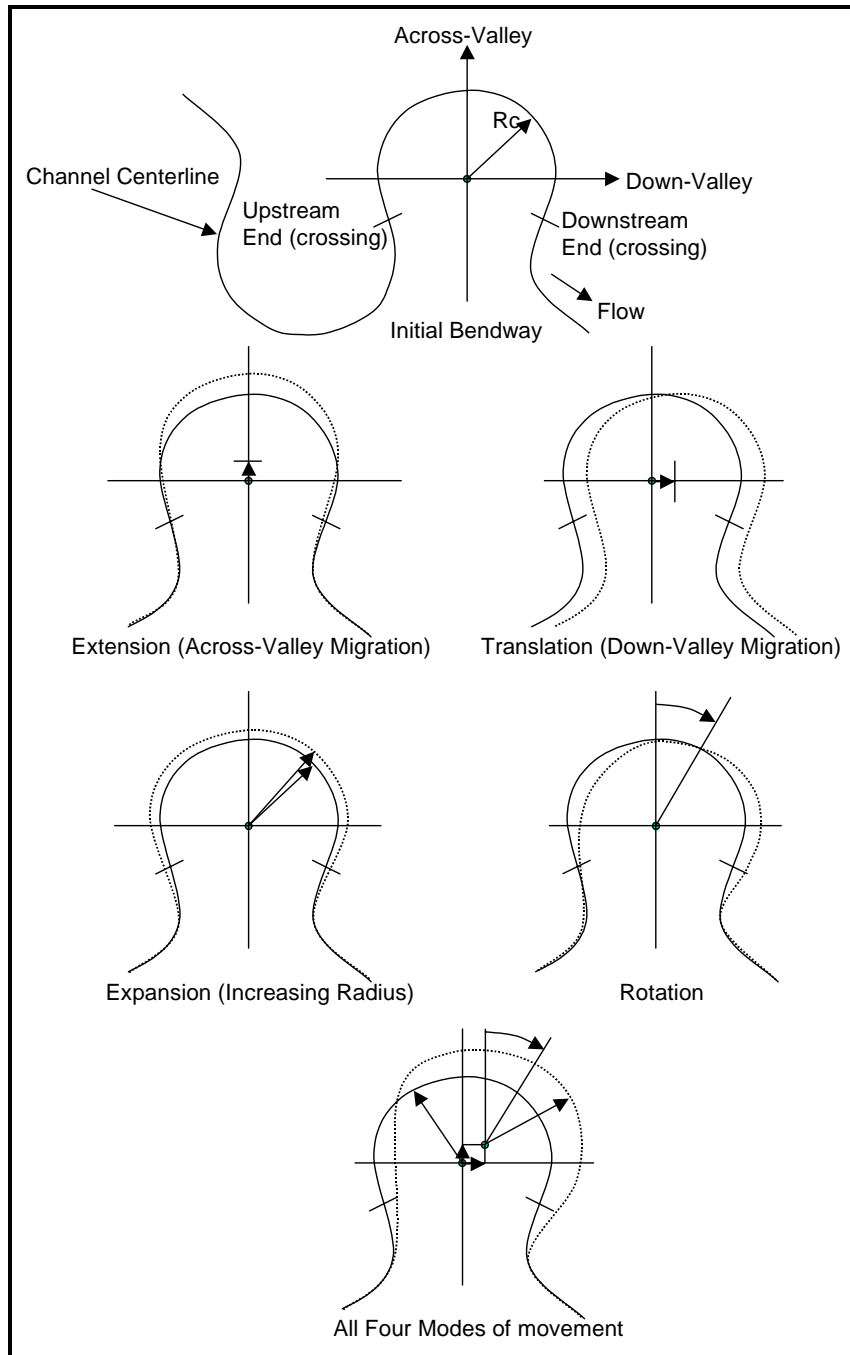

Figure 27. Measuring meander migration.

Bend migration can be reasonably described by four modes of movement. Extension is across-valley migration and is easily measured at the bend centroid. Similarly, translation is down-valley migration and is also measured at the bend centroid. Expansion (or contraction) increases (or decreases) bend radius. Rotation is a change in the orientation of the meander bend with respect to the valley alignment.

A change in any of these four modes of movement results in a change in the location of the outer bankline. Combinations of these modes of movement would result in a wide variety of meander bend shapes through time. To apply this approach one must identify a valley orientation, locate the bend centroid, and measure the bend radius and orientation of the bend with respect to the valley. If this is performed for consecutive aerial photos, rates of change in each of the modes of movement can be computed. This type of geometric information is needed to graphically depict channel migration of individual bends.

Predicting four modes of movement is a significant task for every bend of interest (Figure 27). However, actual bend migration is even more complex. For example, one part of the bend may be expanding faster or translating down-valley faster than another resulting in changes in bend symmetry. As a concession to practicality one must limit the number of modes of movement to the fewest possible. In the methodology developed, extension and translation are considered directly (as a vector sum). Expansion (a change in R_C) is included as it could have a major impact on the location of the outer bank and because rates of migration appear to be correlated to R_C/W (bend radius of curvature/width). If movement in these three modes can be predicted, the primary threats to a bridge, highway, or other facility will be established. Rotation is considered only indirectly as a component of the combined movement in the other three modes relative to adjacent bends.

GIS Measurement Tool

ArcView is a GIS and mapping software package developed by Environmental Systems Research Institute Inc. (ESRI). An ArcView extension, the meander bend Data Logger, is a GIS-based, menu-driven, circle-template methodology that was developed to streamline the measurement and analysis of bend migration data and aid in predicting channel migration.

The Data Logger provides users with a quick and easy way to gather and archive river planform data. The physical banklines are represented by one or more ArcView themes. A theme is a set of geographic features in a view. A view is an interactive map that allows the user to display, explore, query and analyze geographic data in ArcView. The bend delineation points for each bend and each historical record are archived in individual themes to provide a graphical record of the user's interpretation of each bend. For each river bend and each historical record, the Data Logger records various river characteristics (bend radius, bend center, river widths, bend wavelength, etc.). This data is organized by river reach and recorded in a table identified by the reach name. Figure 28 shows some of the measurements made using Data Logger.

Data Logger requires the following actions to be performed at each bend for each historical record:

1. Locate registration points along the outer bank on a river bend.
2. Inscribe an arc of a circle using the registration points to describe the bend radius (R_c) and orientation.
3. Estimate the channel widths (W) at the bend apex and at the upstream and downstream crossings (ends of the bends).
4. Estimate the meander wavelength (λ) and bend amplitude (A).

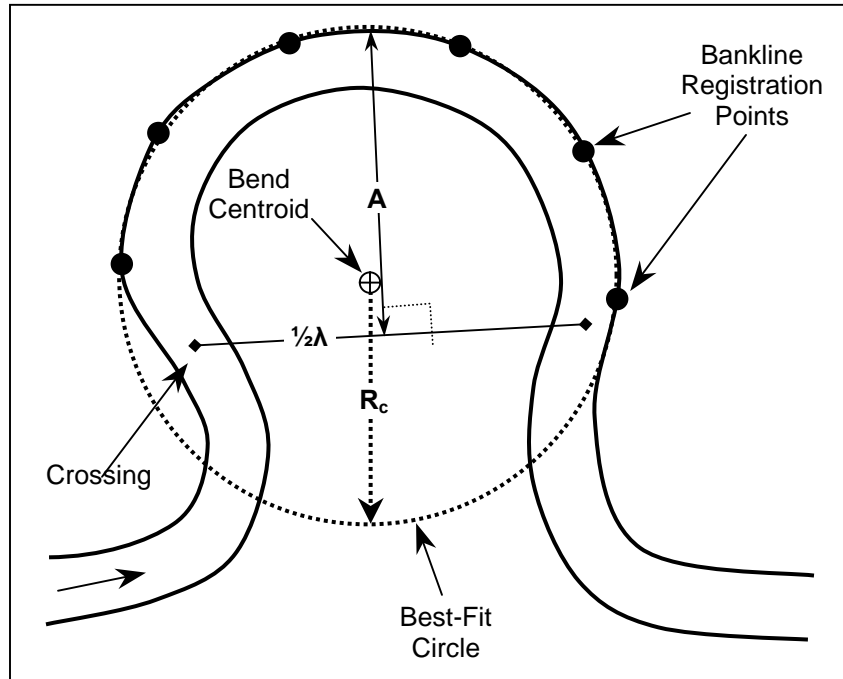

Figure 28. Some of the bend measurements made using the Data Logger.

Radius of Curvature

The radius of curvature (R_c) of the outside bankline is defined by setting 5 to 7 registration points along the bankline from the beginning of the bend to the end of the bend (Figure 28). Once the points are set, a circle is inscribed on the bend that best fits the registration points and best describes the bend. The centroid of the circle represents the centroid of the bend and the radius of the circle defines the radius of curvature of the outer bank.

Meander Bend Orientation

A line that extends from the bend centroid to a point on the outer bank arc midway between the upstream and downstream end points defines the bend orientation (Figure 28). Like the valley orientation angle, the bend orientation angle is measured counterclockwise from a zero angle defined to be due east.

Meander Wavelength and Amplitude

The meander wavelength (λ) is defined by identifying the upstream and downstream crossings, setting a point at the centerline of the river at the crossings, and then drawing a line between the points. The wavelength is twice the length of this line. The bend amplitude (A) is defined by a line drawn perpendicular to the wavelength line between the wavelength line and the outer bank at the bend apex. The bend apex is the farthest extension of the outer bank relative to the bend centroid.

Channel Width

Channel widths are measured from top bank to top bank at the crossings and at the widest point in the bend. The channel width of the crossing in the data set is the average of the channel width at both crossings. The widest point of the channel generally occurs near the bend apex. All the width measurements are made and recorded using the GIS measurement tool.

SCREENING AND CLASSIFICATION PROCEDURES

One of the objectives of this project was the development of a quantitative screening procedure to identify stable meandering reaches [e.g., Brice's (49) equal width vs. random width comparisons]. In addition, a classification system for river/meander types was developed to support stratification of the data base for use in the quantitative multiple regression analyses.

Screening

Rivers are often categorized as either straight, meandering, braided, or anabranching. The range of channel types for meandering, braided, and anabranching channels is illustrated in Figure 10. The degree and character of sinuosity portions of Figure 10 are directly related to the objectives of this project, whereas the braided and anabranching portions are not. Therefore, the first step in screening is to identify and remove the braided and anabranching channels from the data base.

Once a channel has been identified as meandering, it should be possible to identify the stability of meanders by their width characteristics (e.g., equiwidth vs. variable width). For the purposes of this project, a meandering river was considered sufficiently stable where it does not pose a threat to bridges or highway structures.

Brice (49) attempted to discriminate qualitatively between very stable and less stable channels. He discovered that channels that do not vary significantly in width were relatively stable, whereas channels that were wider at bends were more active. Brice demonstrated this by plotting sinuosity against an erosion index (erosion rate in channel widths per year times percent of reach eroded times 100). High sinuosity equal-width streams were the most stable, whereas other equal-width streams of lower sinuosity were less stable, and wide bend streams had the highest erosion rates. This simple stratification of meanders will be of value to the bridge engineer as a screening procedure, allowing preliminary identification of meanders that are very stable. Brice's conclusions were validated by the expanded data base assembled for this project (see Chapter 2, Regression Analysis).

Meander Classification

Channel classification systems provide engineers with useful information on typical characteristics associated with a given river type and establish a common language as a basis for communication. Although classifications are useful for clarity of communication and as an index of the numerous types of channels that exist, it is the characteristics of an individual channel that are important in defining channel processes and response. Classification systems, alone, are of little value for deriving process significance or predicting channel response (see for example, (222)). When quantitative information about a river is available, classifications are only the first step in evaluating channel stability and predicting channel change.

A classification procedure modified from the channel pattern classification originally developed by Brice (72) (Figure 10) was developed for this project for both screening and classification (Figure 11). This approach was based on the evaluation of a number of classification schemes (72, 126, 201, 202, 203, 204, 205, 206, 207), and is the most applicable to project objectives. The following paragraphs provide a survey and appraisal of other classification procedures considered.

Assuming a graded stream, one that is neither progressively aggrading or degrading, the type of sediment transported by the river has a major influence on channel shape, pattern, and gradient. Table 6 summarizes a classification of alluvial channels based on the relative proportions of sand and silt-clay transported by a stream. Based on studies of rivers on the great plains of the United States and the riverine plain of Australia, it was determined that suspended-load streams that transported very little bedload were narrow, deep, gentle, and sinuous whereas bed-load streams were wide, shallow, steep, and relatively straight. This classification relates channel characteristics to type of sediment load. During experimental studies it was further determined that valley gradient exerted a major influence on channel patterns.

Table 6. Classification of Alluvial Channels (126).

Mode of Sediment Transport and Type of Channel	Bedload (percentage of total load)	Channel Stability		
		Stable (graded stream)	Depositing (excess load)	Eroding (deficiency of load)
Suspended Load	<3	Stable suspended-load channel. Width/depth ratio <10; sinuosity usually >2.0; gradient, relatively gentle	Depositing suspended load channel. Major deposition on banks cause narrowing of channel; initial streambed deposition minor.	Eroding suspended-load channel. Streambed erosion predominant; initial channel widening minor.
Mixed Load	3-11	Stable mixed-load channel. Width/depth ratio >10 <40; sinuosity usually <2.0 >1.3; gradient, moderate	Depositing mixed-load channel. Initial major deposition on banks followed by streambed deposition.	Eroding mixed-load channel. Initial streambed erosion followed by channel widening.
Bed Load	>11	Stable bed-load channel. Width/depth ratio >40; sinuosity usually <1.3; gradient, relatively steep	Depositing bed-load channel. Streambed deposition and island formation.	Eroding bed-load channel. Little streambed erosion; channel widening predominant.

Figure 29 suggests that the range of channels from straight through braided forms a continuum, but experimental work and field studies have indicated that within the continuum, river-pattern thresholds can be identified where the pattern changes between straight, meandering, and braided. The pattern changes take place at critical values of stream power, gradient, and sediment load (202).

In addition to the channel patterns shown in Figure 29, there are five basic bed-load channel patterns (Figure 30A) that have been recognized during experimental studies of channel patterns. These five basic bed-load channel patterns can be extended to mixed-load and suspended-load channels to produce 13 patterns (Figure 30). Patterns 1-5 are bed-load channel patterns (Figure 30A), patterns 6-10 are mixed-load channel patterns (Figure 30B), and patterns 11-13 are suspended-load channel patterns (Figure 30C). For each channel type, pattern changes can be related to increasing valley slope, stream power, and sediment load.

The different bed-load channel patterns (Figure 30A) can be described as follows: Pattern 1: straight, essentially equal-width channel, with migrating sand waves; Pattern 2: alternate-bar channel with migrating side or alternate bars and a slightly sinuous thalweg, Pattern 3: low-sinuosity meandering channel with large alternate bars that develop chutes; and Pattern 4: transitional meandering-thalweg braided channel. The large alternate bars or point bars have been dissected by chutes, but a meandering thalweg can be identified. Pattern 5 is a bar-braided channel.

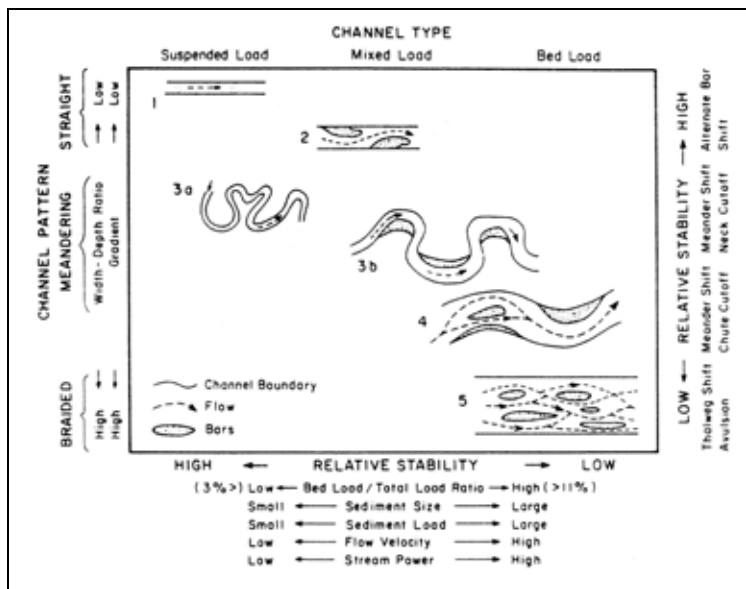

Figure 29. Channel classification and relative stability as hydraulic factors are varied (203).

As compared to the bed-load channel pattern, the five-mixed load patterns (Figure 30B) are relatively narrower and deeper, and there is greater bank stability. The higher degree of bank stability permits the formation of narrow, deep straight channels (Pattern 6), and alternate bars stabilize because of the finer sediments, to form slightly sinuous channels (Pattern 7). Pattern 8 is a truly meandering channel, wide on the bends, relatively narrow at the crossings, and subject to chute cutoffs. Pattern 9 maintains the sinuosity of a meandering channel, but due to the greater sediment transport the presence of bars gives it a composite sinuous-braided appearance. Pattern 10 is an island-braided channel that is relatively more stable than that of bedload channel 5. Suspended-load channels (Figure 30C) are narrow and deep. Suspended-load Pattern 11 is a straight, narrow, deep channel. With only small quantities of bed load, this type of channel will have the highest sinuosity of all (Patterns 12 and 13).

The linkage between sediment-load characteristics and planform provided by Table 6 and Figure 30 were important in interpreting the results of the data analysis for this project. This linkage was considered in developing the recommended classification of Figure 11. However, to use sediment load type as a primary classification approach could require a substantial field sampling program for every river/bend to be analyzed by the user of the prediction methodology. The pictorial approach of Figure 11 was considered more directly applicable to State DOT needs. It requires only a map, photograph, or visual inspection to apply. Application of this procedure to 58 Brice sites indicates that all sites would fit into one of the categories, without apparent anomalies, and the classification results are replicable.

The preceding classification applies to adjustable alluvial rivers, with sediment loads primarily of sand, silt and clay, which would be considered regime channels by Montgomery and Buffington (205) who considered the full range of channels from high mountain bedrock channels to those described previously in Figures 29 and 30. This classification (Figure 31) starts at the drainage divide and moves down through bedrock and colluvial depressions or chutes to the point where one can recognize fluvial channels. Five distinct reach morphologies are identified: cascade, step-pool, plane-bed, pool-riffle, and dune-ripple (regime). Most of these reaches will be confined by valley walls and terraces in contrast to the alluvial regime channels. Table 7 summarizes the important characteristics of each channel type. Since reach morphologies are considered in profile, rather than in planform, this classification would not contribute to an analysis focused on meander mode or sinuosity.

Rosgen (206, 207) developed a comprehensive system for classifying natural rivers. This system divides streams into seven major types on the basis of degree of entrenchment, gradient, width/depth ratio, and sinuosity. Within each major category there are six subcategories depending on the dominant type of bed/bank materials. The classification system shows a distinct bias toward streams that are relatively small and steep. For example, of the stream types categorized based on dominant bed material, seven are braided, 30 are entrenched, in the sense that overbank floods are confined by valley walls or terraces, and four are narrow, sinuous mountain meander-type channels. The basic framework of Rosgen's method is set out in Figures 32 and 33. While this classification is comprehensive in its scope, just as with the Montgomery and Buffington approach of Figure 31 and Table 7, it does not support classifying rivers based on meander mode or sinuosity.

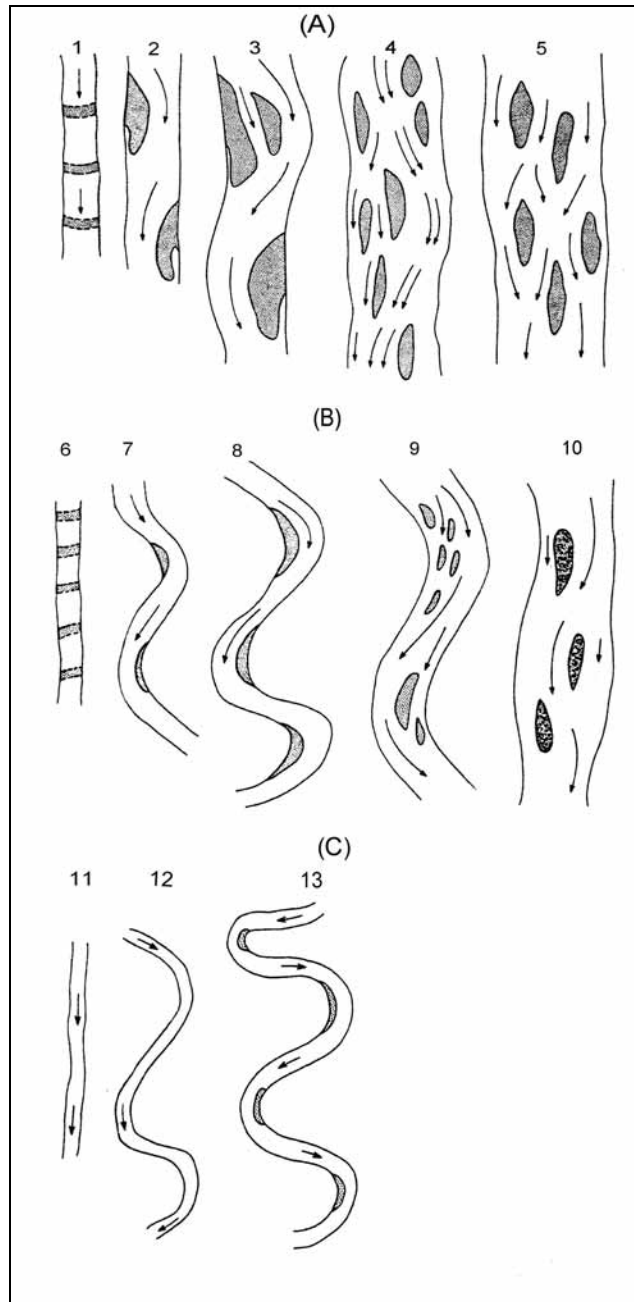

Increasing Valley Slope
 Increasing Stream Power ⇒
 Increasing Sediment Load

Figure 30. The range of alluvial channel patterns. (A) Bed-load channel patterns, (B) Mixed-load channel patterns, (C) Suspended-load channel patterns (204).

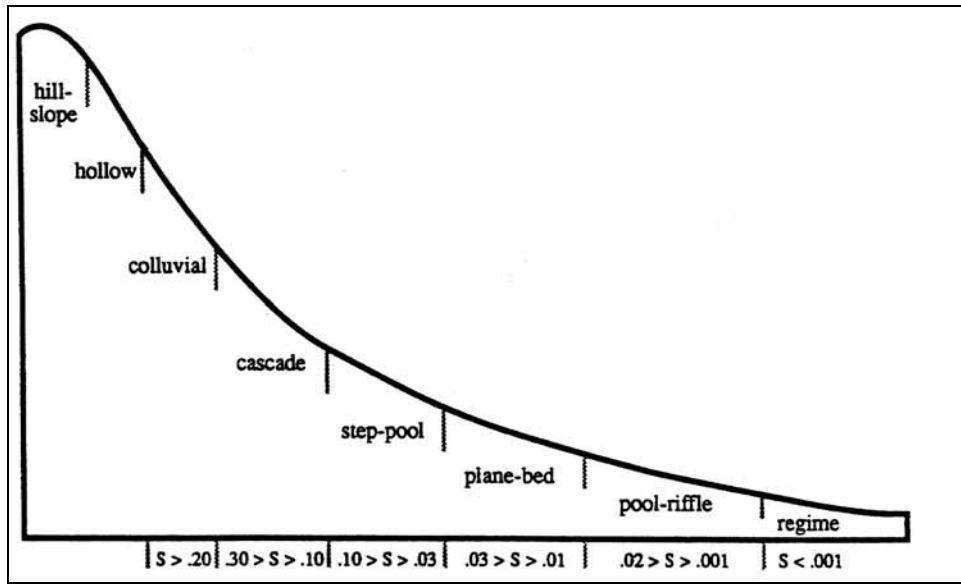

Figure 31. Idealized long profile from hillslopes and unchanneled hollows downslope through the channel network showing the general distribution of alluvial channel types (from (205)).

Summary

Of the approaches reviewed, the classification system of Figure 11 was adopted as the most applicable for the purposes of this project. As shown in Figure 11, nine screening and classification categories can be used to represent the full range of meandering rivers encountered in the field. As noted above, equiwidth rivers, such as A, B₁, and G₁, can be screened as stable. One class, the "wandering" river shown as F, should be screened as potentially so unstable and unpredictable that further evaluation would not be likely to produce a meaningful result (in terms of predicting meander migration). All other meandering rivers can be classed as one of the remaining five categories, B₂, C, D, E, G₂, and analyzed by the photogrammetric comparison techniques presented in the Handbook. This approach incorporates the following characteristics:

- Simple and directly applicable to the meander process with minimal training and/or explanation
- Combines a classification system with a screening procedure to identify stable or highly unstable patterns
- Pictorial in format, requiring only a map, aerial photograph, or visual inspection to apply
- Provides a reasonable range of classes with which to segment the meander data base
- Does not require field data (e.g., sediment sampling) to apply
- Test case shows that most meandering river types or meander modes of interest to this project will fall in these categories
- Test case shows that results are replicable when applied to the same data set by different evaluators

Table 7. Classification of Channel-Reach Morphology in Mountain Drainage Basins of the Pacific Northwest (from (205)).							
	Dune Ripple	Pool Riffle	Plane Bed	Step Pool	Cascade	Bedrock	Colluvial
Typical bed material	Sand	Gravel	Gravel-cobble	Cobble-boulder	Boulder	Rock	Variable
Bedform pattern	Multilayered	Laterally oscillatory	Featureless	Vertically oscillatory	Random	Irregular	Variable
Dominant Roughness Elements	Sinuosity, bedforms (dunes, ripples, bars) grains, banks	Bedforms (bars, pools), grains, sinuosity, banks	Grains, banks	Bedforms (steps, pools), grains, banks	Grains, banks	Boundaries (bed and banks)	Grains
Dominant Sediment Sources	Fluvial, bank failure	Fluvial, bank failure	Fluvial, bank failure, debris flows	Fluvial, hillslope, debris flows	Fluvial, hillslope, debris flows	Fluvial, hillslope, debris flows	Hillslope, debris flows
Sediment Storage Elements	Overbank, bedforms	Overbank, bedforms	Overbank	Bedforms	Lee and stoss sides of flow obstructions	Pockets	Bed
Typical Confinement	Unconfined	Unconfined	Variable	Confined	Confined	Confined	Confined
Typical Pool Spacing (channel widths)	5 to 7	5 to 7	None	1 to 4	<1	Variable	Unknown

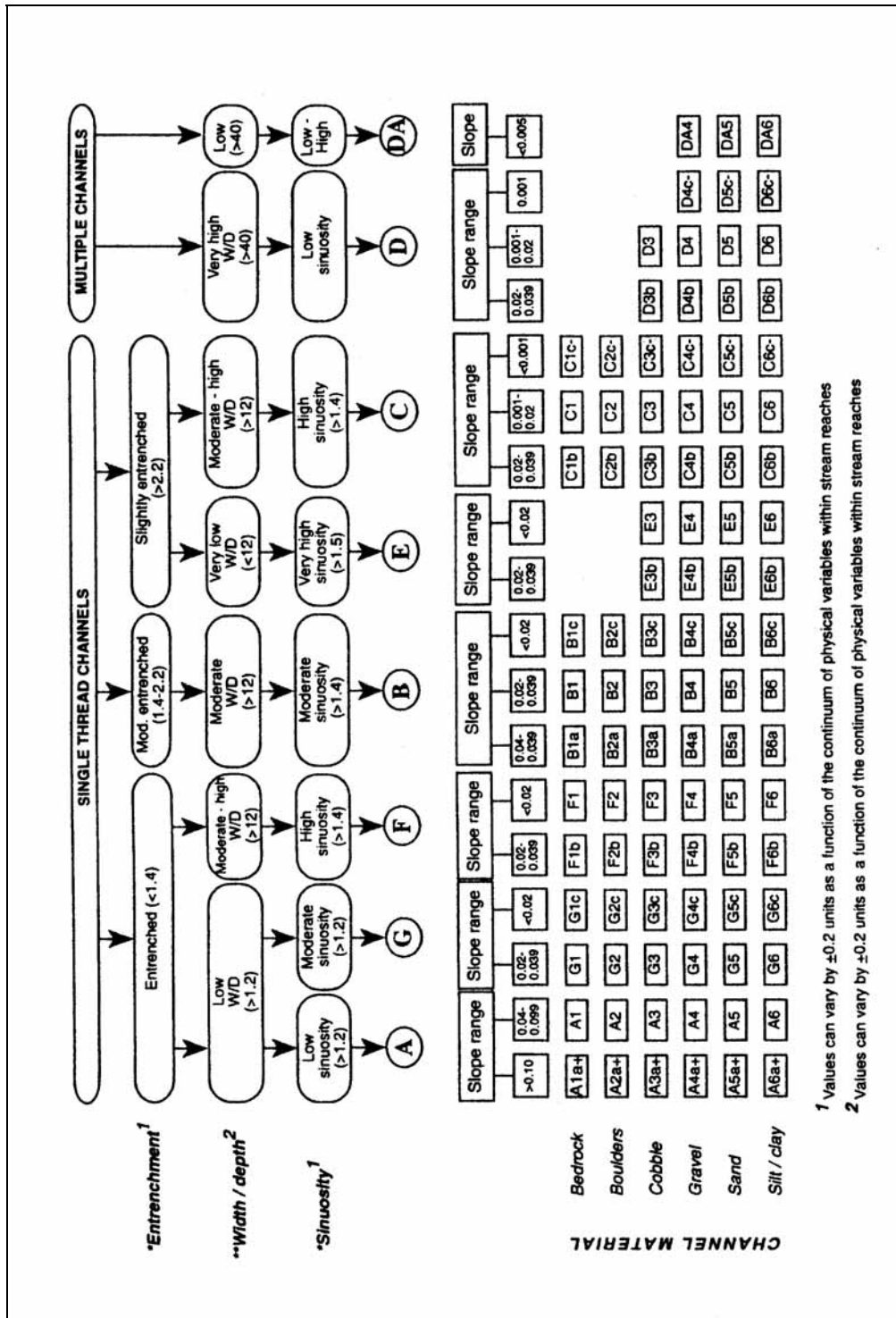

Figure 32. Key to classification of rivers in Rosgen's method (modified from Rosgen (206) by Thorne (200)).

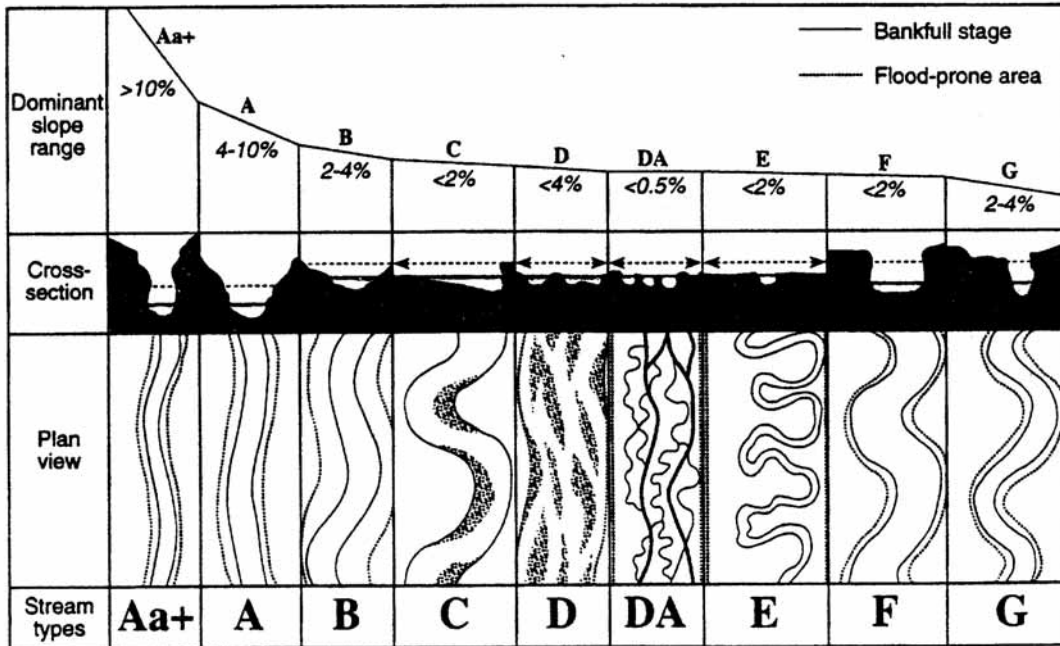

Figure 33. Longitudinal, cross-sectional, and planform views of major stream types in Rosgen's method (modified from Rosgen (206) by Thorne (200)).

AERIAL PHOTO COMPARISON METHODOLOGY

In Chapter 2 (The Handbook), three methodologies for predicting meander migration are summarized: manual overlay techniques, computer supported techniques, and GIS-based measurement and extrapolation techniques. This section outlines the steps necessary to conduct a detailed meander migration analysis using aerial photo comparison techniques. The manual overlay of historic maps and aerial photos is used to illustrate the general comparative approach and the application of the acquired data and information to predict the position of a meander bend in the future. The computer assisted technique differs from this general approach only in the use of common computer software to assist in the historic assessment and prediction of bend migration. Similarly, the GIS-based technique applies the same general approach but uses the Data Logger and Channel Migration Predictor ArcView extensions supplied with the Handbook to conduct the comparison and prediction steps. Sources of error and limitations of the map and aerial photo comparison techniques are also appraised in this section.

Manual Overlay and Prediction

The following steps illustrate a simple overlay comparison of historic banklines and the process of predicting the potential future position of a bend based on past channel migration characteristics.

STEP 1 - The first step in conducting a meander migration analysis using an overlay technique is to obtain aerial photographs and maps for the study area. As summarized in Chapter 2, the Handbook provides a detailed listing of sources and Appendix A of the Handbook provides general instructions on downloading digital aerial photographs and topographic maps from Microsoft's TerraServer Web site.

STEP 2 - The maps and photos must be enlarged or reduced to a common working scale. The scale of the most recent map or photo should be used since it will be the basis for making and comparing historical meander pattern changes and predicting the position of a given bend in the future.

STEP 3 - After defining a working scale, the photos and maps are registered to a common base map or photo by identifying several features or points that are common to each photo/map being compared. The registration points do not need to be common to all the maps and photos, only to the subsequent map or photo to which it is being compared, since comparisons can be performed in pairs.

For example, Figures 34 and 35 show the 1937 and 1966 aerial photos, respectively, for a reach of the White River in Indiana. Four registration points have been identified on the 1937 photo that are also on the 1966 aerial photo. Two registration points are road intersections and two are isolated vegetation (trees or large shrubs). Registration points that bracket the site on both sides of the stream and at both ends of the reach are most useful because they reduce the amount of potential error within the bracketed area. Intermediate points between the end points are helpful in accurately registering the middle sections of the reach. More than five or six registration points can make registration difficult because of the difficulty in aligning all the registration points among the various aerial photos and maps used. However, there will be instances where there will be very few identifiable registration points common to both photos, and these sites may have the potential for significant error.

STEP 4 - After identifying the registration points, banklines and registration points for each year are traced from the aerial photo onto a transparent overlay. The method for identifying and tracing the banklines is described in detail in Chapter 5 and Appendix B of the Handbook. Registration points are included on the overlay so that they can be easily plotted onto other aerial photos or maps for comparative purposes. The traced banklines and registration points of the White River for 1937 are plotted on the 1966 aerial photo in Figure 36 for comparative purposes.

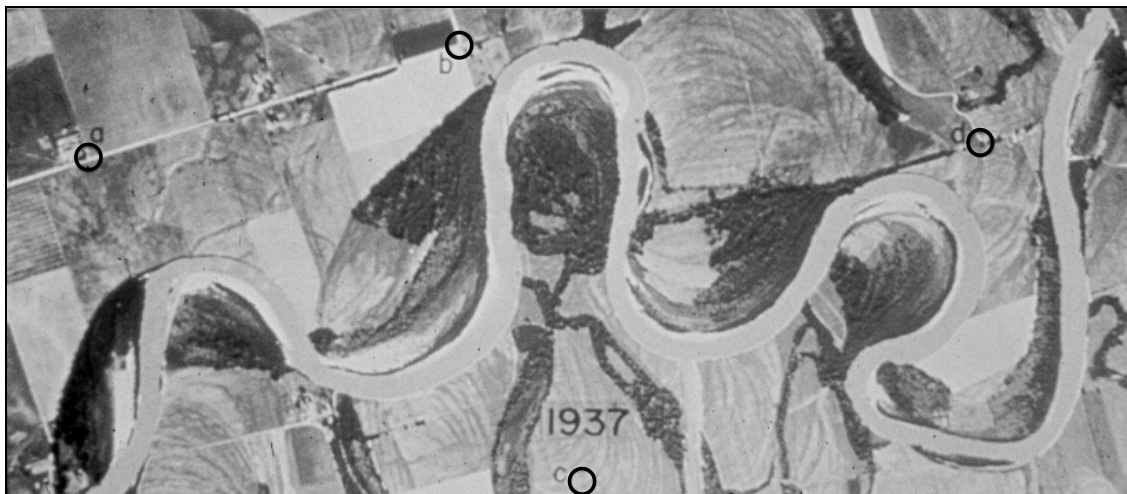

Figure 34. Aerial photograph of a site on the White River in Indiana showing four registration points (circles designated a through d) common to the 1966 aerial photo.



Figure 35. Aerial photo of a site on the White River in Indiana showing the four registration points common to the 1937 aerial photo in Figure 34.

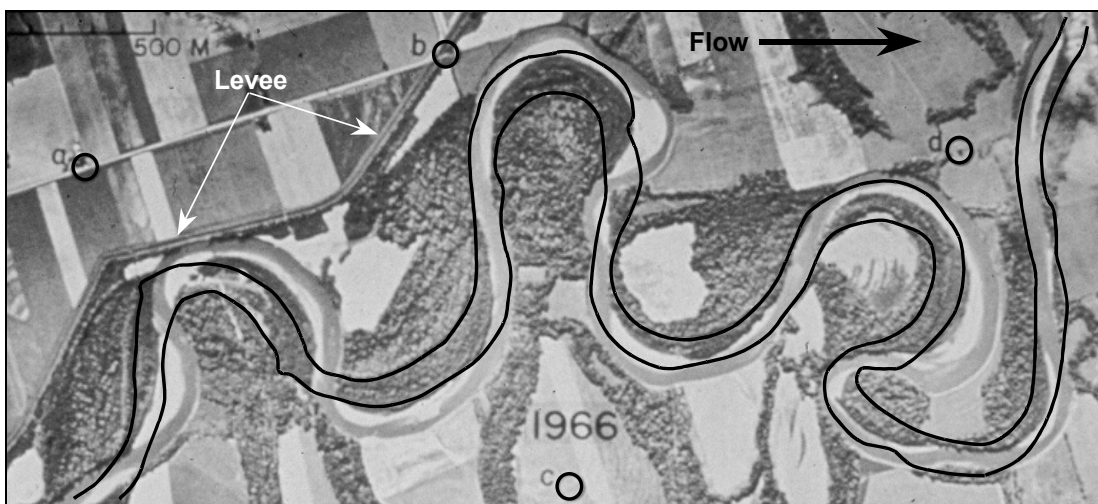

Figure 36. The 1966 aerial photo of the White River in Indiana with the 1937 bankline tracing and registration points.

Since most meander bends are not simple loops, the loop classification of Brice (72) can be used to characterize the shape of each bend that is to be analyzed (Figure 37). Meander bends seldom form single symmetrical loops, but instead are comprised of one or more arcs combined to form either symmetrical or asymmetrical loops. Brice (72) derived the classification scheme for meander loops from a study of the meandering patterns of 125 alluvial streams. The scheme consists of four main categories of loops (simple and compound symmetrical and asymmetrical) comprising 16 form types. Although compound loops are regarded as aberrant forms of indefinite radius and length, the meandering patterns can be divided into simple loops whose properties can be described, measured, and analyzed. The radius of curvature of most bends can be defined by fitting one or more circles or arcs to the bend centerline or outer bankline of a meander loop.

STEP 5 - Once the banklines for each of the historic aerial photos have been traced, circles are best-fit to the outer bank of each bend to define the average bankline arc, the radius of curvature (R_C) of the bend, and the bend centroid position (Figure 38). The number of circles required to define the bend is based on the loop classification described above and shown in Figure 37. A detailed description of the method used to fit a circle to the outer bankline of a meander bend is provided in Appendix B of the Handbook. The radius of curvature and centroid position of the circle used to describe the bend will be used to make comparison with the bend measurements of previous and subsequent years. These measurements can then be used to determine migration rates and direction and estimate future bend migration characteristics.

Figure 39 compares the best-fit circles and bend centroids for each bend traced from the aerial photographs for 1937 and 1966. The vector arrow at each bend shows the direction and magnitude of movement of the bend centroid between 1937 and 1966. For each bend, this vector may be resolved into cross- and down-valley components to determine the rates of meander migration. The change in radius of curvature of each bend is defined by the difference between the magnitudes of the vectors for 1937 and 1966.

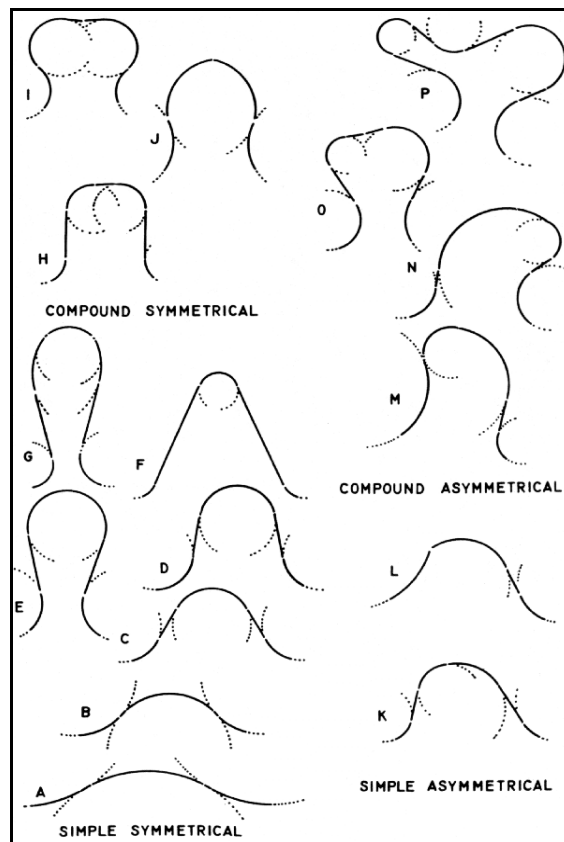

Figure 37. Meander loop evolution and classification scheme proposed by Brice (72). Flow is left to right.

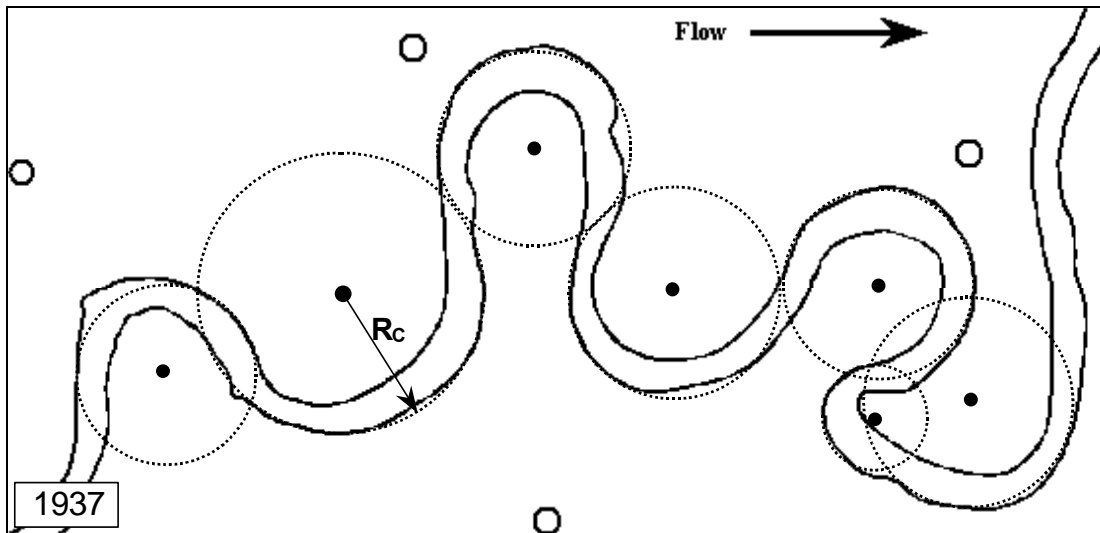

Figure 38. Circles that define the average outer banklines from the 1937 aerial photo of the White River site in Indiana. Also shown are the bend centroids and the radius of curvature (R_C) for one of the bends.

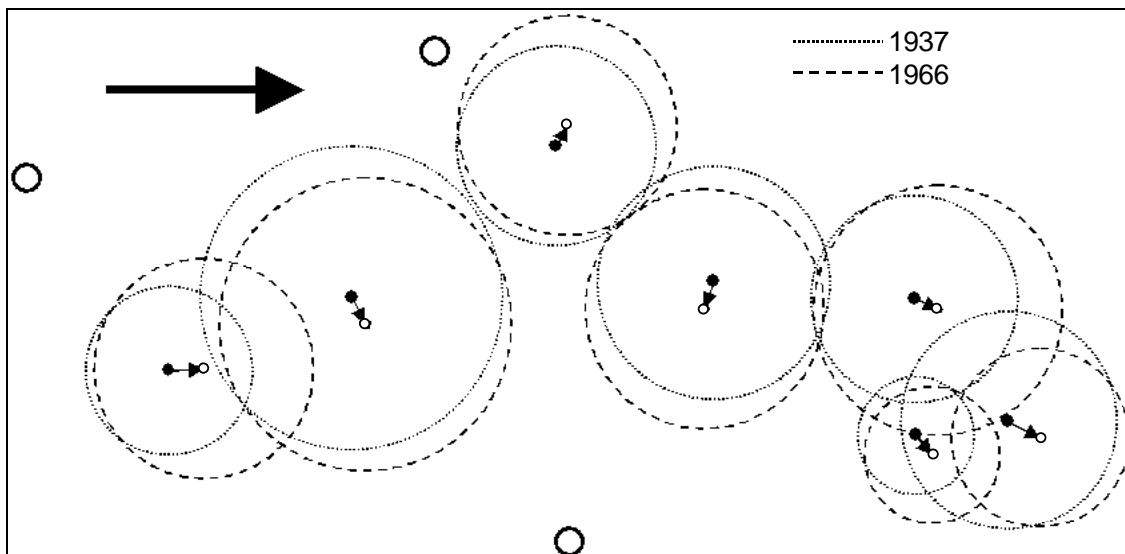

Figure 39. Depiction of the bends from 1937 (dotted line) and 1966 (dashed line) outer banklines as defined by best-fit circles. The movement of the bend centroids (arrows) defines migration of the bends.

STEP 6 - The position of the bend at a selected date in the future can be predicted by simple extrapolation if it is assumed that the bend will continue to move at the same rate and in approximately the same direction as it has in the past. To estimate the position of a bend centroid in 1998, for example, the distance the centroid would be expected to move during the 32 years between 1966 and 1998 can be determined by multiplying the annual rate of movement for the 1937 to 1966 period by 32. This distance is plotted along a line starting at the 1966 centroid point and extending in the direction defined by the 1937 to 1966 migration vector. The radius of curvature of the bend in 1998 can be defined by determining the rate of change of the bend radius from 1937 to 1966 relative to the 1966 radius and multiplying this value by number of years from 1966 to 1998. A circle with that radius, centered on the predicted location of the centroid, is plotted on the tracing to indicate the expected location and radius of the bend in 1998.

Figure 40 shows the expected outer bank circles for each of the bends of the White River in 1998, based on simple extrapolation of the rates and directions of change during 1937-66. Banklines for the 1998 channel can then be constructed on the tracing by joining the outer bank circles through interpolation, with the 1937 and 1966 banklines used to indicate the reach-scale configuration of the channel.

Figure 41 shows the banklines observed in 1937 and estimated for 1998, overlain on the 1966 aerial photo. Inspection of the estimated banklines reveals that Bend 1 would encroach into the levee to the north by 1998 while growth of Bend 5 would likely cutoff Bends 6 and 7.

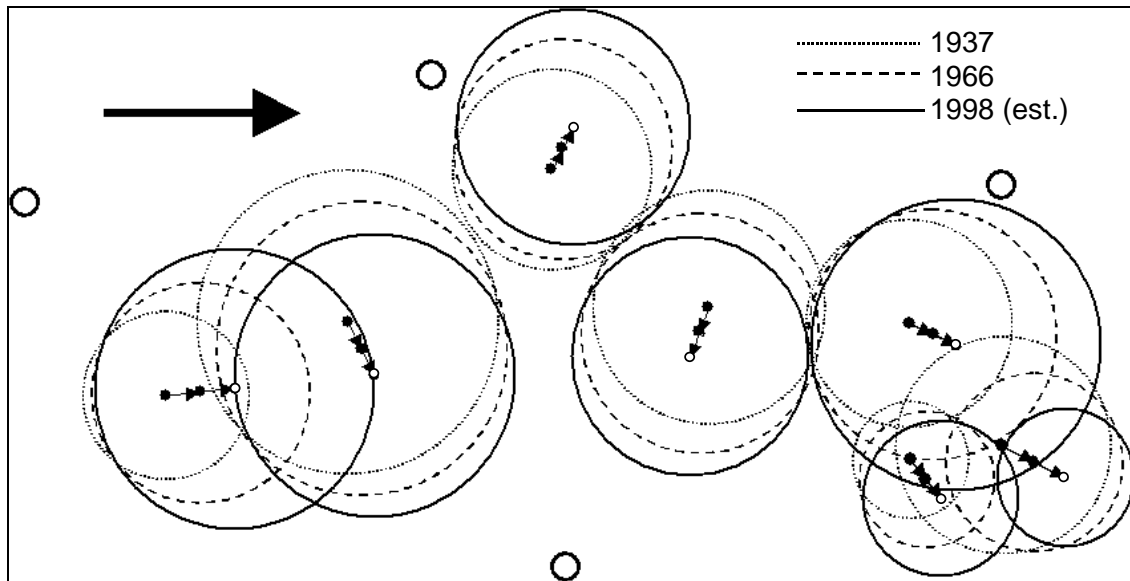

Figure 40. Depiction of the bends from the 1937 (dotted line) and 1966 (dashed line) outer banklines, as defined by best-fit circles, and the predicted location and radius of the 1998 outer bankline circle (solid line).

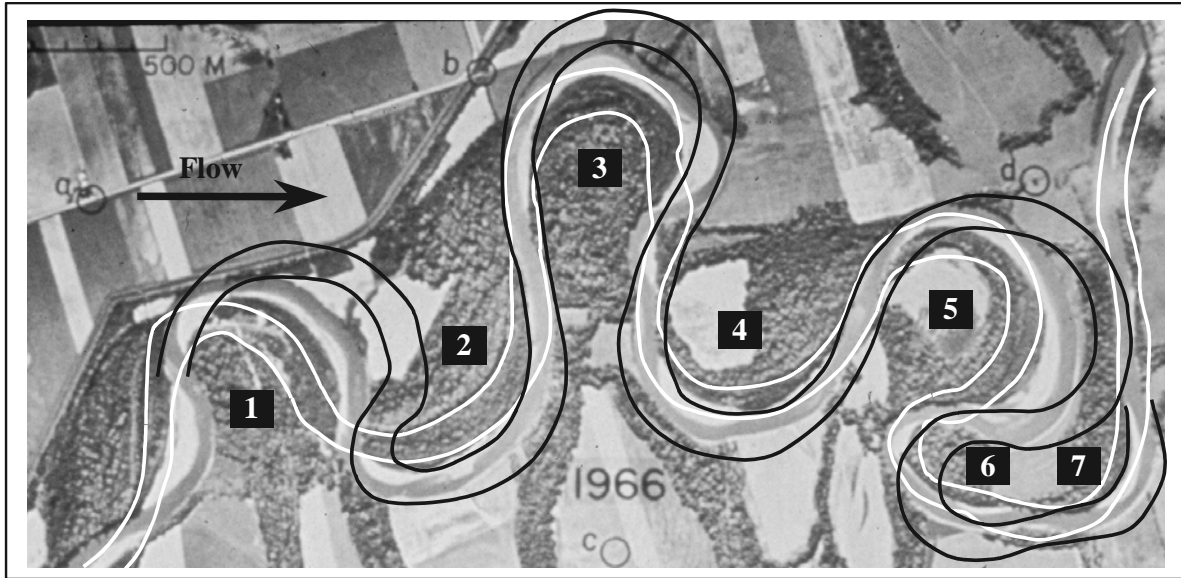

Figure 41. Aerial photo of the White River in 1966 showing the actual 1937 banklines (white) and the predicted 1998 bankline positions (black).

In Figure 42 the banklines predicted for 1998 by extrapolation of trends of change between 1937 and 1966 are superimposed on an aerial photograph taken in 1998. Two of the registration points used for this comparison are different because two of the original registration points from the previous aerial photos are no longer present on the 1998 aerial photo.

Comparison of the actual and estimated banklines in Figure 42 illustrates that meander migration can be predicted relatively accurately using this simple approach. For example, the positions of Bends 3 and 4 and the cutoff at Bend 5 are accurately predicted. Errors in the predicted banklines can be accounted for by: (1) an artificial cutoff that affected Bends 1 and 2; (2) the natural cutoff at Bend 5 that led to Bends 6 and 7 being abandoned; and (3) construction of bank protection at Bends 3 and 5 during the period 1966-95. The artificial cutoff at Bend 1 may have been in response to the serious threat posed by bend migration toward the nearby levee. That cutoff caused Bend 2 to distort in a way that could not have been predicted from its previous behavior. Outer bank migration at Bends 3 and 5 appears to have been curtailed by bank revetments. The migration of Bends 3, 4, and 5, the cutoff of Bend 5, and the abandonment of Bends 6 and 7 were predicted with sufficient accuracy to meet the objectives of this study. It is likely that the positions of Bends 1 and 2, as well as the banklines in the revetted portions of Bends 3 and 4, would have been as predicted except for these engineering interventions.

The case study of the White River used a single period (1937 to 1966) to predict the position of the banklines in 1998. To improve the reliability and accuracy of predictions it is desirable to use multiple pairs of aerial photographs to generate more than one period of analysis. By evaluating multiple periods, meander migration analysis can detect trends of change in the rate and direction of bend migration as well as time-averaged values.

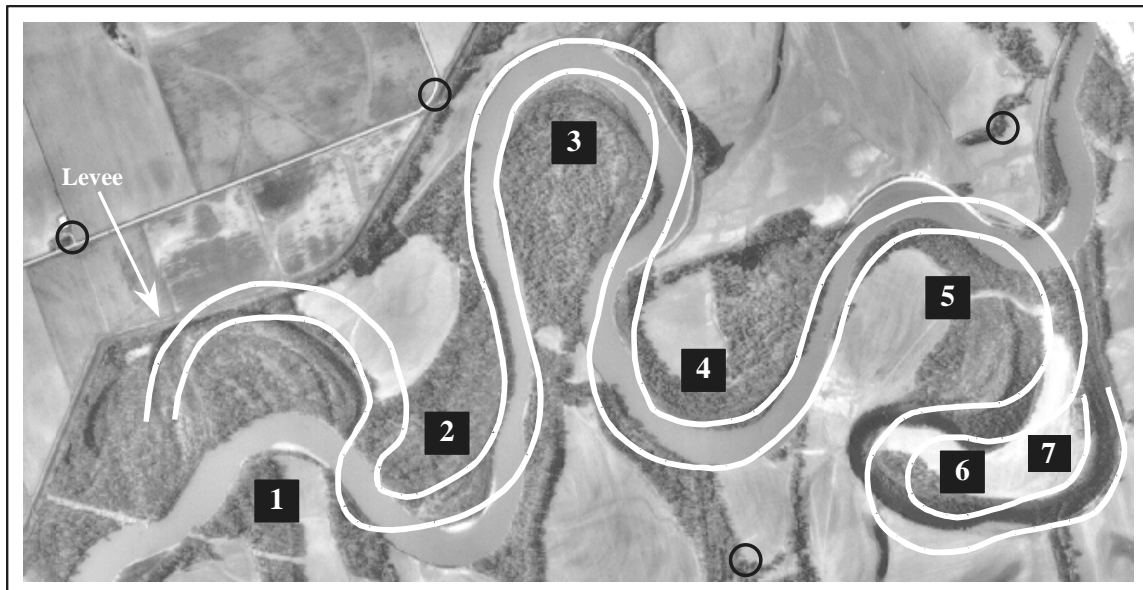

Figure 42. Aerial photograph of the White River site in Indiana in 1998 comparing the predicted bankline positions with the actual banklines.

Sources of Error and Limitations

Map and Aerial Photo Errors and Limitations

The principal errors associated with aerial photos, and ultimately with maps, are systematic errors. These are errors that follow some mathematical or physical law. A correction can be calculated and the systematic error can be eliminated if the conditions causing the error are measured and properly modeled. The major sources of these errors are:

- Film distortions due to shrinkage, expansion, and lack of flatness
- Failure of fiducial axes to intersect at the principal point
- Lens distortion
- Atmospheric refraction distortions
- Earth curvature distortion

A detailed description of the causes of these sources of error for aerial photos was considered beyond the scope of the Handbook, but can be found in most textbooks on photogrammetry (e.g., Wolf and Dewitt (223)). Depending on the precision and accuracy requirements of a given project, corrections can be applied to eliminate the effects of these systematic errors.

The primary sources of map error are associated with the vertical and horizontal accuracy and the age of the map. Most federal maps are required to meet rigorous standards for accuracy. The National Map Accuracy Standards, which were issued in 1941, apply to all Federal agencies that produce maps. Guidance is provided for horizontal and vertical accuracy and methods for testing map accuracy are outlined.

Although the Federal standards for accuracy may seem reasonable, the true accuracy of topographic maps may be insufficient or problematic when using the comparison techniques for defining and predicting meander migration. For example, if the potential horizontal error of the topographic map used in the comparison is a significant percentage of the actual channel width, then there can be substantial error between the mapped bankline position and the true bankline position for the same time period and between time periods. The map error may also be problematic if comparisons are made with historic survey data.

Comparison of newer maps and aerial photos with older maps may also pose a problem since the older maps may have been compiled before the use of aerial photos. These maps are based on physical ground surveys, field notes, surveyor descriptions, and sketches made in the field. Therefore, the accuracy of historic maps decreases with increasing age.

Maps that are geo-referenced may not match the positions of geo-referenced aerial photos. This can occur if geo-referenced digital maps are obtained from sources other than the USGS and used in conjunction with geo-referenced digital aerial photographs compiled by the USGS or other agencies. There may also be problems associated with the use of different horizontal datums. However, transformations from one datum to another have become commonplace with the increasing use of GIS.

There are several potential limitations to the use of aerial photos and maps in the comparison techniques and in the evaluation of meander migration. Scale can be a significant limitation. There are potential problems associated with major scale differences between maps and photos and changes in scale on a given photograph because of distortion across the photo. In some cases, high altitude aerial photographs (scales of 1:40,000 or 1:60,000) may be all that are available for a particular site. A comparison of bankline positions from high altitude photos with those from topographic maps may be difficult because of the significant scale difference. In some cases, an enlargement of the aerial photo may provide an image of sufficient resolution or clarity to be used in the comparison. However, this is also dependent on the relative size of the channel with regard to the scale at which it is being evaluated.

Often, the physical enlargement of high altitude photos using a copier or a flatbed scanner in conjunction with photo editing software yields images with poor resolution. Even though an aerial photo can be scanned at a high resolution, the quality of the resolution and the amount of visible detail is greatly dependent on the original image quality and clarity. However, the quality of an enlarged scanned image degrades rapidly after the image has been enlarged to more than 2 or 3 times its original size. The resolution of an aerial photograph also generally decreases with age because of changes in technology over time. In contrast, digital images such as those found on the TerraServer Web site can be downloaded at various scales and resolutions.

Brightness and contrast also play a role in the usability of an aerial photograph. Photos can be too dark or too light and the contrast may be so coarse that the banklines of a channel may be difficult or impossible to identify. The time of the year or day on which the aerial photo is acquired is also important and can limit the usability of a photo. Long shadows, dense vegetation, and cloud coverage may partially or totally obscure the bankline or the entire channel. Aerial photos that were flown at midday and during winter months with little cloud

coverage are optimal. Photos flown during early spring, prior to leaf-out, may be useful, but spring floods may obscure the tops of the banks. Photos flown during summer months can be used if the density of the bankline vegetation is sparse enough to allow the user to adequately define the bankline. Otherwise, bankline positions will need to be estimated based on the locations of the crowns of the trees growing at the bankline. In this case the accuracy of the measurements is questionable.

The age of an aerial photo or map may also limit their usefulness. Old maps and photos may not have the same identifiable geographic features or landmarks that are found on newer maps and photos. In these cases, identifiable landmarks that can be used as registration points may not be present on the older maps and photos. In addition, the township, range, and section lines found on newer topographic maps whose intersections could be used as registration points, may not be in the same location or may not be available on older maps.

Measurement Error

As with any methodology that requires the physical measurement of a quantity, the accuracy and precision of the measurements conducted under the comparison technique described in the Handbook can limit the usefulness of the acquired data. Obviously those measurements made visually using a ruler or engineering scale will be less accurate than those made using a computer. Also, repetitive measurements should be made the same way each time.

Scale plays an important role in measurement error as well. Large-scale images (e.g., 1:10,000) show ground features at a larger, more detailed size and small-scale images (e.g., 1:50,000) show ground features at a smaller, less detailed size. Thus, using identical measurement techniques, measurements made on a large-scale maps and photos generally will be more accurate than those made on smaller scale maps and photos.

Meander bends are rarely perfectly round with smooth banklines. They often are oddly shaped and their banklines are irregular (see Figure 37). As a result, fitting a circle to the channel centerline or outer bank can be very difficult. As a rule, the circle should be fit to the bend centerline or outer bankline between the crossings or at the point where the bend begins to straighten or where there is a major inflection in the channel. As much of the circle as possible should intersect the bankline or centerline and the amount of area outside the circle should match the amount of area inside the circle as closely as possible. The radius of curvature of a bend centerline or bankline can be significantly different depending on how the circle is fit to the bend, especially on smaller channels.

Limitations of Overlay Techniques

Overlay techniques require the availability of adequate maps and aerial photos that cover a sufficient period of time to be useful. The identification and delineation of a sufficient number of registration points common to each map and photo are also a fundamental requirement. All the registration points do not need to be found on all the maps and photos, but an adequate number of registration points used on each map or photo should match those on the previous or following map or photo. The registration points should bracket the area of interest (this would

require at least 4 common registration points) and should not change significantly in size over time. Even when a sufficient number of registration points are available, photo distortions or inaccuracies in mapping may not allow for an accurate registration of the images. In these cases, one must decide whether "close" is good enough or if the image should be abandoned.

Excessive or very limited movement of the channel, cutoffs, and bank erosion countermeasures will also limit the usefulness of the comparison techniques. An analysis of the rate and extent of historical movement may be useless if excessive meander migration is a problem (as with meander Class F in Figure 11). Depending on the scale of the overlays, the amount of migration may be so small as to be undetectable or the overlays may be at such a small scale that the movement is not measurable.

Countermeasures to halt bank erosion or protect a physical feature within the floodplain can also have an impact on the usefulness of the overlays. These features should be identified prior to developing the overlays. Anomalous changes in the bend or bankline configuration or a major reduction in migration rates may suggest that bank protection is present, especially in areas where the bankline is not completely visible or on images with poor resolution.

Geologic features, such as clay plugs or rock outcrops, in the floodplain can also limit the usefulness of the overlays because they can have a significant influence on migration patterns. Bends can become distorted as they impinge on these features and localized bankline erosion rates may decrease significantly as these erosion resistant features become exposed in the bank. Where the channel encounters a geologic control or man-made feature, the channel may intersect the feature at a sharp or abrupt angle and migrate more rapidly down valley along the feature or become highly distorted. An example of this might be where a channel encounters geologic controls, bank protection, or levees that run parallel to the valley direction.

In some cases the channel may encounter a very localized outcrop or hardpoint in the bank creating an irregular bankline or causing the bend to deform around it. In these cases, determining the radius of the outside bankline of a bend may be very difficult. Since any evaluation of meander migration requires an assessment of, among other things, changes in bend radius, judgment must be used in determining the radius of the bend, and possibly the bankline, by defining it with a best-fit circle of known radius.

Where the channel makes a sharp or abrupt turn, mud flats or bars may develop along the outer bank in the upstream half of the bend, and the delineation of the outer bankline on a photo or map may be difficult. In this case, there are two methods of defining an approximate outer bankline radius. The first method is to identify the radius of the inner bankline by inscribing a best-fit circle on it and then determining the average channel width at the crossings in the reach. Then, the user can add 1.5 to 2 average channel widths to the inner bankline circle to define the outer bankline radius. Once this is accomplished, the user will need to evaluate how well the estimated outer bankline fits relative to the actual channel position, to similar bends that may be located in the reach, and to other features along the channel at the bend.

The second method requires the use of the edge of water at the outer bankline of the channel on the photo or map. This should provide a relatively close approximation of the outer bankline radius of curvature. Although both of these methods can contain significant error, they may provide the only reasonable approximation of the outer bankline and radius of curvature necessary to make a prediction of future bankline position.

In reaches where geologic controls are exposed predominantly in the bed of the channel, migration rates may dramatically increase because the channel bed is not adjustable, which may cause the channel to migrate rapidly across the feature. A fundamental assumption of the overlay techniques based on aerial photo or map comparison is that a time period sufficient to "average out" such anomalies will be available, making the historic meander rates a reasonable key to the future.

GIS PREDICTOR RESULTS

The photo comparison methodology was tested by applying the ArcView-based measurement (Data Logger) and extrapolation (Channel Migration Predictor) tools to 50 sites. The Brice data set was used because banklines for three points in time (two from the original Brice data and one from recent aerial photography that was obtained as part of this project) were required to test the accuracy of the predictions. The first two bankline locations were used to predict the recent bankline location for comparison with the bankline on the recent photography. Sites that were classified as C sites (single phase meandering channels with point bars and wider bends) were selected because this classification included the greatest number of active, freely meandering bends with three time periods of coverage.

Of the 50 sites, seven were excluded based on the same rationale that should be used in deciding whether the method should be applied to any specific bend. In several cases, the time interval between the first two banklines was 10 to 12 years whereas the second time interval (from the second bankline observation to the recent aerial photograph) was 25 to 33 years. Since the methodology is essentially an extrapolation of past movement, the extrapolation should not be significantly longer than the observed time period. Other sites were excluded due to close proximity to a major tributary, sand/gravel mining, and natural bend cutoffs. In one case, the bend was partially revetted and both upstream and downstream bends were completely revetted between the time of the second bankline observation and the recent aerial photo. The results of this evaluation are, therefore, representative of 43 relatively freely meandering bends. The average time intervals for the remaining 43 bends were 27 years between the first and second bankline observations and 26 years between the second and third bankline observations.

Using the ArcView measurement tool, the bend radius and center location were measured for each of the three bankline locations. Typically, the first bankline was from the 1930s, the second from the 1960s and the third from the 1990s. The prediction tool was then used to predict the radius and center location for the third time period. Since the movement of the bankline is the item of interest, the evaluation focused on the accuracy of predicting bankline location. Four parameters were measured and compared for each of the 43 bends: (1) bend radius; (2) magnitude of maximum bankline movement; (3) direction of maximum bankline movement; and (4) maximum difference between the predicted and observed bankline at any

point along the bend. These four parameters represent different types of error in the prediction. The method may accurately predict direction of maximum migration, but could over- or under-predict the amount of movement. If both direction and maximum migration are predicted well, but the radius is not accurate, then the error in radius would result in some error in the bankline prediction at other locations along the bend.

These measurements are illustrated in Figure 43, which depicts a bend on the Tombigbee River near Amory, Mississippi. The banklines are from the 1937 and 1969 Brice data set and the 1996 aerial photograph. The 32 year time period (1937-1969) is used to predict the movement over the subsequent 27 years (1969-1996). The 1937 channel is shaded and flow is from left to right. The two arrows show the magnitude and direction of the maximum bend movement between 1969 and 1996 for the predicted and actual bank location. The bend radius of the actual 1996 outer bank location was measured but is not shown in this figure to improve clarity. In addition to the predicted 1996 circle, the predicted upstream and downstream 1996 banklines were sketched based on past movement. Finally, the maximum difference between any point along the actual and predicted 1996 banklines was measured. In this case, the maximum difference occurs at the bend apex, although along the downstream limb of the bend similar amounts of difference occurs. For this site, the direction of bank movement was very accurately predicted. The radius was also well predicted, but the amount of bankline migration was under-predicted by approximately 50 percent. Overall, the prediction appears to be very reasonable and would alert a structure owner to potential problems with channel migration in this vicinity.

There is one other noteworthy feature illustrated in Figure 43, the extreme change in channel width that occurs between bankline observations. There is a slight increase in width between 1937 and 1969 and, at the apex, approximately a 70 percent increase in width between 1969 and 1996. Nearly 40 percent of the sites experienced channel width changes of greater than 30 percent (increase or decrease) between the second bankline and the recent aerial photograph (the average change in channel width was 32 percent). On average, there was a 10 percent increase in channel width. If sites that experienced a 50 percent or greater change in width had been eliminated from the test of predictor results, an additional 10 sites would have had to be eliminated.

As shown in Figure 43, the direction of maximum bank migration was measured for the predicted and actual banklines. The difference between the predicted and actual bankline migration directions is shown in Figure 44 as a bar chart and as a cumulative percentage. Fifteen of the 43 bends (35 percent) showed predicted and observed maximum bank migration within 10 degrees. More than half (60 percent) of the maximum bank erosion was within 20 degrees of the observed direction. Three of the bends had bank erosion direction greater than 40 degrees. It should be noted that at this level of error (45 degrees or more), one would be essentially predicting greater down-valley movement (translation) when the bank is actually eroding more across-valley (extension) or vice versa. A 90 degree difference would be predicting one mode of movement when the bank is actually migrating in the other mode. None of the 43 test bends showed more than 70 degrees difference between the actual and predicted direction of maximum bank erosion. In two cases the migration was actually in the up-valley direction and this direction was predicted by the methodology.

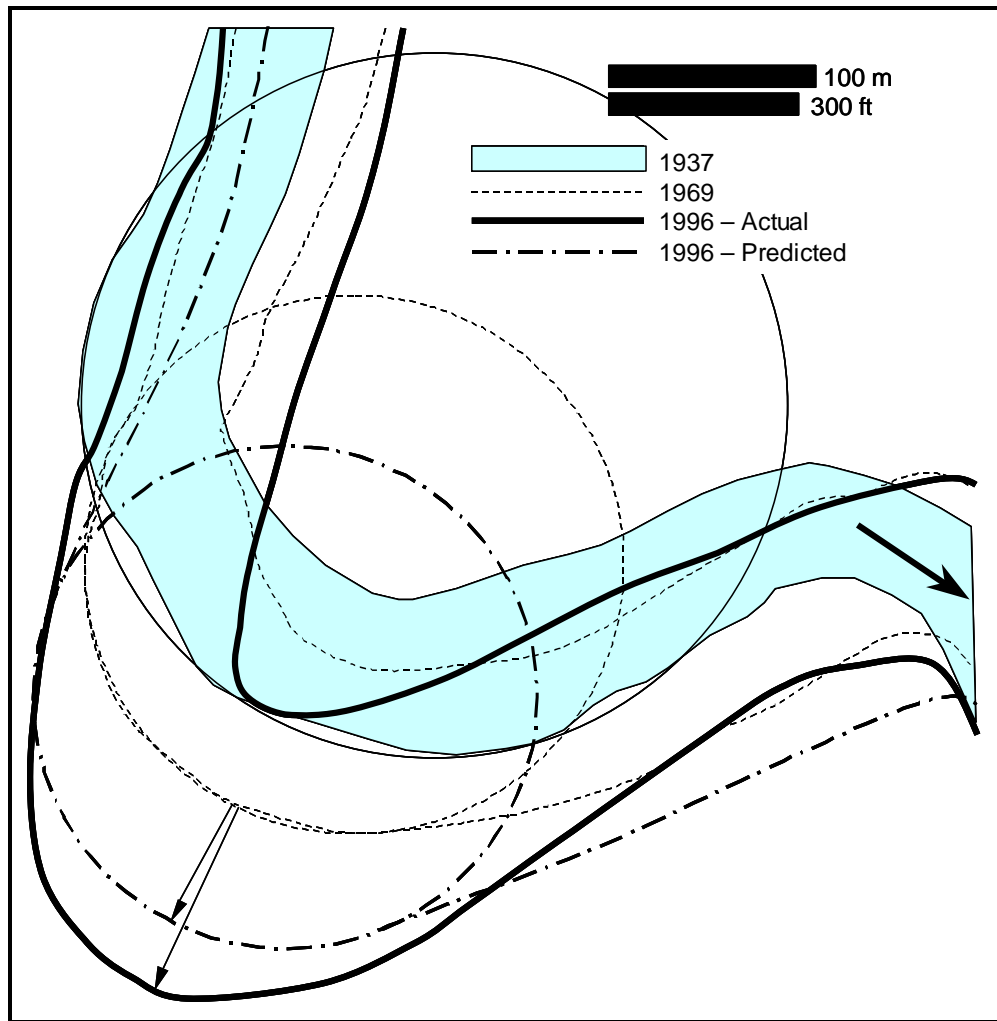

Figure 43. Channel migration comparison for the Tombigbee River near Amory, MS.

Figure 45 shows a comparison of predicted versus observed bend radius for the 43 test bends. In addition to the data, perfect agreement, ± 25 , ± 50 and $+ 100$ percent error lines are included. Fifty percent of predicted bend radii (22 of the 43 bends) were within 15 percent of the actual bend radii, and 65 percent (28 of 43) of the predicted bend radii were within 25 percent of the actual bend radii. On average, the predicted bend radii were approximately 5 percent smaller than actually observed. This could relate to the fact that, on average, channel width increased by 10 percent between the second and third bankline observations.

Figure 45 also shows predicted and observed maximum bank migration magnitudes. Each of the channel bends were actively migrating. In one extreme case, a bend migrated down valley nearly 2,950 feet (900 m) in 24 years. The predicted down valley migration for this bend was nearly 3,610 feet (1,100 m). On average, the maximum predicted bank erosion was 22 percent greater than observed. This is probably due to the fact that maximum possible underestimation of bank migration is 100 percent (zero migration predicted versus some

measurable amount). However, it is possible to overestimate bank migration by more than 100 percent (490 feet (150 m) of predicted migration versus 213 feet (65 m) of observed migration is an overestimation of 130 percent). In the cases where the amount of migration was significantly overestimated, the prediction still appeared quite reasonable. Seventy percent of the predicted bank migration amounts were within 50 percent of observed amounts and 42 percent of the bank migration amounts were within 25 percent of the observations.

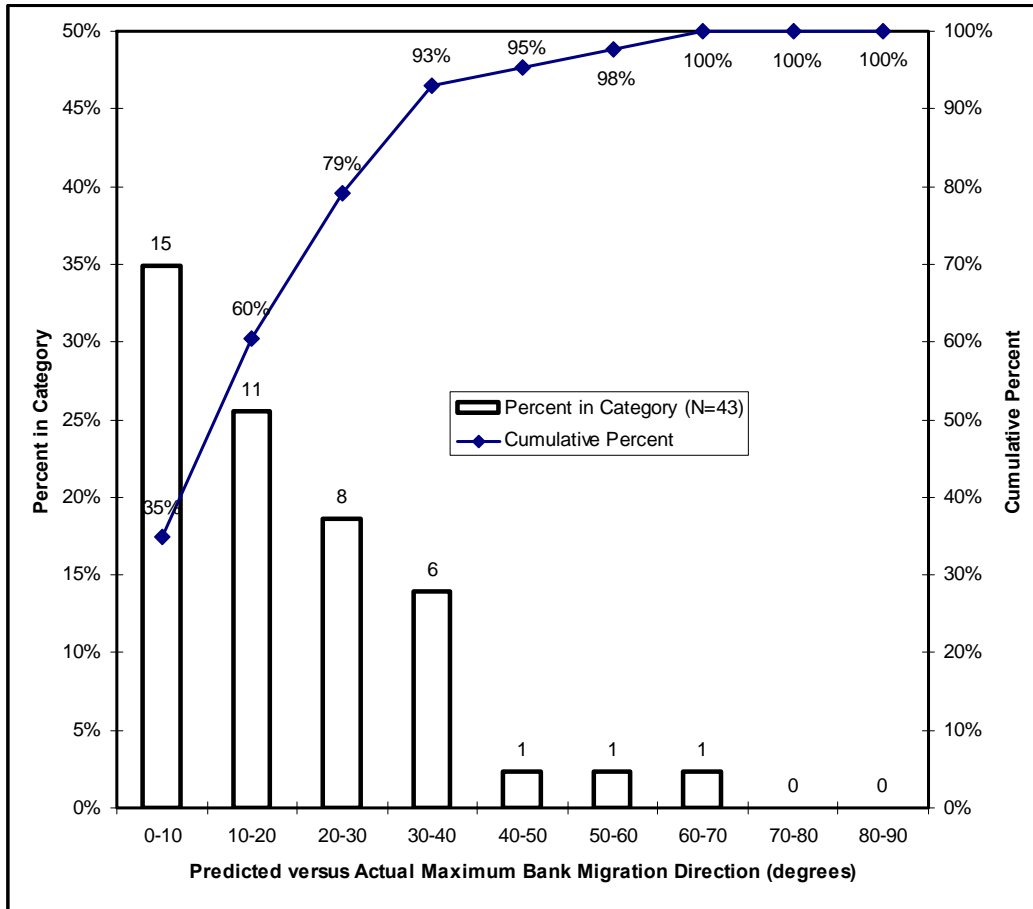

Figure 44. Predicted versus actual bank migration direction.

One way of interpreting Figure 45 is to compare the range of scatter to that of sediment transport calculations or measurements. This is a valid comparison because bank migration is related to erosion and sediment transport. In the test data set, the maximum range of scatter for bank migration is approximately 0.8 of a log scale and the bulk of the data fall within one-half a log scale. Sediment transport measurements and calculations can easily scatter over a full log scale (and often two log scales) for a given hydraulic condition (see 224, 225). This has led to the tongue-in-cheek observation that the "best" sediment transport estimate is zero, because the prediction is then "only" 100 percent off. Certainly there is a desire for prediction with greater accuracy, but given the complexity and variability of this process, the range of scatter in the test data is expected and the predictions are reasonable.

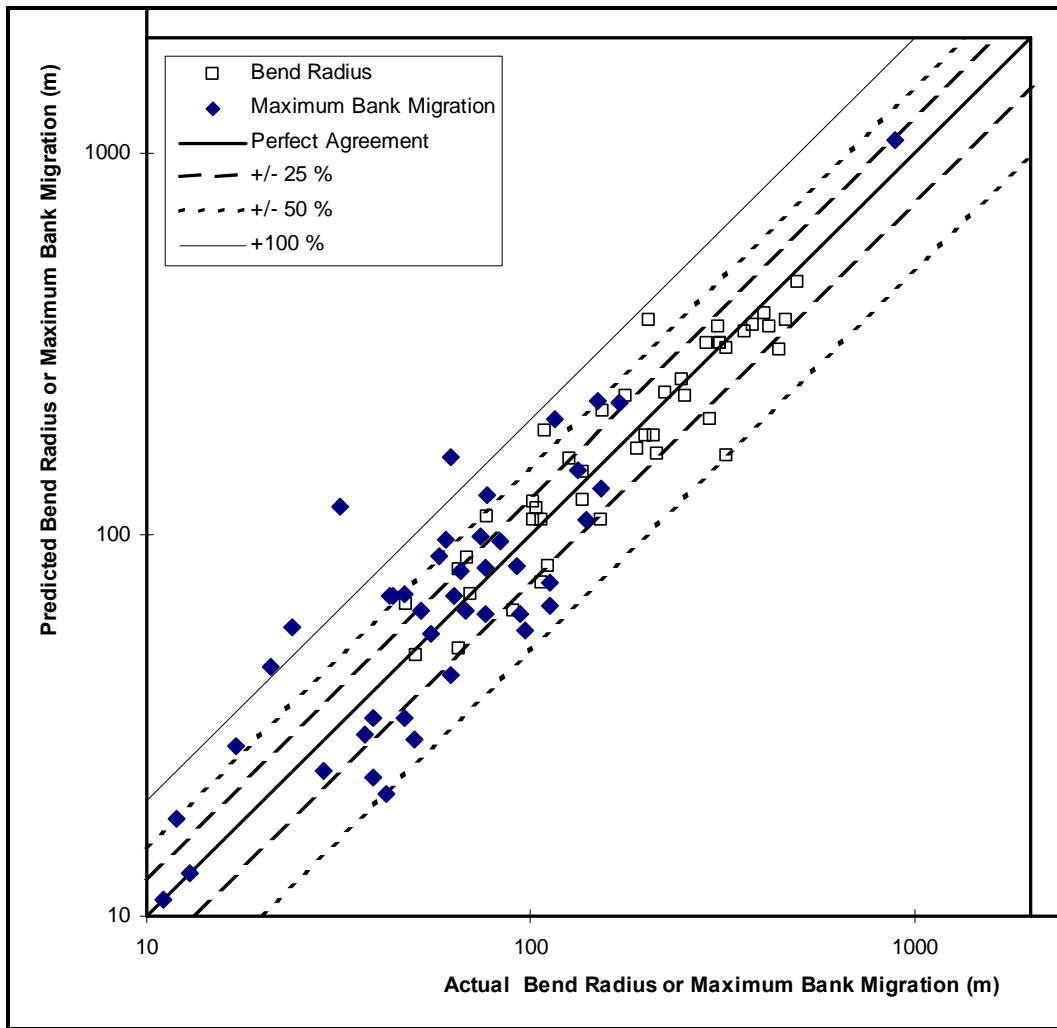

Figure 45. Predicted versus actual bend radius and bank migration magnitude.

Another way of assessing the accuracy of the predicted bank migration amounts is to compare the errors in bank migration to changes in channel width. A large absolute error in predicted channel migration is more likely for a large channel than a small channel. Figures 46 and 47 show errors in channel bank migration relative to the channel width as both incremental and cumulative percentages. The channel width used for normalization was the width for the intermediate time period. For comparison, the change in channel width between the second and third time periods is also shown. These figures illustrate that error in migration (defined as difference between the length of the arrows shown in Figure 43) is most frequently within 20 percent of channel width. These errors are distributed similarly to the change in channel width. In other words, errors in predicting bankline location are comparable to the changes expected in channel width. Given that the predictions are, on average, for a 26 year time period the amount of error in migration (or change in width) is on the order of one percent of the channel width per year.

Figures 46 and 47 also show the maximum difference in bankline at any location along the bend. This is the most extreme measure of error for the methodology. Even if the maximum bank erosion amount and direction were predicted accurately, some point along the actual bankline could deviate from the prediction. Although these errors are greater than width variability, they are still similarly distributed.

In summary, the evaluation of 43 active, freely meandering bends indicates that: (1) bank erosion direction is predicted within 0 to 30 degrees in nearly 80 percent of the cases; (2) for nearly 60 percent of the cases bank migration magnitude is predicted within an accuracy of one percent of channel width per year over the time period covered by the prediction; and (3) this level of accuracy is comparable to the variability of channel width. A qualitative assessment of the procedure indicates that the majority of the predictions were reasonable and compared well with the actual channel migration.

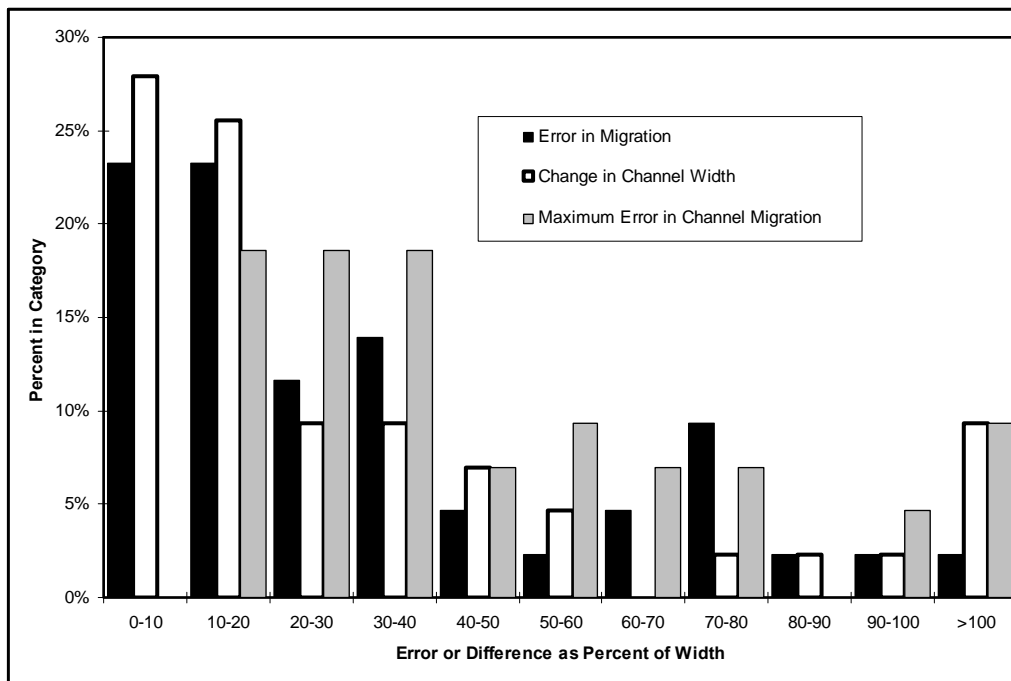

Figure 46. Error in bank migration as a percent of channel width (incremental percent).

REGRESSION ANALYSIS

The rates of bend expansion, extension, and translation were computed for each location and each time period. The bank line data are generally from the 1930s, 1960s, and 1990s. Using the first and second, second and third, and first and third time periods resulted an average intervals of 27, 26, and 56 years, respectively. The data were grouped using the Modified Brice Classification. The A, B1, B2, and C classes included 89, 249, 408, and 915 data points in the Brice data set, respectively. Standard single variable and multi-variable regression techniques were applied in an attempt to obtain regression relationships for predicting change in component variables that describe meander migration.

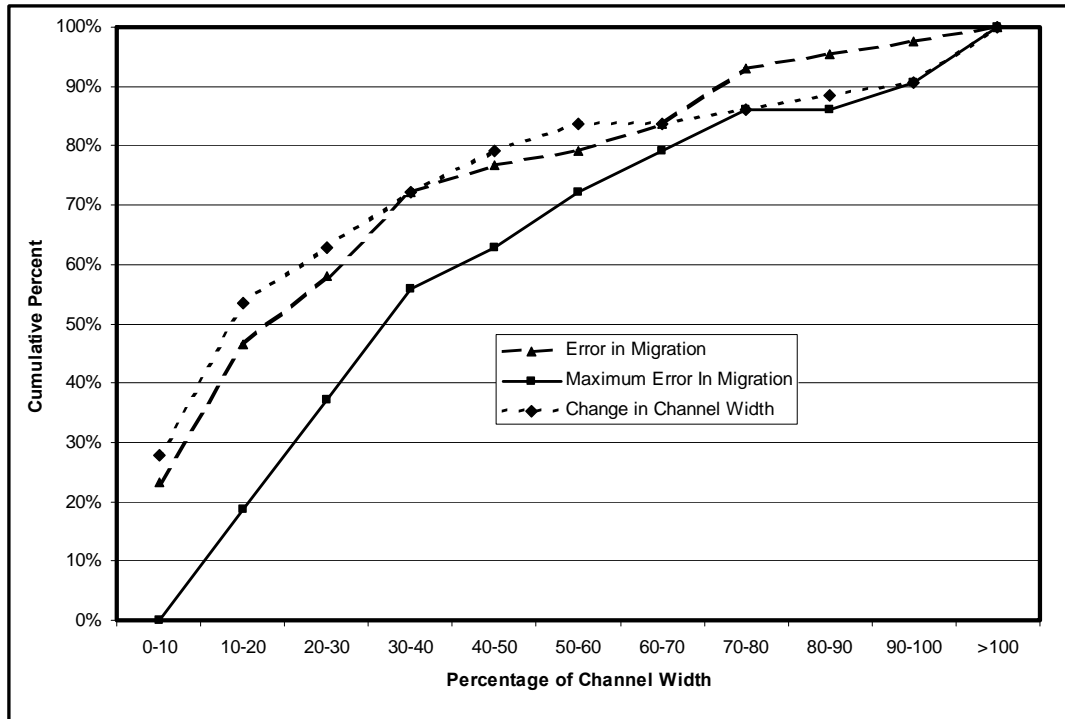

Figure 47. Error in bank migration relative to channel width (cumulative percent).

Expansion

One mode of meander migration is radius expansion. Bends can either expand or contract (negative expansion). Figure 48 shows the ratio of bend radius of curvature at the end of a time period to radius of curvature at the beginning of the time period plotted versus initial radius of curvature over width (R_{ci}/W_i , bend tightness). Although there are expanding and contracting bends throughout the range of R_{ci}/W_i , Figure 48 shows that tighter bends tend to expand ($R_{cn}/R_{ci} > 1$) and longer bends tend to contract ($R_{cn}/R_{ci} < 1$) by reducing their radius. The data set is dominated by a cluster of data points with $1 < R_{ci}/W_i < 3$ centered on $R_{cn}/R_{ci} = 1$. R_{cn}/R_{ci} equal to one indicates that the bend did not change its radius of curvature over the time interval.

An equation that appears to describe expansion is:

$$\frac{dR}{dt} = a \left(1 - \frac{R_c}{bW} \right) R_c$$

This equation accounts for the trend that, as the radius changes, the value of R_c/W changes and, therefore, the rate of expansion should change. When integrated, the solution to this equation is:

$$R_{cn} = \frac{R_{ci}}{\frac{R_{ci}}{bW_i} + \left(1 - \frac{R_{ci}}{bW_i} \right) \exp(at)}$$

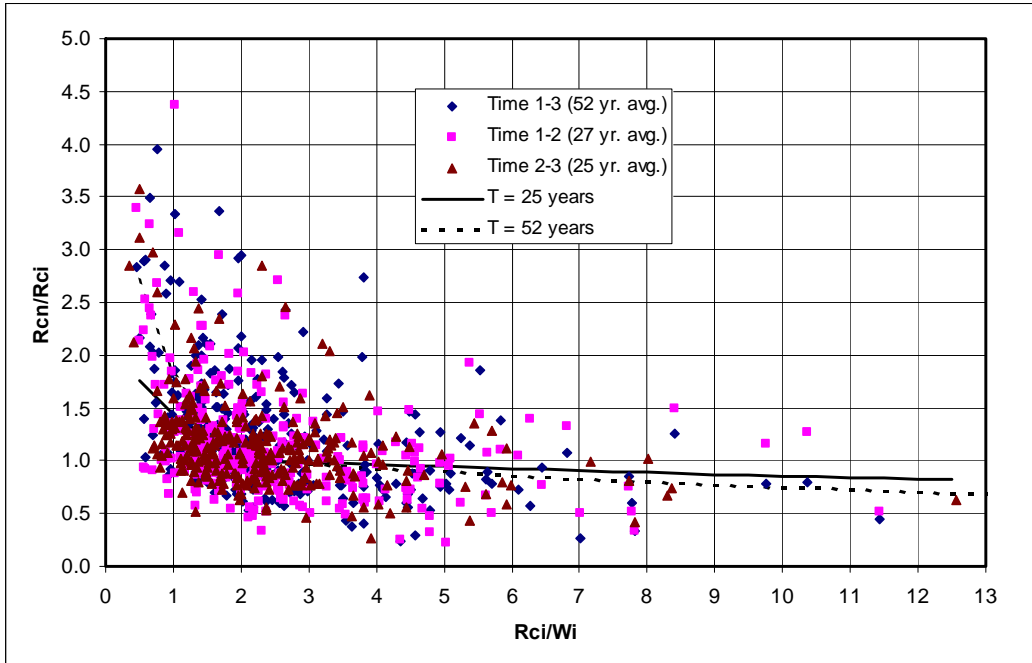

Figure 48. Change in Radius of Curvature versus Radius of Curvature/Width (C Sites).

The coefficients "a" and "b" were fit to the data of Figure 48. At $t=0$ $R_{cn} = R_{ci}$ and at $t = \infty$ the ultimate radius is equal to bW_i . When a bend has an $R_{ci}/W_i = "b"$, then the bend does not change its radius. For a bend that starts at an $R_{ci}/W_i \neq "b"$, as time progresses, R_{ci}/W_i approaches "b" and the rate of change approaches zero. Note that the value of "b" has physical meaning. The coefficient "b" is the ratio of bend radius to bend width that is most stable, at least in terms of expansion. This does not, however, mean that the bend is not migrating through extension or translation.

The best fit results come from using different values of "a" for R_{ci}/W_i less than "b" and for R_{ci}/W_i greater and "b." From the C Site data shown in Figure 48, "b" = 2.2, $a^+ = -0.033$ and $a^- = -0.0019$. Plots of this equation for 25 and 52 years are shown in Figure 48. The equation produces an $R^2 = 0.70$ for the future radius of curvature, R_{cn} . While this may appear to be a good fit, most of the correlation is due to the fact that the existing radius (R_{ci}) is a fairly good estimate of the future radius ($R^2 = 0.65$). A more meaningful way to compute R^2 for this equation is to see how well the ratio of R_{cn} to R_{ci} is predicted. Although the existing radius may be a good estimate of the future radius, this assumption gives the equation $R_{cn}/R_{ci} = 1.0$ radius, the equation yields an $R^2 = 0.23$, indicating that while there is a trend (which is evident in Figure 48), there is significant scatter around the equation.

As shown in Figure 48, the data set is dominated by a cluster of data points with $1 < R_{ci}/W_i < 3$ centered on $R_{cn}/R_{ci} = 1$. Visually, it appears that there should be a steeper slope for $R_{ci}/W_i < 2$. In an attempt to put greater weight on the low values of R_{ci}/W_i , the data were grouped by time interval and by R_{ci}/W_i (Figure 49) and the equation was fit with the grouped data. The grouped data show the trend of the data much more clearly and put equal weight on data over the entire range. The data follow the expected trends of greater change outside an $R_{ci}/W_i = 3$ and

greater change for longer time periods. The R^2 for this data is 0.96, although this is really only a measure of how well the equation fits the mean trend of the data. The equation coefficients for Figure 49 are "b" = 2.6, a^+ = -0.060 and a^- = -0.0025 as compared with "b" = 2.2, a^+ = -0.033 and a^- = -0.0019 from the original data. The data show a trend for expanding radius for tight bends, contracting radius for long bends, and relative stability in radius for bends with R/W equal to 3. Attempts to improve the predicted radius by including discharge, unit discharge, slope, stream power, unit-stream power, grain size and percent silt-clay did not yield increased R^2 .

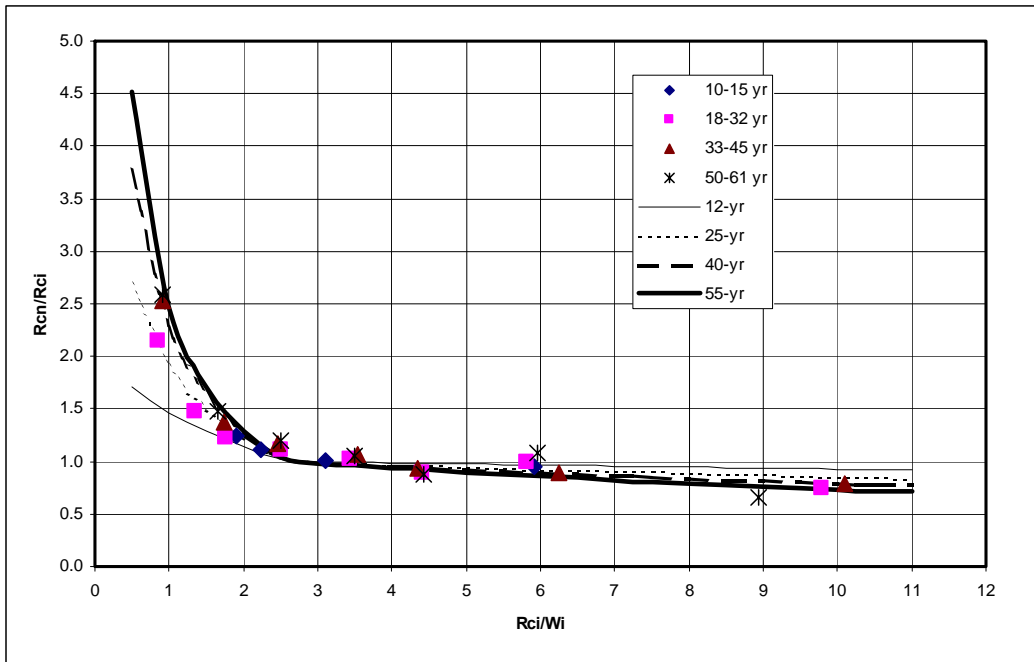

Figure 49. Change in Radius of Curvature versus Radius of Curvature/Width (C Sites grouped data).

Translation and Extension

The two other modes of meander migration are translation and extension. These modes may also be positive or negative depending on the direction of movement, but they tend to be positive. Statistically significant relationships for extension and translation were also not forthcoming. Figure 50 shows the C site data from Figure 17 comparing bank migration (the vector sum of expansion, extension and translation) to channel width. There is a very weak correlation between bank migration and width, although the data scatter over 2.5 log scales. Although the "best fit" line has a slope of 0.47, the data appear to follow a steeper trend. Multiple regression did not improve the value of R^2 . The variables included in the multiple regression were channel width, channel slope, average annual unit discharge, average peak unit discharge, stream power, bed material size, bank material percent silt-clay and radius of curvature. The primary variable appeared to be width, although at a very low correlation.

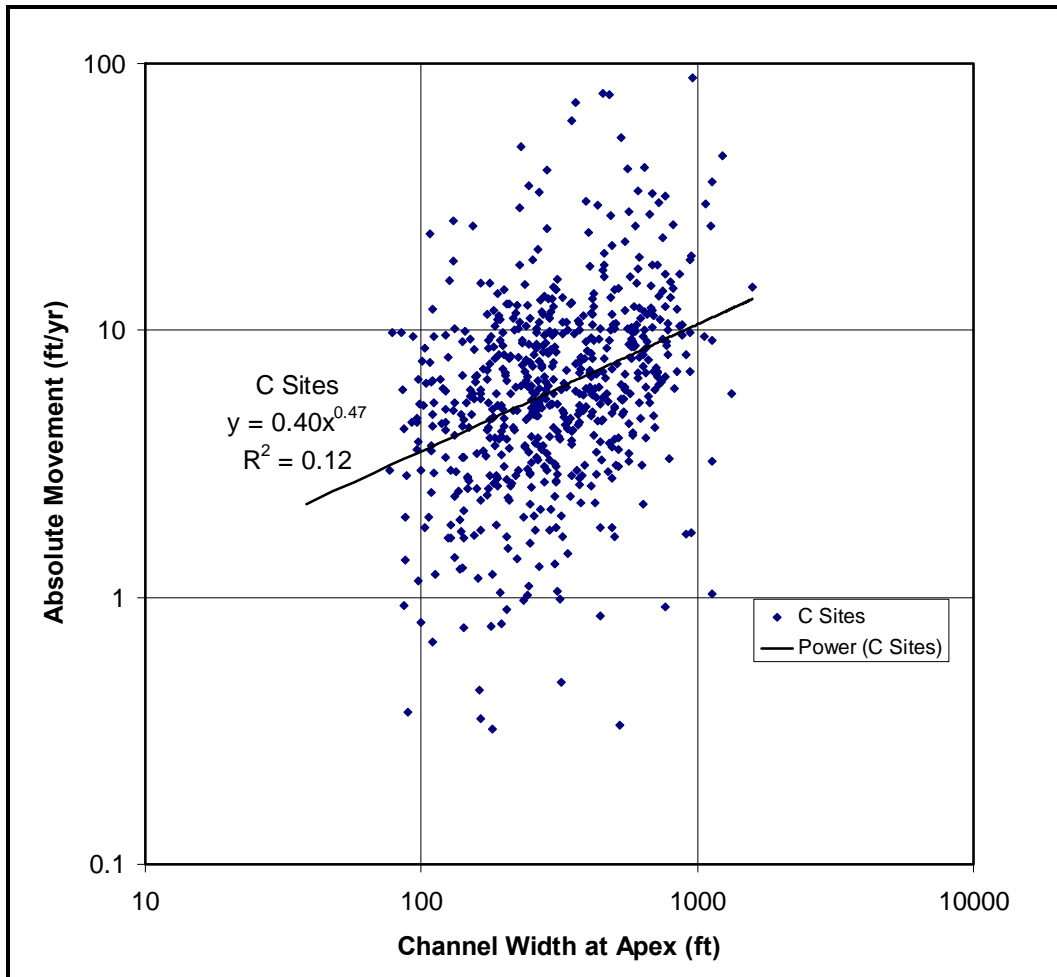

Figure 50. Bank Erosion Rate versus Channel Width.

Channel width appears to be an important variable in predicting all the modes of migration. Nanson and Hickin (91) attempted to use R/W to predict erosion rates. Cherry et al. (48) showed a weak correlation between average bank erosion rates and width. However, as illustrated in Figure 51, channel width is a river property that varies considerably over time. Figure 51 shows the C site data, where for each bend the channel widths from the 1990s are plotted on the Y-axis versus the 1960s data on the X-axis (as well as the 1960s data plotted versus the 1930s data). If a relationship for predicting future meander migration is developed using channel width as a variable, then the large variability in channel width (from one time period to the next) will only confound the prediction. As shown in Figure 51, width values scatter as much as an entire log scale and generally over half a log scale. For example, some channels that started as 200 feet (61 m) wide were less than 100 feet (30 m) wide 30 years later and other 200 feet (61 m) wide channels were greater than 800 feet (244 m) wide after 30 years. Change in channel width has a direct impact on bank location, but it is not truly meander migration as defined for this project. Therefore, any attempt at predicting meander migration, whether empirically, through physical modeling, or by photo comparison, is subject to a large degree of uncertainty based on the fact that width varies considerably over time.

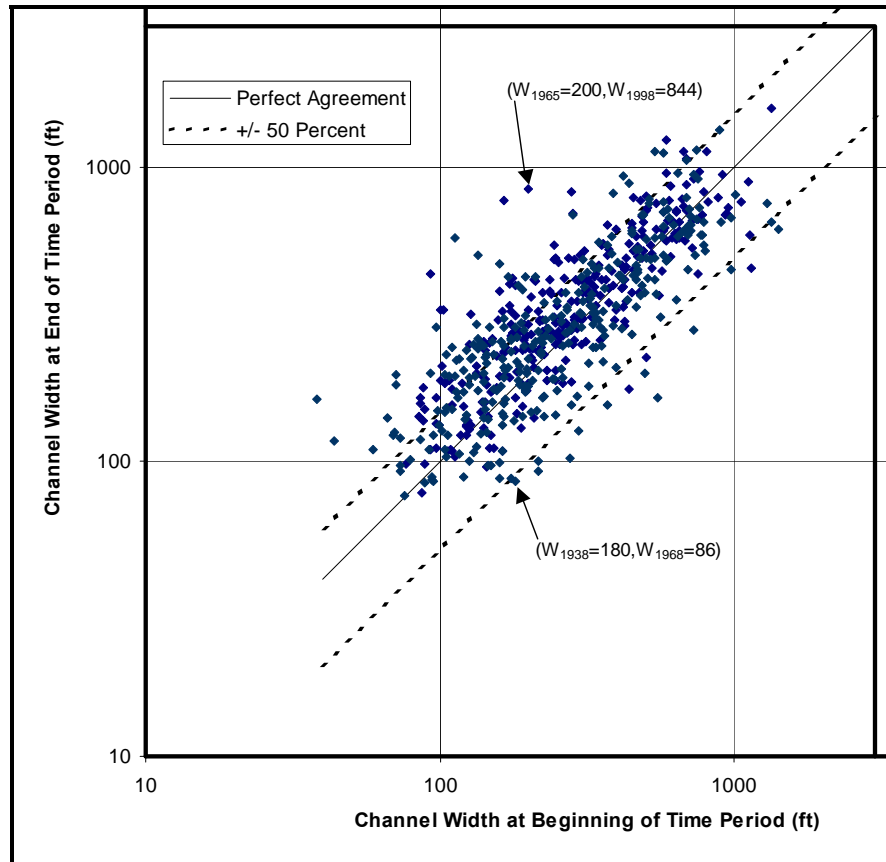

Figure 51. Change in Channel Width at C sites.

EVALUATION AND TESTING OF THE METHODOLOGY

The project scope included two tasks to evaluate and test the methodology. Task 6 involved internal testing by the Research Team and Task 8 required providing the methodology to at least five State DOTs for their independent assessment and report on the results. The methodologies and the Handbook were revised following each task based on results and recommendations from individuals and agencies involved. This section describes the Beta test approach, the results reported, and revisions made based on recommendations from the evaluators.

Overview

A Beta test of the methodology for evaluating and predicting meander migration using aerial photo and map comparison techniques described in the Handbook was conducted in two phases: September and October 2001 (internal testing) and August – October 2002 (State Beta testing). The Task 6 internal test was conducted by three different evaluators that included an undergraduate geology student from the University of Nottingham, UK, a water resources project engineer (P.E.) employed by Ayres Associates, Inc., and a graduate degreed civil engineer (P.E.) from Mussetter Engineering, Inc. (MEI). Dr. Colin Thorne (UK) and Dr. Robert Mussetter, P.E, also reviewed the Handbook for consistency and accuracy. The Task 8 State Beta test participants are shown in Table 8.

State	Contact
Alabama	Tom Flournoy, Bridge Hydraulic Engineer
Alaska	Mark Miles, State Hydraulic Engineer
California	Bill Lindsey, Structures Hydraulics (Kevin Flora)
Maryland	Andy Kosicki, Bridge Hydraulic Engineer (Stan Davis)
Nevada	Amir Soltani, Chief Hydraulic Engineer (Ron Schilling)
Austin, TX	Mike Kelly, Watershed Protection
Georgia	Tom Scruggs, Geotechnical Engineer (Jason Duley)
Wyoming	Bill Bailey, Hydraulic Engineer

All evaluators were provided with maps and aerial photos and basic instructions on three techniques to be tested. The first technique requested that the evaluators conduct a meander migration evaluation and make a prediction of future channel position for a site on the Sacramento River using historic survey maps and paper copies of aerial photographs. The second technique requested that the evaluators use digital aerial photography to assess historic meander migration and make predictions on the future channel position for a site on the Minnesota River using Microsoft PowerPoint or some other graphics software. The third technique requested that the evaluators use the ArcView-based Channel Migration Predictor tool developed for this project to predict the future channel position of the Sacramento and Minnesota River sites.

Once the Beta test was completed the results of each evaluator were examined and any problems or discrepancies were discussed with each evaluator. The results from each evaluator were compared with the results from the other evaluators to define any errors or inconsistencies in the methodology or determine if clarification in the techniques needed to be made. Each evaluator was requested to provide written comments on the usability of the methodology as part of the Beta test.

Evaluation Procedure

The evaluators tested the methodology set forth in the Handbook using the three techniques described therein: (1) the simple overlay technique; (2) the computer assisted technique; and (3) the Channel Migration Predictor technique.

Simple Overlay Technique

The site that was evaluated using the simple overlay technique consisted of three bends on the Sacramento River at Sidds Landing, California (Figure 52). The river is bound on the west side (right bank) by a levee that is unprotected along much of the reach. The three bends in this reach of the river are actively migrating downstream and pose a significant threat to the levee.

Each evaluator was given a set of paper copies of historic maps and aerial photographs to conduct the evaluation of this site. The maps consist of a hydrographic and topographic survey of the river and meanderbelt conducted in 1937 by the U.S. Army Corps of Engineers and drawn at a scale of 1 inch = 400 feet. Paper copies of 1972 aerial photographs of the site, compiled by California Department of Water Resources (CDWR) at an optimal scale of 1 inch = 400 feet,

were made available to the evaluators. An enlarged black and white print (optimal scale = 1:27,000) of a NAPP (National Aerial Photography Program) aerial photo taken of the site in 1998 was obtained from the USDA Farm Service Agency Aerial Photo Field Office.

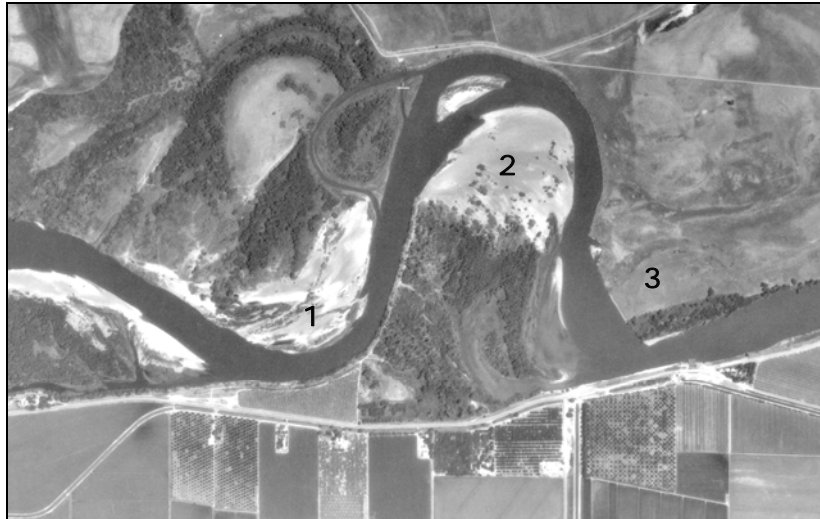

Figure 52. Beta test site on the Sacramento River at Sidds Landing, California.
Flow is left (north) to right (south).

The first step in the evaluation of this technique required that the evaluators register all the maps and aerial photographs together. Registration points common to all three sets of maps/photos needed to be identified first and then the maps and photos needed to be registered to a base map or photo by enlarging or reducing the maps and photos. The base map or photo to which the other maps and photos were registered was selected by the evaluator. The evaluator was then required to determine the approximate scale of the base.

Once the maps and photos were registered to each other and to a common scale, the evaluator was required to delineate the banklines of the river for each year within the given reach. The banklines and registration points were traced onto transparent Mylar. Delineation of the banklines is somewhat subjective and often requires sound judgment based on observed conditions and knowledge of features common to rivers. In some cases, delineation of the bankline can be difficult especially where there is no well-defined scarp or vegetation line. In this case, the evaluators required some assistance in defining the banklines, particularly where the outer bank was gradually sloped or very irregular and where there were large, active point bars present.

After the banklines for each data set were traced onto transparent Mylar sheets, they were overlain together and compared with regard to historic channel migration. This allowed the evaluators to see how the bends migrated and to assess outer bank retreat and inner bank growth over time.

The next step in this technique required the evaluators to inscribe a circle along the outer bank of each bend for each year (Figure 53). The position of the bend centroid (center point of the inscribed circle) was defined on the tracings and the radius of the circle (radius of curvature) at each bend for all years was noted (Figure 54).

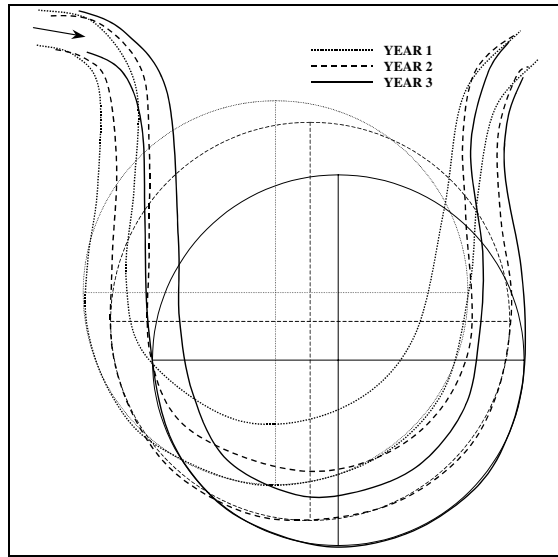

Figure 53. Banklines and circles inscribed on outer bankline positions for a hypothetical channel at 3 different years.

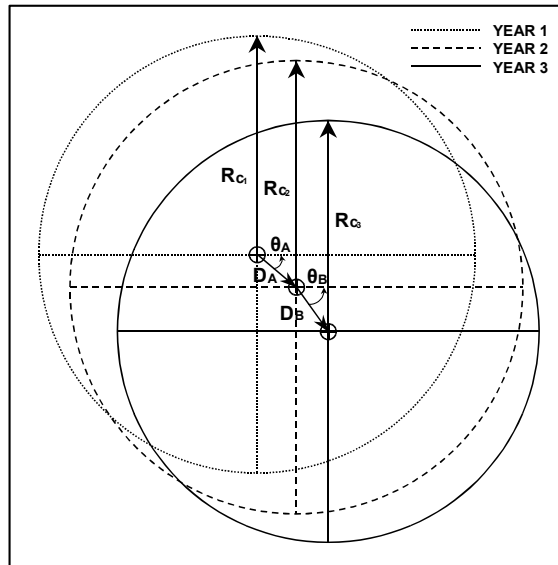

Figure 54. Diagram defining the outer bank radius of curvature in Years 1, 2, and 3, and the amount (D_A and D_B) and direction (θ_A and θ_B) of migration of the bend centroid during time periods A and B for a hypothetical bend.

Once the circles defining each bend for all years had been delineated, the evaluator used the changes in the radius of curvature and bend centroid position to predict the position and radius of the bend for some year in the future. In the case of the Sacramento River site, the position of the centroids and the radii of the three bends were predicted for the year 2028.

Computer Assisted (PowerPoint) Overlay Technique

The second method of predicting meander migration allows the evaluator to use a relatively common graphical editing software package, in this case Microsoft's PowerPoint, to conduct the meander migration assessment and prediction. The steps used in the methodology are the same as those used in the simple overlay technique described in the previous section.

The site used for this technique is located on the Minnesota River at Judson, Minnesota (Figure 55). The site consists of five relatively unconfined bends actively migrating across and down valley. The evaluators were provided with electronically scanned aerial photographs from 1950 and 1968. The evaluators were required to download, via the Internet, the most up-to-date image (1991) from Microsoft's TerraServer Web site. The scanned images are of unrectified aerial photos whereas the TerraServer image is rectified and georeferenced. The images were compiled in PowerPoint and then common registration points were located, banklines delineated, and circles inscribed along the outer bank of each bend for each year. Once this was done, the banklines and circles for each year were overlain using the common registration points. The unrectified images could be manipulated so that all the registration points closely matched those of the TerraServer Image using the sizing attributes of PowerPoint.



Figure 55. Beta test site on the Minnesota River at Judson, Minnesota. Flow is left (west) to right (east).

The banklines were overlain in a separate file from the bend circles for later comparison and assessment. Once the bend circles were overlain and the bend centroids delineated, a scale was placed on the overlays based on the georeferenced Terraserver photo, which has a known scale. After placing a scale bar on the bend circle overlay, the image was printed out so that the evaluator could use the bar scale to determine the bend radii, the migration distances between centroids, and the angle of migration for each bend in each year. From this information, the evaluators were able to determine the radius, angle of migration, and migration distance for each bend at some point in the future, in this case the year 2021.

ArcView-Based Bend Measurement and Migration Predictor Technique

This method required the evaluators to use the ArcView-based Bend Measurement tool and the Channel Migration Predictor developed for this project to conduct the analysis of the meander bends for both the Sacramento River and the Minnesota River sites. In both cases, the evaluators were given electronic files with the georeferenced banklines for all years for both sites. The evaluators were required to fit circles to the bends using the method described in the Handbook. This method required the user to place regularly spaced points around a bend to define the bend shape. The program then fits a circle to the bend points and provides the user with the radius and centroid location. This is done for all bends in all years. Once this is accomplished, the Channel Migration Predictor uses the data to delineate a circle that defines the given bend for a user-defined year in the future.

Testing Results

Results of Beta testing of the meander prediction methodologies are compiled in Appendix C as follows:

- Table C1 – Simple Overlay: Sacramento River Site
- Table C2 – ArcView: Sacramento River Site
- Table C3 – Computer Assisted: Minnesota River Site
- Table C4 – ArcView: Minnesota River Site
- Table C5 – Summary of Beta Test Results

Simple Overlay – Sacramento River Site

Although there were differences in the magnitude of the predicted migration distances and the radii of the bends for the year 2028 among the evaluators (Table C1), the evaluators made similar predictions of the direction and extent of migration. The differences in the predicted bend radius of curvature and migration distance among the evaluators was attributed to differences in judgment in delineating the banklines and fitting a circle to the outer bank, both of which have a major influence on the radius and centroid position of the predicted bend. However, each evaluator did come to the same conclusion with regard to the relative speed of migration and the general change in the radius of each bend as well as the threat to the west (right) bank levee posed by continued meander migration.

Computer Assisted – Minnesota River Site

Table C3 provides a comparison of the results of this technique for each evaluator. Again, there are difference among the evaluators in measuring migration distance and radii for each bend, which can be explained by differences in judgement in delineating the banklines and fitting the outer bank circles. However, an examination of the results indicates that the differences in measurement among the evaluators are generally smaller than with the simple overlay technique, suggesting that the use of a graphical editing software package may be more accurate because the evaluators are able to more accurately delineate the banklines. The greater accuracy in delineating the banklines may be attributed to the ability to acquire images with greater resolution, the evaluators ability to freely zoom in on the images, and the fact that the images can be printed at a usable working scale.

ArcView Based Measurement and Prediction

Tables C2 and C4 summarize the results of the ArcView analysis of the Sacramento River and Minnesota River sites. Differences in measurement and prediction indicated that describing a bend by fitting points to the outer bankline in the Channel Migration Predictor is also somewhat subjective. However, the differences in the results among the evaluators are considerably smaller than in the previous two methods. The smaller discrepancies among the evaluators is attributed to the fact that each evaluator used the same banklines and that redefining the fitted circle was relatively easy if the user was not satisfied with the fit.

Statistical Analysis of Test Results

The Beta test evaluation provided useful comments and recommendations on the Handbook and on the methodology. Since the evaluation included numerous measurements and predictions of bend properties, the results compiled in Appendix C were also used to evaluate whether consistent measurements were made by the various Beta testers and whether consistent measurements were made using the various measurement techniques.

Figure 56 shows a comparison of the average bend radius measurements and predictions for each of the bends in the Beta tests. The simple overlay and computer assisted results are plotted versus the ArcView results. The data show that the two "manual" techniques produce average bend radius measurements and predictions typically within 20 percent of the ArcView tools. There are twice as many measurements as predictions because the methodology requires two measurements of bend radius to make one prediction of bend radius. The two sites provide a range of measured bend radius from approximately 500 ft to over 2,000 ft (152 m to 610 m).

Similar results are produced for migration distance when the simple overlay and computer assisted results are compared with the ArcView results (Figure 57). As with the bend radius, the two manual techniques produce average migration distance measurements and predictions typically within 20 percent of the ArcView tools. The two sites provide a wide range of migration distances from less than 100 feet (30 m) (Minnesota River) to over 2,000 feet (610 m) (Sacramento River). This shows that consistent results are obtained using the three techniques for a range of bend sizes and rates of movement.

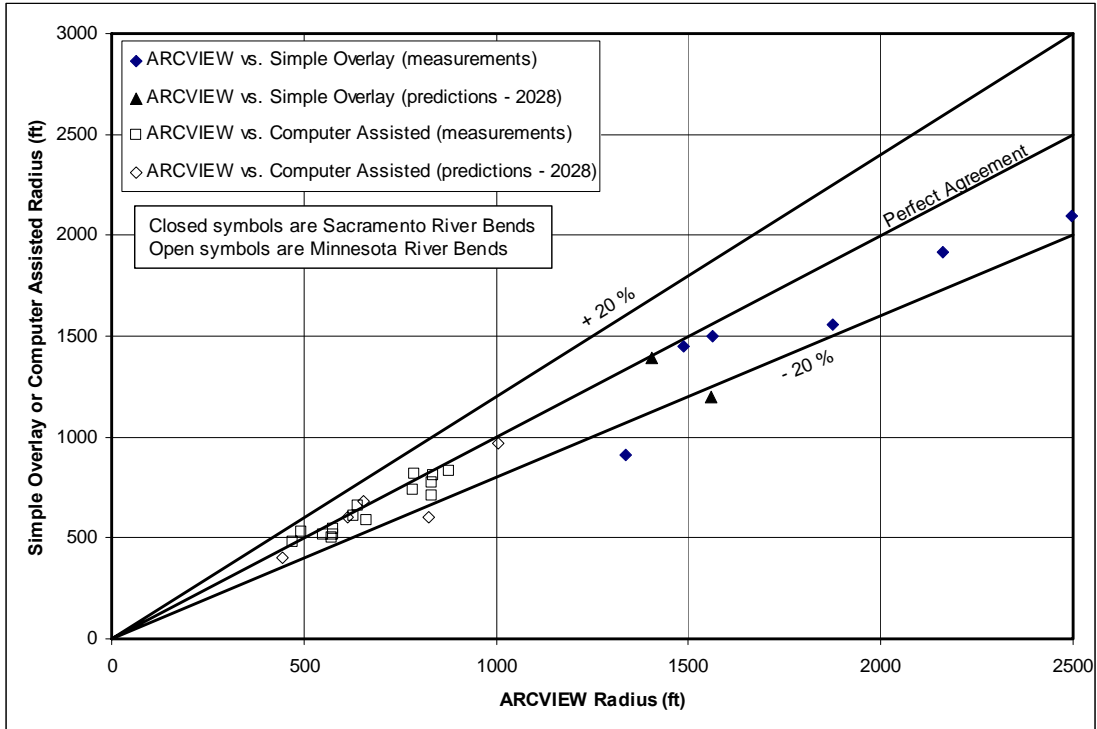

Figure 56. Comparison of bend radius measurements.

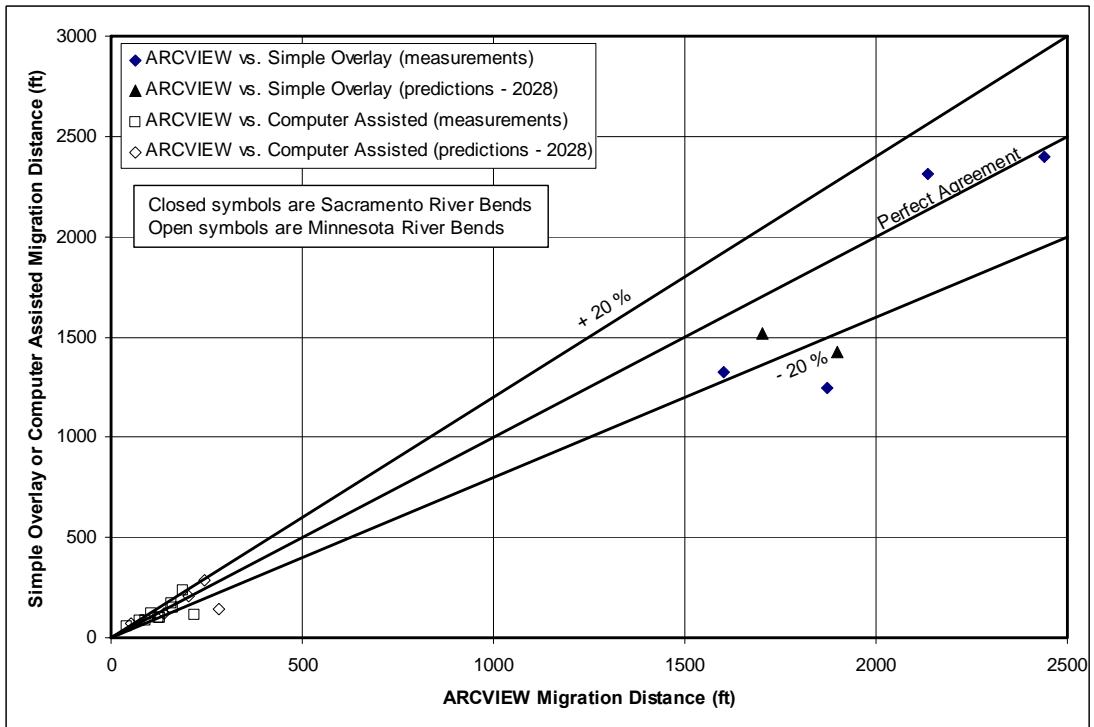

Figure 57. Comparison of migration distance measurements.

Figures 56 and 57 indicate that generally consistent results (within 20 percent) are to be expected between the three techniques for measuring and predicting bend radius and movement. These results are encouraging considering the widely varying backgrounds and experience of the Beta testers. The results do, however, show that the manual techniques (simple overlay and computer assisted) tend to predict slightly smaller bend radii and rates of movement. Figure 58 shows measurements and predictions of bend radius and migration for the two sites. The line of perfect agreement and the best-fit lines are shown for bend radius and migration distance. This plot shows that the simple overlay and computer assisted techniques produce measurements of 11 or 12 percent less than the ArcView. This is probably related to a difference in manually fitting a circle versus the least-squares technique used in the ArcView tool. In the least-squares algorithm, the user digitizes points along the bankline and the algorithm fits a circle to the data. In the manual techniques, there is probably a tendency to inscribe a circle within the bankline, which would tend to yield smaller radii. With either technique, it is important to be consistent. This is discussed in the Handbook with recommendations given to the user to measure an average bankline rather than to inscribe a bankline.

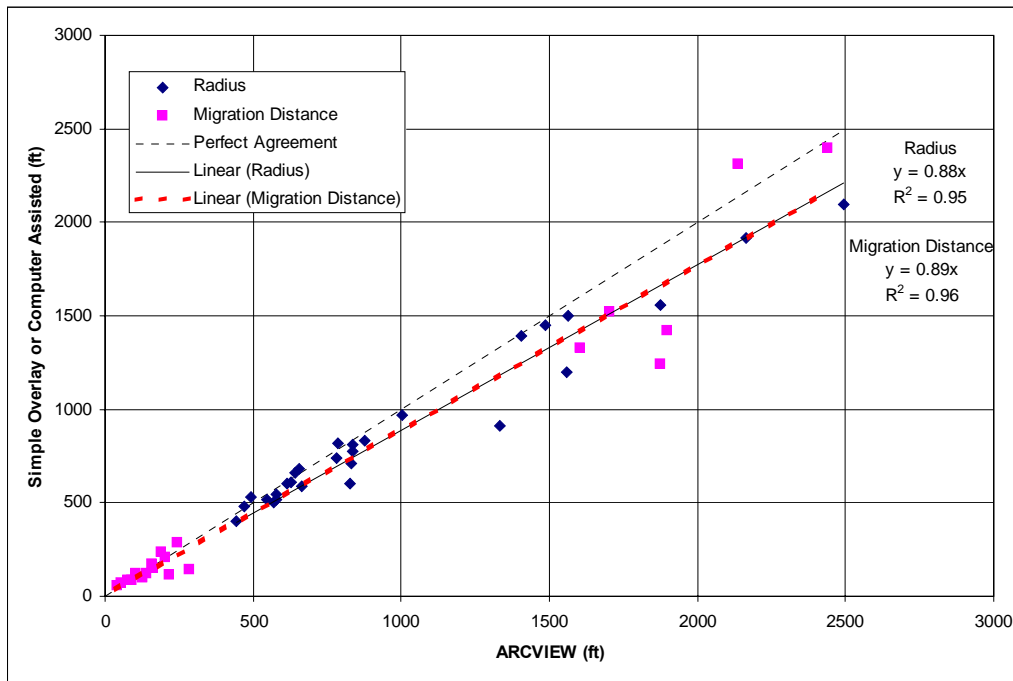

Figure 58. Comparison of ArcView and manual techniques for radius and migration.

Another use of the Beta test data is determining the consistency of bend measurements. For the two Beta test sites, the variability of the measurements was also reviewed. Tables C1 through C4 show all of the bend measurements for the in-house and state evaluations. For each bend, the average value and standard deviation were calculated for radius and migration distance. These results are summarized in Table C5. If all the measurements of radius and migration were identical, the standard deviation of the measurements would be zero. Since there is variability in the measurements, the magnitude of the standard deviations of the measurements is a measure of consistency.

As shown in the tables, the ArcView measurements produced slightly lower standard deviations than the manual techniques, so ArcView produces more consistent results. Also, measurements of bend radius had much lower standard deviations than migration distance, so measurements of radius are more consistent than migration distance. In summary, using ArcView, the average standard deviation for bend radius is 16 percent of the average measured value (68 percent of the measured values are within 16 percent of the mean) and the average standard deviation for migration distance is 34 percent of the average measured value. Using the simple overlay and computer assisted techniques, the average standard deviation for bend radius is 19 percent of the average measured value and the average standard deviation for migration distance is 36 percent of the average measured value.

The Beta test provided useful comments and suggestions on the Handbook and methodology. Between five and nine independent measurements of bend radius and migration distance were performed for each of the bends in the Beta test data set. These data showed reasonable consistency in the measurements and between the methods.

Summary of State DOT Comments

Table 8 provides contact information on the Beta test agencies. Two State DOTs (Alabama and California) provided comments on the Handbook, recommendations on the methodology, and returned their working documents (overlays) and digital files for evaluation. Maryland and Wyoming provided comments on the Handbook and methodology, and returned all files for evaluation except their ArcView files. Alaska provided comments and a detailed errata sheet for the Handbook, but did not return results or files from testing the methodology. The City of Austin, Texas provided general comments on the Handbook and methodologies. GaDOT was unable to complete the evaluation as the materials did not arrive in time for a summer intern to undertake the evaluation. General comments on the Handbook and methodologies are summarized below.

ALABAMA

Handbook

- Alabama has quite a few streams that meander across the State and this will be a very good and useful tool.
- The handbook was very well laid out and organized. It clearly stated the problem and reason for this project. The background chapters covered the different aspects of stream meandering and aerial photography where (anyone) could follow along.
- The procedure for the methodology was presented in a fashion that I like, step by step, and the explanations and illustrations were very good. I did have some problems especially in the introduction chapter, some sentences just didn't flow smoothly. If these sentences were broken up and pared down or just rewritten, the material would flow and read more smoothly.
- The work problems associated with the handbook were well prepared and thought out.

- PowerPoint and ArcView (were) a little frustrating at times.

Manual Overlay Technique

- The handbook outlined the manual overlay technique thoroughly using a step by step procedure.
- The biggest problem was getting the photos printed out.
- The steps outlining the manual overlay technique were easy to follow.

Computer Assisted Technique

- The process made it a lot easier once (you) figured out how to use the software tools.

ArcView Predictor

- The Data Logger and Channel Migration Predictor provided an even easier and faster way of predicting channel migration.
- I did not fully understand or comprehend how to import georeference photos into ArcView or other historical photos.
- There was also confusion on my part as to where the best location was to take certain measurements (upstream and downstream).

ALASKA

Handbook

- The manual is in very good shape. It will be useful for the practitioner.
- Most of my comments can be classified in the clarification or nitpicking categories.

CALIFORNIA

Handbook

- Thanks for letting me be a part of the Beta test for this project. I found it to be insightful and had some promise.
- I would like to get the final copy of the Handbook and programs when they are finalized.

Chapters 1 - 4 were clear, informative and straightforward.

Chapter 5 – The data that needs to be measured with the data logger is presented without much rationale for why or how the data is used.

Chapter 6 – The description of how to fit a circle to an odd shaped bend could be amplified more.

Chapter 7 - The methodology seemed straightforward when I read it through, but questions/problems arose when I tried the test cases.

Manual Overlay Technique

- Printing out the aerals on large 30 x 40 paper was a pain.
- I was not able to get the common registration points to overlay exactly making me wonder about the accuracy of my observations and work.
- Calculations of the predicted Radius of Curvature and Migration Angle left me confused. Issues regarding the use of judgment and reasonableness should be clarified further.
- More guidance should be given for when to use Eqn. 7.4 rather than using the Period B angle for Period C.
- Not discussed is Channel Width. After drawing the prediction circles, I was unclear on how to connect the new banklines together and just eyeballed a channel width to draw in the inner bank. This could be clarified.
- I was confused about how to deal with man-made structures.

Computer Assisted Technique

- Using the electronic files was easier than the manual method due to the size of the mapping used in the manual method.
- I was comfortable working with PowerPoint and the Drawing tools, but I think the Handbook should provide more basic instructions for others who may not be as familiar with these tools.
- The Handbook should have explained about how to get the size of the circles in PowerPoint. Also, instructions for how to create a new size of circle using the shape attributes and how to place the predicted circles at set distances and angles from the prior circle should be in the book.

ArcView Predictor

- Overall, I felt most confident using this method, because at least some of the subjectivity was removed by having the circles automatically fit the bend points.

- Measuring the wavelength and Amplitude was confusing. The start and end points for the wavelength and amplitude should be clearly defined.
- Where is the Apex of the Bend? At the center or the widest point? This should be clearly defined and illustrated.
- The Frequency Characteristics Section was a little confusing.

MARYLAND

Handbook

- We would like to compliment you for undertaking this effort that we see as an important step in creating design procedures based on stream morphology.
- We will not be able to test the procedures at one of our sites as all of them fall into the category of "confined" sites. We believe that such sites cannot be analyzed using the current procedures.
- The methodology developed in this handbook is the first of this kind to quantitatively predict stream bend migration.
- The text is well organized and concise. The contents are explained well and should be easily understood by practicing engineers.
- It is a very simple and workable method. However, the applications may be limited to stream bends of an unconfined nature with isotropic soil conditions. Where natural hard points or man-made structures confine the stream flows, the extrapolation of the historic records of bend migration into the future may not prove to be reliable.
- With regard to use of equations for prediction, a non-linear equation like Eq. 7.3 may serve better than a linear equation like Eq. 7.4 because non-linear extrapolation is based on three data points instead of two data points for linear extrapolation.

Computer Assisted Technique

- The (PowerPoint) process requires a change in scale in three different steps during the process. These changes are likely to create a scale factor problem in the developed prediction model. For this reason, we suggest using the CADD method instead of the PowerPoint method.
- Using CADD will serve to reduce the steps in this procedure and also provide better answers for the prediction. The user can import a digital map into CADD with a given scale, trace the stream alignments and perform various calculations for parameters such as the center of the circle and the radius of curvature. From this CADD file the user can then import the traced stream alignments into the bend prediction program, perform the analysis, and determine the

resulting prediction of the future bend location. During this procedure, only two steps are involved and no change of scale takes place.

NEVADA

Handbook

- I read the Handbook for clarity and found that it was easy to read and understand. I thought that tabs would be helpful for going back through the Handbook to do the exercises.
- There is only one area I would expand on and that was Frequency Characteristics of Bend Migration. This section was a little confusing to me.

Manual Overlay Technique

- The "Manual Overlay Technique" was very easy. The only thing I would add is to reiterate the importance of having the photos/map at a common scale to one another.
- I would like to reiterate that the Manual Overlay technique was so easy I don't see the need for the other options.

Computer Assisted Technique

- When I used the computer assisted overlay technique, I found this method to be time consuming and tedious. I would never use this method unless I was going to use it for a presentation or have some nice pictures for documentation purposes.

ArcView Technique

- While using the ArcView technique, I experienced several error messages bringing the data into ArcView. I've never used ArcView until now and I felt that the Handbook should give step-by-step instructions using ArcView. Because of time and my inexperience using ArcView, I didn't proceed any further.

TEXAS (City of Austin)

Handbook

- In general Chapters 7 and 8 contained examples that were easy to follow, once the map justification was complete. After completing one exercise, the procedure was easy to replicate.

Manual Overlay Technique

- It would be helpful to have more detailed instructions on justifying the three maps. It took a good deal of trial and error to produce maps that were of comparable scale.

Computer Assisted Technique

- It would be helpful to include more complete instructions on using PowerPoint for those not completely proficient.

ArcView Technique

- It would be helpful in using the data logger to have more precise instructions on the sequence of measuring and archiving.
- It would be helpful to have more detailed directions for delineation of banklines, image use and georeferencing in ArcView.
- It would be helpful to have more detailed directions on what to look for after themes are added on channel migration predictor module.
- Overall, I think the data logger and channel migration predictor hold great promise for using aerial photos to predict channel migration.

WYOMING

Handbook

- I found the paper (Handbook) to provide an excellent description of the meandering process and excellent background regarding past meander studies by other researchers. This lays a good foundation on which to study meandering patterns and erosion. The methods appear to be practical enough to employ on many highway projects.
- The Handbook presented a clear and organized background on stream morphology and meandering. The explanation for applying this methodology is also well written.
- These methods for predicting channel migration would be beneficial to our department. Each method proves useful based on project objective and resource constraints. Thanks.

Manual Overlay Technique

- The explanations for applying the methodology for the manual overlay technique were very clear. Explanations were sufficient enough that review of examples wasn't necessary. The examples were clear and provided guidance into the application of equations, and calculation of variable.

- The one exception was that there was some confusion when using the rate of change of migration angle equation.

Computer Assisted Technique

- MicroStation (CADD) was implemented for the computer assisted methodology.

ArcView Technique

- The Channel Migration Predictor was very well explained and worked with few problems

Summary and Planned Response to State Evaluation

Appendix C provides a summary of results from both internal testing (Task 6) and state evaluation (Task 8). While a range of results is apparent, this is not unexpected with an empirical approach requiring subjective judgments. The results are influenced by the background and experience of the evaluator and the care with which the measurements are done. They are also a function of the experience of the evaluator with manipulating map or aerial photography scales, determining registration points, and recognizing geomorphic features on aerial photography. As with any new skill, making reliable meander migration predictions from aerial photography requires practice and the skill can be improved with training (see Applications and Implementation).

In general, it can be concluded that the Beta test results indicate:

- The Handbook is well organized, well written, and generally easy to follow. The step-by-step approach on examples was well received.
- The Handbook provides useful methodologies that are easy enough to apply in practice to be used by DOTs on a regular basis to support design, rehabilitation, and maintenance decisions.
- The complexity of the computer assisted technique did cause problems for those not proficient in PowerPoint. Similarly, reviewers not familiar with GIS/ArcView had difficulty with that approach.
- All reviewers seemed to be comfortable with the basic manual overlay technique, which provides a good fall-back approach for any analysis. In fact, this fundamental approach may be the preferred methodology for a DOT with only a few sites to analyze or where meander predictions are required only infrequently for specific projects.

As a result of the Task 8 Beta test, the following modifications/revisions were made to the Handbook:

- Minor editorial changes and revisions.
- Review the Introduction for readability and make appropriate changes.

- Rewrite section on Frequency Analysis and provide more explanation.
- Clarify where and how to make critical measurements (e.g., amplitude, bend apex, channel width, wave length).
- Clarify the data requirements for the ArcView data logger.
- Provide cross references to Appendix B of the Handbook in all discussions describing how to fit a circle to a bend.
- Provide cross references to the expanded frequency analysis section where issues of judgment and reasonableness of a prediction are discussed.
- Amplify the discussion of the prediction of migration angle.
- Provide a section in Chapter 7 of the Handbook that references the possible use of CADD for analysis (see Maryland SHA comments on Computer Assisted Technique).

Several reviewers suggested that the Handbook should have more basic instruction in PowerPoint (California) and ArcView (Nevada). It is not the purpose of the Handbook to provide an introduction to or instruction in specific software packages such as PowerPoint or ArcView. There are numerous manuals, texts, and help files for this purpose. There are also other drawing tools that could be used for the computer assisted technique (e.g., Corel Draw) and CADD packages that will accomplish many of the same functions (e.g., MicroStation Descarte, AutoCAD). The Handbook assumes a certain level of familiarity and skill on the part of the user or access to staff (e.g., a GIS section) who can assist. The manual overlay technique provides a good fall-back approach for those not familiar with the more advanced approaches (see Nevada DOT comment).

APPLICATIONS AND IMPLEMENTATION

The Handbook

Approximately 84 percent of the 575,000 bridges in the National Bridge Inventory (NBI) are built over streams. A large proportion of these bridges span alluvial streams that are continually adjusting their beds and banks. Many, especially those on more active streams, will experience problems with scour, bank erosion, and channel migration during their useful life (201). The magnitude of these problems is demonstrated by the estimated average annual flood damage repair costs of approximately \$50 million for bridges on the Federal aid system.

Highway bridge failures caused by scour and stream instability account for most of the bridge failures in this country. A 1973 study for the Federal Highway Administration (226) indicated that about \$75 million were expended annually up to 1973 to repair roads and bridges that were damaged by floods. Extrapolating the cost to 2003 makes this annual expenditure to roads and bridges on the order of \$300 to \$500 million. This cost does not include the additional indirect costs to highway users for fuel and operating costs resulting from temporary closure and detours and to the public for costs associated with higher tariffs, freight rates, additional labor costs and time. The indirect costs associated with a bridge failure have been estimated to exceed the direct cost of bridge repair by a factor of five (227).

Rhodes and Trent (227) document that \$1.2 billion was expended for the restoration of flood damaged highway facilities during the 1980s. The damages, costs, and lost time resulting from bridge scour and stream instability during the 1992-1993 floods in the upper Mississippi River basin were extremely large. From available information on 23 bridge failures during the 1993 upper Mississippi River floods, 16 bridge failures were attributable to lateral channel migration or abutment failure, in which lateral migration may have been a contributing factor. An earlier study of 373 bridge failures in 1973 (226) indicated that 72 percent of the failures involved abutment damage. A more extensive study in 1978 (213) showed about 50 percent of the failures were from abutment problems, in which lateral channel migration may have been a contributing factor.

Although it is difficult to be precise regarding the actual cost to repair damage to the nation's highway system from problems related to channel migration, the number is obviously very large. In addition, the costs cited above do not include the extra costs that result from over design of bridge foundations (deeper foundation depths, unnecessary or over designed countermeasures) that result from our inability to predict of stream instability and channel migration. This lack of knowledge often results in overly conservative design.

A practical methodology to predict the rate and extent of channel migration could help reduce the cost of design, repair, rehabilitation and countermeasures for lateral channel instability. A screening procedure to identify stable meandering stream reaches would ensure that engineering and inspection resources are not allocated to locations where there is little probability of a problem developing.

The limitations of the comparison technique for predicting channel migration are related primarily to the quality and availability of the aerial photography. There are no inherent limitations with the GIS measurement and extrapolation tool developed for this project. Training time will be required for technicians or engineers to become familiar with the tool, and the DOT will need the hardware and software (in this case ArcView) to implement the procedure. Indications are that most DOTs currently have access to or will soon acquire the necessary GIS capability.

The Archive Data Base

The archive data base on CD ROM includes all meander site data acquired for this study. With the archive data set produced by this project, future researchers will have a readily accessible data base in a very useable format for a variety of studies. These studies could include additional empirical analyses and more complex regressions based on the archive data. The Brice data alone, which is part of the archive data set, is an invaluable resource for future researchers, particularly as it includes the field measurements compiled by the U.S. Army Corps of Engineers Waterways Experiment Station for their study of stable channel design. Additional data could be added to supplement or complement the data base. As deterministic modeling code improves over the next decade, this archived data will facilitate calibration and verification of physical-process models of river meandering, providing additional tools for the highway hydraulic engineer beyond the empirical techniques of this research.

Implementation

The Audience

The target audience for the results of this research are hydraulic engineers and maintenance and inspection personnel in state, federal, and local agencies with a river-related responsibility. These would include in rough order of priority:

- State Highway Agencies
- Federal Highway Administration
- City/County Bridge Engineers
- State Departments of Natural Resources
- U.S. Army Corps of Engineers
- U.S. Bureau of Reclamation
- Federal Emergency Management Agency
- Natural Resource Conservation Service (SCS)
- Consultants to the agencies, above
- Academic researchers in river engineering and geomorphology

Impediments to Implementation

A serious impediment to successful implementation of results of this research will be difficulties involved in reaching a diverse audience scattered among numerous agencies and institutions; however, this can be countered by a well-planned technology transfer program.

Because of the complexity of the meander migration process, the major challenge was to "package" the results in a form and format that can be used by a diverse audience with varying levels of technical sophistication. The Handbook, as a stand-alone document, provides a qualitative screening procedure and a range of photo comparison quantitative techniques from the relatively simple manual overlay approach to more sophisticated GIS-based measurement and prediction tools. With the guidance and examples contained in the Handbook, there should be something in these research results that will be of interest and assistance to almost every level of the primary target audience including: bridge inspectors, highway engineers, and practitioners in river engineering and geomorphology.

Leadership in Application

Because of its broad-based mission to provide guidance to the state highway agencies, the Federal Highway Administration must take a leading role in disseminating the results of this research. Through the National Highway Institute and its training courses, FHWA has the program in place to reach a diverse and decentralized target audience.

The Transportation Research Board through its annual meetings and committee activities, and publications such as the Transportation Research Record, as well as periodic bridge conferences can also play a leading role in disseminating the results of this research to the target

audience. The numerous committees of the American Association of State Highway and Transportation Officials (AASHTO) can also assist in this regard.

Finally, professional societies such as the American Society of Civil Engineers (ASCE) host conferences and publish peer reviewed journals through which the latest advances in engineering research and applications reach a wide audience, including many state, federal, and local hydraulic engineers. In this regard, the preliminary results of this research have already been presented by Research Team members at two ASCE conferences and the First International Conference on Scour of Foundations. An abstract has been submitted to the Sixteenth Hydrotechnical Conference, sponsored by the Canadian Society of Civil Engineering (CSCE) scheduled for the Fall of 2003.

Activities for Implementation

The activities necessary for successful implementation of the results of this research relate primarily to technology transfer activities as discussed above. FHWA/NHI have implemented the following:

- The latest edition of Hydraulic Engineering Circular (HEC) 20, "Stream Stability at Highway Structures" (201) introduces the basic concepts of meander migration prediction using comparative aerial photography.
- NHI Course #135046, "Stream Stability and Scour at Highway Bridges" includes a 90-minute demonstration workshop (Lesson 19) on the manual overlay meander prediction technique from the Handbook. Given that the next revisions to this training course may be three to five years in the future, FHWA requested and TRB approved adding a workshop on the Handbook methodology during the 2002 update of this course.

FHWA/NHI should implement the following:

- Include the results of this research in the next edition of HEC-20, "Stream Stability at Highway Structures."
- Include the results of this research in the next edition (or supplement the current edition) of Hydraulic Design Series (HDS) 6, "River Engineering for Highway Encroachments" (224).
- Add an instructional module on the Handbook procedures during the next revision of NHI course #135046, "Stream Stability and Scour at Highway Bridges."
- Add a lesson on the Handbook procedures during the next revision of NHI course #135010, "River Engineering for Highway Encroachments."

Criteria for Success

The best criteria for judging the success of this implementation plan will be acceptance of the methodology and techniques that resulted from this research by state highway agency engineers and others with responsibility for design, maintenance, rehabilitation, or inspection of highway facilities. Progress can be gaged by peer reviews of technical presentations and publications and by the reaction of state DOT personnel during presentation of results at NHI courses. A supplemental critique sheet could be used during NHI courses to provide feedback on the utility of the methodology and suggestions for improvement.

The desirable consequences of this project, when implemented, will be more efficient design, maintenance, and inspection of highway facilities considering channel migration impacts, and more effective use of countermeasures against lateral channel instability. The ultimate result will be a reduction in the number of bridge failures and reduction in damage to highway facilities attributable to channel migration.

CONCLUSIONS AND SUGGESTED RESEARCH

CONCLUSIONS

The Problem

Approximately 84 percent of the 575,000 bridges in the National Bridge Inventory (NBI) are built over streams. A large proportion of these bridges span alluvial streams that are continually adjusting their beds and banks. Many, especially those on more active streams, will experience problems with scour, bank erosion, and channel migration during their useful life. The magnitude of these problems is demonstrated by the estimated average annual flood damage repair costs of approximately \$50 million for bridges on the Federal aid system.

Highway bridge failures caused by scour and stream instability account for most of the bridge failures in this country. About \$75 million were expended annually up to 1973 to repair roads and bridges that were damaged by floods (226). Extrapolating the cost to 2003 makes this annual expenditure to roads and bridges on the order of \$300 to \$500 million. This cost does not include the additional indirect costs to highway users for fuel and operating costs resulting from temporary closure and detours and to the public for costs associated with higher tariffs, freight rates, additional labor costs and time. The indirect costs associated with a bridge failure have been estimated to exceed the direct cost of bridge repair by a factor of five (227). A study of 373 bridge failures in 1973 indicated that 72 percent of the failures involved abutment damage. A more extensive study in 1978 showed about 50 percent of the failures were from abutment problems, in which lateral channel migration may have been a contributing factor.

Although it is difficult to be precise regarding the actual cost to repair damage to the nation's highway system from problems related to channel migration, the number is obviously very large. In addition, the costs cited above do not include the extra costs that result from over design of bridge foundations (deeper foundation depths, unnecessary or over designed countermeasures) that result from our inability to predict of stream instability and channel migration. This lack of knowledge often results in overly conservative design.

A practical methodology to predict the rate and extent of channel migration could help reduce the cost of design, construction, repair, rehabilitation and countermeasures for lateral channel instability. A screening procedure to identify stable meandering stream reaches would ensure that engineering and inspection resources are not allocated to locations where there is little probability of a problem developing.

The basic objective of this research was to develop a practical methodology to predict the rate and extent of channel migration (i.e., lateral channel shift and down valley migration) in proximity to transportation facilities. The methodology developed will enable practicing engineers to evaluate and determine bridge and other highway facility locations and sizes and ascertain the need for countermeasures considering the potential impacts of channel meander migration over the life of a bridge or highway river crossing.

The Methodology

Literature Review

The propensity for flowing fluids to meander indicates that this behavior is inherent to shear flows and cannot be attributed solely to local non-uniformity of sediment transport or bank erosion, although both are necessary for meandering in alluvial rivers. While there is still much to be explained about the fundamental causes and mechanisms of meandering, it is clear from the literature that meandering is a natural attribute of most alluvial streams. It follows that meandering behavior should be expected in alluvial streams and must be accounted for in the design, siting, and inspection of highway bridge crossings on alluvial streams.

The review of the literature on meander growth and migration indicates that while the occurrence, patterns, and sequences of meander growth and migration have been well-documented, it is very difficult to predict the magnitude, direction, and rate at which changes will occur. It is clear that prior screening of bends to exclude those that are part of a multi-channel system, although they display meander-like behavior, is essential to successful predictions. Also, classification of the type of sinuosity present in single-thread, meandering streams greatly enhances predictive confidence. At the very least, the recognition that bends of equal channel width are relatively stable in contrast to meanders with variable width, should be of significance to the highway engineer. This simple observational criterion could eliminate many rivers from concern.

Many attempts have been made to model flow and sediment processes at bends, and the fundamental approaches that can be adopted have been fully reviewed in the literature summary of Chapter 2. A number of authors have attempted to produce simple models suitable for engineering applications by modifying more complex models. An example is the work of Garcia et al. (46) who developed the model of Ikeda et al. (47) specifically to provide a tool for stream management and engineering. The basic approach was to use spatial distribution of depth-averaged velocity to drive a morphological model capable of predicting bed scour and the spatial distribution of bank retreat. However, the practical utility of Garcia et al.'s model comes at the price of accepting limiting assumptions that rule out its application to many alluvial rivers. Johns Hopkins University (48) used historical records of bend movement for 26 study sites selected from the Brice collection to test the utility of Garcia et al.'s analytical model of bend migration. Their findings were not encouraging and they recommended against attempting to apply analytical models to make routine prediction of meander movement.

In spite of evidence that the prediction of meander shift using numerical models is possible in principle, many difficulties remain unresolved with this approach. Most models require field calibration that demands unrealistic lead times before predictions can be obtained. Also, the input data required is simply unavailable for most streams. Few models consider all of the processes known to be involved in meander migration and those that do are impractical for routine use due to their complexity and need for very accurate field data. In any case, sedimentary and geologic controls within the floodplain that cannot be detected in advance may interrupt progressive meander migration and cause deformation of the bend. In addition, changes of the meander pattern itself can complicate the bend behavior and, finally, human activities can have significant impacts. As a result, a river may be composed of reaches of very

different morphology, which requires that each meander must be described quantitatively, and predictions made for a single meander may not be transferred directly to another meander.

The conclusion to be drawn from the literature review is that the only complete model of a river is the river itself. While the past behavior of a meandering reach is not necessarily indicative of its future behavior, at least the historical record integrates the effects of all the relevant variables as they operate in that location. If changes in flow regime, sediment availability, bank materials or human activities are known to have occurred during the period of record, the response of the river in the past can indicate how the river may respond to continued changes in the future. It appears that, provided the planform evolution of the study reach can be accurately chronicled using aerial photographs and GIS techniques, a reliable basis exists for prediction by extrapolation on the basis of meander class and style of change, adjusted where appropriate, to account for changes known to have occurred during the period of record or believed to be likely to occur during the period of prediction.

Analysis Options

The conclusions from the literature review are supported by an evaluation of empirical and deterministic approaches to predicting meander migration. The study by Johns Hopkins University (48) was designed specifically to investigate the use of empirical and analytical approaches to provide solutions to the problem of predicting meander migration. The two approaches to prediction evaluated were: (1) the use of empirical (statistical) relationships between planform characteristics and controlling variables such as discharge, sediment loads, stream or valley gradient, and (2) the use of flow-based computational meander migration models. The Johns Hopkins study concluded that the multidimensional variability of the meander process cannot be captured in a simple regression equation. While several useful empirical relationships were developed for 26 study sites, local erosion direction was accurately predicted, on average, for only 62 percent of a given meandering reach.

Using the much larger enhanced data base assembled for this project leads to the same conclusion even when multi-variate regression analysis techniques are tried. Three modes of meander movement were considered: expansion of the radius of curvature, extension across valley, and translation down valley. For bend tightness (bend radius of curvature divided by channel width) and time, the best fit equation for the data yields an $R^2 = 0.23$, indicating that while there was a trend, there was significant scatter around the equation. Attempts to improve the predicted radius of curvature by including discharge, unit discharge, slope, stream power, unit-stream power, grain size, and percent silt-clay did not yield increased R^2 . Statistically significant relationships were also not forthcoming for the two other modes of meander migration, translation and extension.

As noted above, after testing a bend flow model for 26 of the meandering sites in the Brice data set, the Johns Hopkins study concluded that both the accuracy and applicability of the bend-flow meander migration model are limited by a number of simplifying assumptions. Among the most important of these are the use of a single discharge and the assumption of constant channel width, both of which prevent the model from successfully forecasting the spatial and temporal variability that appears to be inherent in the process of bend migration.

It was also concluded that much of the discrepancy between the predicted and observed distributions of erosion can be accounted for by the fact that meander migration is modeled as a smooth, continuous process. In reality, erosion occurs predominantly in discrete events, and varies greatly both temporally and spatially along the channel from bend to bend. The Johns Hopkins study noted that the identification of local factors that influence the amount of bank erosion that occurs is a subject that will require further investigation and that further refinements in bend-flow modeling will not improve our predictive capability until we find a more rational way to wed the flow model to a bank erosion model.

In 1999, the Federal Emergency Management Agency (FEMA) published a report which evaluated the feasibility of mapping Riverine Erosion Hazard Areas (REHA) and assessed the economic impact of erosion and erosion mapping on the National Flood Insurance Program (NFIP). The conclusions from this study were that despite decades of research into the physical processes associated with riverine erosion (which includes channel migration), knowledge of the subject is still imperfect, and much work remains to be done. Accurate mathematical representation of these processes has not been achieved yet, and available tools produce results surrounded by varying degrees of uncertainty. Nevertheless, there are analytical procedures that can be used to characterize riverine erosion and that, depending on the application, can yield reliable results. For example, because of limitations in data availability and model capabilities, it is extremely difficult to reproduce detailed time variation of stream movement; however, the FEMA study concluded, it is entirely feasible to analyze channel history and infer trends in the stream alignment and average migration rates.

Review of the literature, evaluation of analysis options, and consideration of data needs for empirical and deterministic (physical process mathematical modeling) approaches to predicting meander migration support the conclusion that, at present, empirical approaches are more likely than deterministic approaches to yield a practical methodology that will be useful to practicing engineers. Thus, the research approach for this project emphasized enhancing and using empirical data bases to develop photogrammetric comparison techniques as a basis for predicting meander migration.

The Handbook

A Handbook for using aerial photographs and maps to predict meander migration accompanies this Final Report. The Handbook contains applications guidance and examples for the analytical products of this research, map/aerial photograph comparison techniques and guidelines to predict channel migration in proximity to transportation facilities. This methodology will be useful in reconnaissance, design, rehabilitation, maintenance and inspection of highway facilities, particularly since the Handbook provides the methodology in a stand-alone package to facilitate ease of application. The end result will be a more efficient use of highway resources and a reduction in costs associated with the impacts of channel migration on highway facilities.

An essential first step in applying the methodology is screening and classifying the river reach(s) under consideration. Brice (49) attempted to discriminate qualitatively between very stable and less stable channels. He discovered that channels that do not vary significantly in width were relatively stable, whereas channels that were wider at bends were more active. High

sinuosity equal-width streams were the most stable, whereas other equal-width streams of lower sinuosity were less stable, and wide bend streams had the highest erosion rates. As presented in the Handbook, this simple stratification of meanders will be of value to the bridge engineer as a screening procedure, allowing preliminary identification of meanders that are very stable. Brice's conclusions were validated by regression analyses using the expanded data base assembled for this project.

Of the approaches reviewed, the classification system of Figure 11 (Chapter 2) was adopted as the most applicable for the purposes of this project. As shown in Figure 11, nine screening and classification categories can be used to represent the full range of meandering rivers encountered in the field. As noted above, equiwidth rivers, such as A, B₁, and G₁, can be screened as stable, but one class, the "wandering" river, should be screened as potentially so unstable and unpredictable that further evaluation would not be likely to produce a meaningful result (in terms of predicting meander migration). All other meandering rivers can be classed as one of the remaining five categories, and analyzed by the photogrammetric comparison techniques presented in the Handbook.

As with any analytical technique, aerial photograph comparison technologies have limitations. The accuracy of photo comparison is greatly dependent on the period over which migration is evaluated, the magnitude of internal and external perturbations forced on the system over time, and the number and quality of sequential aerial photos and maps. The analysis will be much more accurate for a channel that has coverage consisting of multiple data sets (aerial photos, maps, and surveys) covering a long period of time (several decades to more than 100 years) versus an analysis consisting of only two or three data sets covering a short time period (several years to a decade). Predictions of migration for channels that have been extensively modified or have undergone major adjustments attributable to extensive land use changes will be much less reliable than those made for channels in relatively stable watersheds.

Overlay techniques require the availability of adequate maps and aerial photos that cover a sufficient period of time to be useful. It is the ready availability of aerial photography resources that make the methodologies presented in the Handbook powerful and practical tools for predicting meander migration. Historical aerial photos and maps can be readily obtained from a number of federal, state, and local agencies and the Handbook provides specific guidance for archive and Internet-based search. In general, both air photos and maps will be required to perform a comprehensive and relatively accurate meander migration assessment. Since the scale of aerial photography is often approximate, contemporary maps are usually needed to accurately determine the true scale of air photos without the use of sophisticated photogrammetric instruments.

In addition to scale adjustment and distortion problems that are inherent in the use of aerial photography for comparative purposes, there are a number of physical characteristics of the river environment that can complicate the prediction of meander migration impacts on transportation facilities. Countermeasures to halt bank erosion or protect a physical feature within the floodplain can have an impact on the usefulness of the overlays and these features should be identified prior to developing the overlays. Anomalous changes in the bend or bankline configuration or a major reduction in migration rates may suggest that bank protection

is present, especially in areas where the bankline is not completely visible or on images with poor resolution.

Geologic features, such as clay plugs or rock outcrops, in the floodplain can also limit the usefulness of the overlays because they can have a significant influence on migration patterns. Bends can become distorted as they impinge on these features and localized bankline erosion rates may decrease significantly as these erosion resistant features become exposed in the bank. In reaches where geologic controls are exposed predominantly in the bed of the channel, migration rates may dramatically increase because the channel bed is not adjustable, which may cause the channel to migrate rapidly across the feature. A fundamental assumption of the overlay techniques based on aerial photo or map comparison is that a time period sufficient to "average out" such anomalies will be available, making the historic meander rates a reasonable key to the future.

These limitations notwithstanding, the results of internal and external Beta testing of the methodologies presented in the Handbook support the conclusion that map and aerial photograph comparison techniques represent the most practical methodology currently available to enable State DOT engineers to predict and plan for the potential impacts of meander migration. Testing and evaluation of the manual overlay technique, computer assisted technique, and GIS-based approach in the Handbook by six State DOTs strongly support the following conclusions:

- The Handbook is well organized, well written, and generally easy to follow. The step-by-step approach on examples was well received.
- The Handbook provides useful methodologies that are easy enough to apply in practice to be used by DOTs on a regular basis to support design, rehabilitation, and maintenance decisions.
- All reviewers were comfortable with the basic manual overlay technique, which provides a good fall-back approach for any analysis. In fact, this fundamental approach may be the preferred methodology for a DOT with only a few sites to analyze or where meander predictions are required only infrequently for specific projects.

As an additional internal test of the methodology, the ArcView GIS-based meander migration predictor was applied to the evaluation of 43 active, freely meandering bends with three time periods of photography. The results indicate that: (1) bank erosion direction was predicted within 0 to 30 degrees in nearly 80 percent of the cases; (2) maximum bank migration magnitude was predicted within an accuracy of one percent of channel width per year over the time period covered by the prediction; and (3) this level of accuracy was comparable to the variability of channel width. A qualitative assessment of the procedure indicates that the majority of the predictions were reasonable and compared well with the actual channel migration.

The Archive Data Base

Another deliverable for this project is an archive of the data base compiled on CD-ROM to include all meander site data acquired for this study. The CD-ROM archives contain the Excel workbooks, MicroStation files, 1990s and historic (where applicable) aerial photos, and the topographic maps for each site in digital file format. The data base includes 141 meander sites containing 1,503 meander bends on 89 rivers in the U.S. The data for each meander site is compiled in Microsoft Excel workbooks. There are multiple spreadsheets within each of the workbooks. The first spreadsheet, designated General Data, contains the general information compiled from various sources and an aerial photo showing the site limits and the included meander bends. Each meander bend is numbered from upstream to downstream. There are individual spreadsheets, designated by the bend number, which contain detailed historic data for each of the bends of the site. There is also a spreadsheet, designated Discharge Data, that has the mean daily and annual peak discharge data for the gage nearest to the site. Finally, a summary spreadsheet contains all the measured data for all the bends of the site.

The Excel workbook file includes four spreadsheets that cross-reference each data site by the (1) source of the data, (2) stream classification, (3) river name, and (4) state in which the site is located. This Excel spreadsheet format permits cross-referencing and provides a simple and useable approach to searching the data base. With this archive data set, future researchers will have a readily accessible data base in a very useable format for a variety of studies. These studies could include additional empirical analyses, more complex regressions based on the archive data, and research to develop more practical deterministic models of the meandering process.

SUGGESTED RESEARCH

It is apparent from the literature review and evaluation of analysis options in Chapter 2, as well as from the conclusions presented in this chapter, that much work remains to be done before the potential impacts of meander migration on transportation infrastructure can be predicted with certainty and ease using statistical or deterministic methods. While the results of this research, comparative analysis based on maps and aerial photography, could be viewed as an interim approach, it is not likely that this approach will be replaced by more sophisticated analytical techniques in the near future. The techniques presented in the Handbook will always be useful at the reconnaissance level or as a "reality check" on other approaches to solving the problem of predicting meander migration.

At present, it appears that advances in analyzing and predicting meander migration will take one of the two traditional avenues evaluated in this study: empirical (primarily statistical/regression) and deterministic (numerical physical process modeling). As identified in the literature review and conclusions, progress on either avenue will require a substantial investment of research resources.

While the archive data base assembled for this project will provide a significant resource for an approach along statistical lines, neither the single variable approach with a limited data base attempted by Johns Hopkins University or the multi-variate approach with a greatly expanded data base yielded significant results. Conceivably, an expanded data base with broader

geographic distribution could permit segmenting the data by geographic or geomorphic region rather than by meander class, leading to regional regression equations for meander migration. However, this approach was considered carefully at the outset of this project, and rejected on the grounds of practicability and budget. It is by no means certain that the meandering process would exhibit regional, as opposed to river class, characteristics.

A deterministic (numerical modeling) approach clearly faces substantial obstacles. The FEMA study in 1999 concluded that despite decades of research into the physical processes associated with riverine erosion, our knowledge of the subject is still imperfect, much work remains to be done, and mathematical representation of these processes has not yet been achieved. The Johns Hopkins University study in 1996 noted that identification of local factors that influence bank erosion is a subject that will require further investigation. It was also concluded as a result of that study that further refinements in bend-flow modeling will not improve our predictive capability until we find a more rational way to "wed" the flow model to the bank erosion model. The data needs alone to develop and apply a purely deterministic or process-based model are formidable.

While advances will be made in deterministic modeling of geomorphic processes such as meander migration, at least from a research perspective, configuring the resulting model to provide a practical tool for application by DOTs will remain a challenge. Here again, the archive data base developed for this project could support progress by providing field data for model development, calibration, and testing.

Several improvements could be made to the GIS-based measurement and prediction techniques. While the Panel suggested combining the Data Logger and Channel Migration Predictor ArcView extensions, the budget did not permit this enhancement. The data acquisition and prediction steps of the comparative methodology would be streamlined if these tools were combined. In addition, the ArcView extensions are developed as avenue scripts in ArcView 3.2, but should be in ArcGIS 8.3 or greater to take advantage of advances in GIS technology and to ensure continued support by the GIS software developer. Finally, the prediction tool itself could be improved to handle the more complex case of change in the direction of bend migration where three time periods of photography are available for comparison. The predictor currently applies a straight line extrapolation of the direction of migration established by the two most recent time periods.

REFERENCES

1. Whitlow, J., 1984, "Dictionary of Physical Geography," Penguin, London, 591 p.
2. Zeller, J., 1967, "Meandering Channels in Switzerland," Symposium on river morphology, International Association Science Hydrology Publication 75, p. 174-186.
3. Davies, T.R.H., and Tinker, C.C., 1984, "Fundamental Characteristics of Stream Meanders," *Geological Society of America Bulletin*, Vol. 95, No. 5, pp. 505-512.
4. Thorne, C.R., 1992, "Bend Scour and Bank Erosion on the Meandering Red River, Louisiana," In: P.A. Carling and G.E. Petts (eds.), *Lowland Floodplain Rivers: Geomorphological Perspectives*, John Wiley and Sons, Chichester, UK, 95-115.
5. Davis, D.H., 1908, "A Study of River Meanders on the Middle Rouge (Michigan)," *Journal of Geology*, p. 755-764.
6. Ashworth P., Bennett, S., Best, J., and McLelland, S., 1996, "Coherent Flow Structures in Open Channels," John Wiley and Sons, Chichester, UK.
7. Bathurst, J.C., Thorne, C.R., and Hey, R.D., 1979, "Secondary Flow and Shear Stress at River Bends," *Journal of the Hydraulics Division*, ASCE, Vol. 10, Proc. Paper 14906, pp. 1277-1295, and discussion Vol. 106, No. HY10, pp. 1710-1713 and Closure, Vol. 107, HY5, 644-647.
8. Smith, S.A., 1987, "Gravel Counterpoint Bars: Examples from the River Tywi, South Wales," *SEPM, Spec. Publ. No. 39*, F.G. Ethridge, R.M. Flores, and M.D. Harvey (eds.), p. 75-81.
9. Einstein, H.A. and Shen, H.W., 1964, "A Study of Meandering in Straight Alluvial Channels," *Journal of Geophysical Research*, 69, pp. 5329-5347.
10. Rhoads, B.L. and Welford, M.R., 1991, "Initiation of River Meandering," *Progress in Physical Geography*, Vol. 15, No. 2, p. 127-156.
11. Friedkin, J.F., 1945, "A Laboratory Study of the Meandering of Alluvial Rivers," U.S. Army Engineers Waterways Experiment Station, Vicksburg, MS.
12. Keller, E.A., 1972, "Development of Alluvial Stream Channels: A Five-Stage Model," *Geological Society of America Bulletin*, Vol. 83, p. 1531-1540.
13. Hakanson, L., 1973, "The Meandering of Alluvial Rivers," *Nordic Hydrology*, Vol. 4, No. 2, p. 119-128.

14. Leopold, L.B. and Wolman, M.G., 1957, "River Channel Patterns: Braided, Meandering and Straight," U.S. Geological Survey Professional Paper 282B, 85 p.
15. Thomson, J.J., 1876, "On the Windings of Rivers in Alluvial Plains," *Proceedings of the Royal Society of London*, 25, 5-8.
16. Furbish, D.J., 1988, River-bend Curvature and Migration: How are They Related?," *Geology*, Vol. 16, p. 752-755.
17. Leopold, L.B., Wolman, M.G., and Miller, J.P., 1964, "Fluvial Processes in Geomorphology," Freeman Press, San Francisco, 522 p.
18. Henderson, F.M., 1966, "Open Channel Flow," New York, MacMillan, 522 p.
19. Bathurst, J.C., Thorne, C.R., and Hey, R.D., 1977, "Direct Measurements of Secondary Currents In River Bends," *Nature*, Vol. 269, No. 5628, 504-506
20. Lapointe, M.F. and Carson, M.A., 1986, "Migration Patterns of an Asymmetric Meandering River: The Rouge River, Quebec," *Water Resources Research*, Vol. 22, No. 5, pp. 731-743.
21. Thorne, C.R. and Lewin, J., 1979. "Bank Processes, Bed Material Movement and Planform Development in a Meandering River," In: D.D. Rhodes and G.P. Williams, (eds.), *Adjustments of the Fluvial System*, Kendall/Hunt Publishing Co, Dubuque, IA, USA, 117-137.
22. Thorne, C.R., 1982, "Processes and Mechanisms of River Bank Erosion," In: Hey, R.D., Bathurst, J.C., and Thorne, C.R. (eds.), *Gravel-bed Rivers*, John Wiley and Sons, New York, p. 227-71.
23. Richards, K., 1982, "Rivers: Form and Process in Alluvial Channels," Methuen, London, 358 p.
24. Knighton, D., 1984, "Fluvial Forms and Processes," Edward Arnold, Baltimore, MD, 218 p.
25. Dietrich, W.E. and Smith, J.D., 1983, "Influence of the Point Bar on Flow Through Curved Channels," *Water Resources Research*, Vol. 19, p. 1173-1192.
26. Thorne, C.R., Zevenbergen, L.W., Pitlick, J.C., Rais, B., Bradley, J.B., and Julien, P.Y., 1985, "Direct Measurements of Secondary Currents in a Meandering Sand-bed River," *Nature*, Vol. 316, No. 6022, 746-747.
27. Smith, S.A. and McLean, 1984, "A Model for Meandering Rivers," *Water Resources Research*, Vol. 20, p. 1301-1315.

28. Markham, A.J. and Thorne, C.R., 1992, "Geomorphology of Gravel-bed River Bends," In: P. Billi, R.D. Hey, C.R. Thorne, and Tacconi, P. (eds.), *Dynamics of Gravel-bed Rivers*, John Wiley and Sons, Chichester, UK, 433-456.
29. Bagnold, R.A., 1960, "Some Aspects of the Shape of River Meanders," USGS Prof. Paper 181E, p. 135-144.
30. Chang, H.H., 1984, "Analysis of River Meanders," ASCE, *Journal of Hydraulic Engineering*, Vol. 110, No. 1, pp. 37-50.
31. Leeder, M.R. and Bridges, P.H., 1975, "Flow Separation in Meander Bends," *Nature*, Vol. 253, p. 338-339.
32. Hooke, J.M., 1997, "Styles of Channel Change," In: Thorne, C.R., Newson, M.D., and Hey, R.D. (eds.), *Applied Fluvial Geomorphology for River Engineering and Management*, John Wiley and Sons, Chichester, UK, 237-268.
33. Page, R.W. and Nanson, G.C., 1982, "Concave Bank Benches and Associated Floodplain Formation," *Earth Surface Processes and Landforms*, Vol. 7, p. 529-542.
34. Reid, J.B., 1984, "Artificially Induced Concave Bank Deposition as a Means of Floodplain Erosion Control," In: Elliott, C.M. (ed.), *River Meandering, Proceedings of the Conference Rivers '83*, New Orleans, LA, p. 295-305.
35. Hey, R.D., 1984, "Plan Geometry of River Meanders," In: Elliott, C.M. (ed.), *River Meandering, Proceedings of the Conferences Rivers '83*, New Orleans, LA, p. 30-43.
36. Hooke, J.M. and Redmond, C.E., 1992, "Causes and Nature of River Planform Changes," In: Billi, P., Hey, R.D., Thorne, C.R., and Tacconi, P. (eds.), *Dynamics of Gravel-bed Rivers*, John Wiley and Sons, Chichester, UK, p. 557-571.
37. Parker, G., Klingemena, P.C., and McClean, D.G., 1982, "Bedload and Size Distribution in Paved Gravel-bed Streams," *ASCE Journal of Hydraulics*, 108(HY4), p. 544-571.
38. Elliott, C.M. (ed.), 1984, "River Meandering," *Proceedings of the Conference Rivers '83*, New Orleans, LA, 1036p.
39. Ikeda, S. and Parker, G. (eds.), 1989, "River Meandering," AGU Water Resources Monograph 12, 485 p.
40. Engelund, F., 1974, "Flow and Bed Topography in Channel Bends," *Journal Hydraulics*, Vol. 100, p. 1631-1648.
41. Odgaard, A.J., 1989, "River-Meander Model I: Development," *Journal of Hydraulic Engineering*, ASCE, Vol. 115, No. 11, p. 1433-1450.

42. Odgaard, A.J., 1989, "River-Meander Model II: Applications," *Journal of Hydraulic Engineering*, ASCE, Vol. 115, No. 11, p. 1451-1464.
43. Odgaard, A.J. and Bergs, M.A., 1987, "Flow in Curved Erodible Channels," IAHR Congress 1987, p. 136-141.
44. Odgaard, A.J., 1987, "Streambank Erosion Along Two Rivers in Iowa," *Water Resources Research*, Vol. 23, No. 7, p. 1225-1236.
45. Dietrich, W.E., Smith, J.D., and Dunne, T., 1984, "Boundary Shear Stress, Sediment Transport and Bed Morphology in a Sand-Bedded River Meander During High and Low Flow," In: Elliott, C.M. (ed.) *River Meandering, Proceedings of the Conference Rivers '83*, New Orleans, LA, p. 632-639.
46. Garcia, M.H., Bittner, L., and Nino, Y., 1994, "Mathematical Modeling of Meandering Streams in Illinois: A Tool for Stream Management and Engineering," Dept. Civil Engineering, University of Illinois at Urbana-Champaign, Urbana, IL.
47. Ikeda, S., Parker, G., and Sawai, K., 1981, "Bend Theory of River Meanders, Part 1, Linear Development," *Journal Fluid Mechanics*, Vol. 112, p. 363-377.
48. Cherry, D.S., Wilcock, P.R., and Wolman, M.G., 1996, "Evaluation of Methods for Forecasting Planform Change and Bankline Migration in Flood-control Channels," Department of Geography and Environmental Engineering, Johns Hopkins University, prepared for U.S. Army Engineer Waterways Experiment Station, Vicksburg, MS.
49. Brice, J.C., 1982, "Stream Channel Stability Assessment," Federal Highway Administration Report RHWA/RD-82/021, 41 p.
50. Leopold, L.B. and Langbein, W.B., 1966, "River Meanders," *Scientific American*, Vol. 214, No. 6, p. 60-69.
51. Ferguson, R.I., 1973, "Regular Meander Path Models," *Water Resources Research*, Vol. 9, p. 1079-1086.
52. Carson, M.A. and Lapointe, M.F., 1983, "The Inherent Asymmetry of River Meander Planform," *Journal Geology*, Vol. 91, p. 41-55.
53. Ferguson, R.I., 1977, "Meander Sinuosity and Direction Variance," *Geological Society of America Bulletin*, Vol. 88, p. 212-214.
54. Lewin, J., 1978, "Meander Development and Floodplain Sedimentation: A case study from mid-Wales," *Geology Journal*, Vol. 13, Part 1, p. 25-36.

55. Chang, H.H., 1988, "Processes of Meander Bend Migration," Discussion of effect of flow paths on migration of symmetrical meanders, In: Abt, S.R. and Gessler, J. (eds.), *Proceedings 1988 ASCE Conference*, Hydraulic Engineering, p. 690-695.
56. Whitesell, B.L., Vitek, J.D., and Butler, D.R., 1988, "Changes in the Planform of the Red River," McCurtain County, Oklahoma, 1938-1984, *Oklahoma Geology Notes*, Vol. 48, No. 5, p. 196-211.
57. Weihaupt, J.G., 1989, "Disparities in the Forms of River Meanders and Oxbow Lakes," Water Resources Publications, Littleton, CO, 184 p.
58. Fisk, H.N., 1944, "Fine-grained Alluvial Deposits and their Effects on Mississippi River Activity," U.S. Army Eng. Waterways Expr. Sta., Vol. 2., Vicksburg, MS.
59. Furbish, D.J., 1991, "Spatial Autoregressive Structure in Meander Migration," *Geological Society of America Bulletin*, Vol. 103, p. 1576-1589.
60. Schumm, S.A. and Thorne, C.R., 1989, Geologic and Geomorphic Controls of Bank Erosion," In: Ports, M.A. (ed.), *Proceedings of the National Conference on Hydraulic Engineering*, New Orleans, LA, p. 106-111.
61. Schumm, S.A., Rutherford, I.D., and Brooks, J., 1994, Pre-cutoff Morphology of the Lower Mississippi River," In: Schumm, S.A., and Winkley, B.R. (eds.), *The Variability of Large Alluvial Rivers*, ASCE Press, New York, p. 13-44.
62. Dort, W., Jr., 1978, "Channel Migration Investigation, Historic Channel Change Maps, Kansas River and Tributaries Bank Stabilization Component, Kansas and Osage Rivers," Kansas Study, U.S. Army Corps of Engineers, Kansas City District.
63. Hooke, J.M. and Redmond, C.E., 1989, "Use of Cartographic Sources for Analyzing River Channel Change with Examples from Britain," In: Petts, G.E. (ed.), *Historical Change of Large Alluvial Rivers: Western Europe*, John Wiley and Sons, Chichester, UK, p. 79-93.
64. Leopold, L.B. and Wolman, M.G., 1960, "River Meanders," *Geological Society of America Bulletin*, Vol. 71, p. 769-794.
65. Hickin, E.J., 1977, "The Analysis of River-planform Responses to Changes in Discharge," In: Gregory, K.J. (ed.), *River Channel Changes*, John Wiley and Sons, Chichester, UK, p. 249-263.
66. Carlston, C.W., 1965, "The Relation of Free Meander Geometry to Stream Discharge and its Geomorphic Implications," *American Journal Science* 263, 864-85.
67. Chang, T.P. and Toebes, G.H., 1970, "A Statistical Comparison of Meander Planforms in the Wabash Basin," *Water Resources Research*, Vol. 6, No. 2, p. 557-578.

68. Chang, T.P. and Toebes, G.H., 1980, "Geometric Parameters for Alluvial Rivers Related to Regional Geology," *Proceedings International Association for Hydraulic Research Congress 14*, Vol. 3, p. 192-201.
69. Williams, G.P., 1986, "River Meanders and Channel Size," *Journal of Hydrology*, 88 (1-2), pp. 147-164.
70. Rinaldi, M. and Johnson, P.A., 1997, "Characterization of Stream Meanders for Stream Restoration," *Journal of Hydraulic Engineering*, ASCE, 123(6), 567-570.
71. Brice, J.C., 1974, "Evolution of Meander Loops," *Geological Society of America Bulletin*, Vol. 85, p. 581-586.
72. Brice, J.C., 1975, "Air Photo Interpretation of the Form and Behavior of Alluvial Rivers," final report to the U.S. Army Research Office, Washington, D.C.
73. Brice, J.C., 1984, "Planform Properties of Meandering Rivers," In: Elliott, C.M. (ed.), *River Meandering, Proceedings of the Conference Rivers '83*, New Orleans, LA, p. 1-15.
74. Schumm, S.A., Erskine, W.D., and Tilleard, J.W., 1996, "Morphology, Hydrology, and Evolution of the Anastomosing Ovens and King Rivers," Victoria, Australia, *Geological Society of America Bulletin*, Vol. 108, No. 10, p. 1212-1224.
75. Gottesfeld, A.S. and Johnson-Gottesfeld, L.M., 1990, "Floodplain Dynamics of a Wandering River, Dendrochronology of the Morice River," British Columbia, Canada, *Geomorphology*, Vol. 3, No. 2, p. 159-179.
76. Neill, C.R. and Collins, C.M., 1991, "Hydraulic/Geomorphic Relationships in a Braided to Meandering Transition, Study of Streams and Watersheds of High Hydraulic Irregularity," *Proceedings XXIV International Association for Hydraulic Research Congress*, Madrid, Spain, p. 137-147.
77. Jones, L.S. and Harper, J.T., 1998, "Channel Avulsions and Related Processes, and Large-scale Sedimentation Patterns since 1875, Rio Grande," San Luis Valley, Colorado, *Geological Society of America Bulletin*, Vol. 110, p. 411-421.
78. Carson, M.A., 1986, "Characteristics of High-energy Meandering Rivers," The Canterbury Plains, New Zealand, *Geological Society of America Bulletin*, Vol. 97, p. 886-895.
79. Alabyan, A.M. and Chalor, R.S., 1998, "Types of River Channel Patterns and Their Natural Controls," *Earth Surface Processes and Landforms*, Vol. 23, p. 467-474.
80. Brice, J., 1977, "Lateral Migration of the Middle Sacramento River, California," USGS Water Resources Investigation 77-43, 51 p.

81. Brice, J.D., 1983, "Factors in Stability of Relocated Channels," *Journal of Hydraulic Engineering*, ASCE, Vol. 109, No. 10, pp. 1298-1313.
82. Lewin, J. and Brindle, B.J., 1977, "Confined Meanders," In: Gregory, K.J. (ed.), *River Channel Changes*, John Wiley and Sons, Chichester, UK, p. 221-233.
83. Stølum, Hans-Henrik, 1998, "Planform Geometry and Dynamics of Meandering Rivers," *Geological Society of America Bulletin*, Vol. 110, No. 11, pp. 1485-1498.
84. Braga, G. and Gervasoni, S., 1989, "Evolution of the Po River: An example of the Application of Historic Maps," In: Petts, G.E., Möller, H., and Roux, A.L. (eds.), *Historical Change of Large Alluvial Rivers: Western Europe*, John Wiley and Sons, New York, p. 113-126.
85. Hussey, K.M. and Zimmerman, H.L., 1954, "Rate of Meander Development as Exhibited by Two Streams in Story County, Iowa," *Proceedings of the Iowa Academy of Science*, 60, p. 390-392.
86. Sundborg, A., 1956, "The River Klaralven, a Study of Fluvial Processes," *Geogr. Annaler.*, Vol. 38, p 127-316.
87. Carey, W.C., 1969, "Formation of Floodplain Lands," *Journal of Hydraulic Engineering*, ASCE, Vol. 95.
88. Hickin, E.J., 1974, "The Development of Meanders in Natural River-Channels," *American Journal of Science*, Vol. 274, p. 414-442.
89. Jurado, A. and Fields, F.K., 1978, "Channel Migration of the White River in the Eastern Uinta Basin," *Utah and Colorado, U.S. Geological Survey, Miscellaneous Invest. Series*, I-1087.
90. Nanson G.C. and Hickin, E.J., 1983, "Channel Migration and Incision on the Beaton River," *Journal of Hydraulic Engineering*, ASCE, Vol. 109.
91. Nanson G.C. and Hickin, E.J., 1986, "A Statistical Analysis of Bank Erosion and Channel Migration in Western Canada," *Geological Society of America Bulletin*, Vol. 97, pp. 497-504.
92. Decamps, H., Fortune, M., and Gazelle, F., 1989, "Historical Changes of the Garonne River, Southern France," In: Petts, G.E., Möller, H., and Roux, A.L. (eds.), *Historical Change of Large Alluvial Rivers: Western Europe*, John Wiley and Sons, New York, p. 249-267.
93. Harvey, M.D., 1989, "Meanderbelt Dynamics of the Sacramento River," *Proceedings, California Riparian Systems Conference*, USDA Forest Service General Technical Report PSW-110, 54-61.

94. Hooke, J.M., 1984, "Changes in River Meanders: A Review of Techniques and Results of Analyses," *Progress in Physical Geogr.*, Vol. 8, p. 473-508.
95. Hooke, J.M., 1991, "Non-linearity in River Meander Development: Chaos Theory and its Implications," Dept. of Geography, Univ. of Portsmouth, Working Paper 19, 13 p.
96. Hickin, E.J., 1978, "Hydraulic Factors Controlling Channel Migration," In: Davidson-Arnott, R. and Nickling, W. (eds.), *Research in Fluvial Geomorphology, Proceedings 5th Guelph Symposium on Geomorphology*, p. 59-66.
97. Hickin, E.J., 1983, "River Channel Changes: Retrospect and Prospect," In: Collinson, J.D. and Lewin, J. (eds.), *Modern and Ancient Fluvial Systems*, Basil Blackwell, Oxford, 61-83.
98. Hickin, E.J. and Nanson, G.C., 1975, "The Character of Channel Migration on the Beaton River, Northeast British Columbia, Canada," *Geological Society of America Bulletin*, Vol. 86, p. 487-494.
99. Nanson, G.C., 1980, "A Regional Trend to Meander Migration," *Journal Geology*, Vol. 88, p. 100-108.
100. Hickin, E.J. and Nanson, G.C., 1984, "Lateral Migration Rates of River Bends," *Journal of Hydraulic Engineering*, ASCE, Vol. 110, No. 11, pp. 1557-1567.
101. Lewis, G.W. and Lewin, J., 1983, "Alluvial Cutoffs in Wales and the Borderlands," IAS Spec. Publ. No. 6, J.D. Collinson and J. Lewin (eds.), p. 145-154.
102. Martinson, H.A. and Meade, R.H., 1983, "Channel Changes of Powder River 1938-1978, Powder River Country, Montana," U.S. Geol. Survey, Hydrologic Invest. Atlas, HA-0661.
103. Begin, Ze'ev B., 1986, "Curvature Ratio and Rate of River Bend Migration Update," *Journal of Hydraulic Engineering*, Vol. 112, No. 10, p. 904-908.
104. Biedenharn, D.S., Combs, P., Hill, G.J., Pinkard, C., and Fred, Jr., Pinkston, C.B., 1989, "Relationship Between Channel Migration and Radius of Curvature on the Red River," *Proceedings of the International Symposium on Sediment Transport Modeling*, p. 536-541.
105. Petts, G.E., Möller, H., and Roux, A.L. (eds.), 1989, "Historical Change of Large Alluvial Rivers, Western Europe," John Wiley and Sons, Chichester, UK, 355 p.
106. Thorne, C.R., 1991, "Bank Erosion and Meander Migration of the Red and Mississippi Rivers," USA, In: Van de Ven, F.H.m., Gutnecht, D., Loucks, D.P., and Satewicz, K.A. (eds.), *Hydrology for the Water Management of Large Rivers*, IAHS-AISH Pub. 201, p. 301-313.

107. Sidorchuk, A. and Matveev, B., 1997, "Channel Processes and Erosion Rates in the Rivers of the Yamal Peninsula in Western Siberia," In: Olive, L.J., Loughran, R.J., and Kesby, J.A. (eds.), *Variability in Stream Erosion and Sediment Transport*, IAHS-AISH Publication 224, p. 197-202.
108. Larsen, E. and Shen, H.W., 1989, "The Evolution of Meander Bends of the Mississippi River," In: Yalin, M.S. (Chair), *Hydraulics and the Environment, Proceedings of the XXIII Congress of the IAHR*, Vol. B, Fluvial Hydraulics, p. B33-B39.
109. Hooke, J.M., 1995, "Processes of Channel Planform Change on Meandering Channels in the U.K.," In: Gurnell, A. and Petts, G. (eds.), *Changing River Channels*, John Wiley and Sons, Chichester, UK, p. 87-115.
110. Howard, A.D., 1996, "Modeling Channel Evolution and Floodplain Morphology," In: Anderson, M.G., Walling, D.E., and Bates, P.D. (eds.), *Floodplain Processes*, John Wiley and Sons, Chichester, UK, p. 15-62.
111. Biedenharn, D., Rappett, N., and Montague, C., 1984, "Long-term Stability of the Ouchita River," In: Elliott, C.M. (ed.), *River Meandering, Proceedings of the Conference Rivers '83*, New Orleans, LA, p. 126-137.
112. Swanson, J.E., 1984, "Tazlina River Meanders Loop: A Case History," In: Elliott, C.M. (ed.), *River Meandering, Proceeding of the Conference Rivers '83*, New Orleans, LA, p. 231-239.
113. Thorne, C.R. and Osman, A.M., 1988, "The Influence of Bank Stability on Regime Geometry of Natural Channels," In: White, W.R. (ed.), *International Conference on River Regime*, Hydraulics Research Limited, John Wiley and Sons, Chichester, UK, p. 135-147.
114. Thorne, C.R. and Osman, A.M., 1988, "Riverbank Stability Analysis II: Applications," *Journal Hydraulic Engineering*, ASCE, Vol. 114, p. 151-172.
115. Kornis, A., 1980, "Meander Travel in Alluvial streams," In: Garde, R.J. (Chair), *Proceedings of the International Workshop on Alluvial River Problems*, Roorkee, India, p. 4.35-4.41.
116. Ackers, P. and Charlton, F.G., 1970, "Meander Geometry Arising from Varying Flows," *Journal of Hydrology*, ASCE, Vol. II, No. 3, p. 230-252.
117. Hughes, D.J., 1977, "Rates of Erosion on Meander Arcs," In: Gregory, K.J. (ed.), *River Channel Changes*, John Wiley and Sons, Chichester, UK, p. 193-205.
118. Schumm, S.A., 1968, "River Adjustment to Altered Hydrologic Regimen - Murrumbidgee River and Paleochannels, Australia," U.S. Geological Survey Professional Paper 598, 65 p.

119. Daniel, J.F., 1971, "Channel Movement of Meandering Indiana Streams," U.S. Geological Survey Prof. Paper 732-A, 18 p.
120. Hooke, J.M., 1980, "Magnitude and Distribution of Rates of River Bank Erosion," *Earth Surface Processes*, Vol. 5, No. 2, pp. 143-157.
121. Laczay, I.A., 1977, "Channel Pattern Changes of Hungarian rivers: The Example of the Hernád River," In: Gregory, K.J. (ed.), *River Channel Changes*, John Wiley and Sons, Chichester, UK, p. 185-192.
122. Hagerty, D.J., Sharifounnasab, M., and Spoor, M.F., 1983, "River Bank Erosion: A Case Study," *Bulletin American Association Eng. Geol.*, Vol. XX, No. 4, p. 411-437.
123. Nagabhushanaiah, H.S., 1967, "Meandering of Rivers," *Bulletin of the International Association of Scientific Hydrology*, Vol. 12, No. 1, pp. 28-43.
124. Van der Berg, J.H., 1995, "Prediction of Alluvial Channel Pattern of Perennial Rivers," *Geomorphology*, Vol. 12, p. 259-279.
125. Lewin, J., 1983, "Changes of Channel Patterns and Floodplains," In: Gregory, K.J. (ed.), *Background to Paleohydrology*, John Wiley and Sons, Chichester, UK, p. 303-319.
126. Schumm, S.A., 1977, "The Fluvial System," John Wiley and Sons, New York, 338 p.
127. Martinson, H.A., 1984, "Channel Changes of Powder River Between Moorhead and Broadus, Montana, 1939 to 1978," U.S. Geological Survey Water Resources Investigations, WRI 83-4128, 62 p.
128. Hooke, J.M., 1984, "Meander Behavior in Relation to Slope characteristics," In: Elliott, C.M. (ed.), *River Meandering, Proceedings of the Conference Rivers '83*, New Orleans, LA, p. 67-76.
129. Schumm, S.A., Gregory, D.I., Lattman, L.H., and Watson, C.C., 1984, "River Response to Active Tectonics," Final Report, Phase I to National Science Foundation, 124 p.
130. Rhoads, B.L. and Miller, M.V., 1991, "Impact of Flow Variability on the Morphology of a Low-Energy Meandering River," *Earth Surface Processes and Landforms*, Vol. 16, No. 4, p. 357-367.
131. Ackers, P. and Charlton, F.G., 1975, "Theories and Relationships of River Channel Patterns, a Discussion," *Journal of Hydrology*, ASCE, Vol. 26, No. 3-4, p. 359-362.
132. Neill, C.R., 1984, "Bank Erosion Versus Bedload Transport in a Gravel River," In: Elliott, C.M. (ed.), *River Meandering*, American Society of Civil Engineers, New York, p. 204-211.

133. Brook, G.A. and Luft, E.R., 1987, "Channel Pattern Changes Along the Lower Oconee River, Georgia, 1805/1807 to 1949," *Physical Geography*, 8(3), p. 191-209.
134. Burke, T.D., 1984, "Channel Migration on the Kansas River," In: Elliott, C.M. (ed.), *River Meandering, Proceedings of the Conference Rivers '83*, New Orleans, LA, p. 250-258.
135. Chang, H.H., 1984, "Meandering of Underfit Streams," *Journal of Hydrology*, Vol. 75, No. 1-4, p. 311-322.
136. Yen, C. and Ho, S., 1990, "Bed Evolution in Channel Bends," *Journal Hydraulic Engineering*, Vol. 116, p. 544-562.
137. Hasegawa, K., 1989, "Universal Bank Erosion Coefficient for Meandering Rivers," *Journal of Hydraulic Engineering*, 115(6), 744-765.
138. Lawler, D.M., 1987, "Bank Erosion and Frost Action: and Example from South Wales," In: Gardner, V. (ed.), *International Geomorphology 1986, Part 1*, John Wiley and Sons, Chichester, UK, p. 575-590.
139. Mosselman, E., Crosato, A., and Hasegawa, K., 1991, "Universal Bank Erosion Coefficient for Meandering Rivers" (discussion and closure), *Journal of Hydraulic Engineering*, Vol. 117, No. 7, pp. 942-946.
140. Thein, K.N., 1994, "River Plan-form Movement in an Alluvial Plain," Ph.D. Thesis – International Institute for Infrastructural, Hydraulics and Environmental Engineering, A.A. Balkema, Rotterdam, 319 p.
141. Chitale, S.V., 1980, "Shape and Mobility of River Meanders," *Proceedings XIX IAHR Congress*, Subject A, Vol. 2, p. 281-286.
142. Thorne, C.R., Murphy, J.B., and Little, W.C., 1981, "Bank Stability and Bank Material Properties in the Bluffline Streams of Northwest Mississippi," Appendix D, *Stream Channel Stability*, U.S. Dept. of Agriculture, Sedimentation Laboratory, Oxford, MS, 158 p.
143. Osman, A.M. and Thorne, C.R., 1988, "River Stability Analysis 1: Theory," *Journal of Hydraulic Engineering*, ASCE, Vol. 114, p. 134-150.
144. Hickin, E.J., 1984, "Vegetation and River Channel Dynamics," *The Canadian Geographer*, Vol. 28, No. 2, p. 111-126.
145. Gray, D.H. and MacDonald, A., 1989, "The Role of Vegetation in River Bank Erosion," In: Ports, M.A. (ed.), *Proceedings of the 1989 National Conference on Hydraulic Engineering*, New Orleans, LA, p. 218-223.

146. Smith, D.G., 1976, "Effect of Vegetation on Lateral Migration of Anastomosed Channels of a Glacier Meltwater River," *Geological Society of America Bulletin*, Vol. 87, p. 857-860.
147. Jacobson, R.B. and Pugh, A.L., 1998, "Riparian Vegetation Controls on the Spatial Pattern of Stream Channel Instability, Little Piney Creek, Missouri," U.S Geological Survey Water Supply Paper 2494, 33 p.
148. Petersen, M.S., 1986, "River Engineering," Prentice-Hall, Englewood Cliffs, NJ.
149. Beck, S., Melfi, D.A., and Yalamanchili, K., 1984, "Lateral Migration of the Genessee River, New York," In: Elliott, C.M. (ed.), *River Meandering, Proceedings of the Conference Rivers '83*, New Orleans, LA, p. 510-517.
150. Beeson, C.E. and Doyle, P.F., 1995, "Comparison of Bank Erosion at Vegetated and Non-vegetated Channel Bends," *Water Resources Bulletin*, Vol. 31, No. 6, p. 983-990.
151. Burckhardt, J.D. and Todd, B.L., 1998, "Riparian Forest Effect on Lateral Stream Channel Migration in the Glacial Till Plains," *Journal American Water Resources Association*, Vol. 34, p. 179-184.
152. Murgatroyd, A.L. and Ternan, J.L., 1983, "The Impact of Afforestation on Stream Bank Erosion and Channel Form," *Earth Processes and Landforms*, Vol. 8, No. 4, p. 357-369.
153. Jones, J.A.A., 1989, "Bank Erosion; a Review of British Research," In: Ports, M.A. (ed.), *Proceedings of the 1989 National Conference on Hydraulic Engineering*, New Orleans, LA, p. 283-288.
154. Bradley, C. and Smith, D.G., 1984, "Meandering Channel Response to Altered Flow Regime; Milk River, Alberta," *Water Resources Research*, Vol. 20, No. 12, pp. 1913-1920.
155. Williams, G.P. and Wolman, M.G., 1984, "Downstream Effects of Dams on Alluvial Rivers," U.S. Geological Survey Professional Paper 1286.
156. Akashi, Y., 1988, "Riparian Vegetation Dynamics Along the Bighorn River," Wyoming, Masters Thesis, University of Wyoming, Laramie, WY.
157. Gillespie, B.M. and Giardino, J.R., 1996, "Determining the Migratory Activity Index for a River: An Example from the Brazos River, Texas," *Zeitschrift für Geomorphologie* 40, p. 417-428.
158. Rood, S.B. and Mahoney, J.M., 1995, "River Damming and Riparian Cottonwoods Along the Marias River," *Montana, Rivers* (5), p. 195-207.

159. Friedman, J.M., Osterkamp, W.R., Scott, M.L., and Auble, G.T., 1998, "Downstream Effects of Dams on Channel Geometry and Bottomland Vegetation, Regional Patterns in the Great Plains," *Wetlands*, Vol. 18, p. 619-633.
160. Hooke, J.M., 1977, "The Distribution and Nature of Changes in River Channel Patterns: The Example of Devon," In: Gregory, K.J. (ed.), *River Channel Changes*, John Wiley and Sons, Chichester, UK, p. 265-280.
161. Hooke, J.M. and Harvey, A.M., 1983, "Meander Changes in Relation to Bend Morphology and Secondary Flows," In: Collinson, J.D. and Lewin, L. (eds.), *Modern and Ancient Fluvial Systems*, International Assoc. Sedimentologists Special Pub. 6, p. 121-132.
162. Parker, G., 1983, "Meander Bends of High Amplitude," *Journal of Hydraulic Engineering*, ASCE, Vol. 109, No. 10, pp. 1323-1337.
163. Whiting, P.J. and Dietrich, 1993, "Experimental Studies of Bed Topography and Flow Patterns in Large Amplitude Meanders: I. Observations," *Water Resources Research*, 29 (11), 3605-3614.
164. Whiting, P.J. and Dietrich, 1993, "Experimental Studies of Bed Topography and Flow Patterns in Large Amplitude Meanders: II. Mechanisms," *Water Resources Research*, 29 (11), 3615-3622.
165. Paine, A.D.M., 1985, "Ergodic Reasoning in Geomorphology: A Preliminary Review," *Prog. Phys. Geogr.*, Vol. 9, p. 1-15.
166. Wolman, M.G. and Gerson, R., 1978, "Relative Scales of Time and Effectiveness of Climate in Watershed Geomorphology," *Earth Surface Proceedings*, Vol. 3, p. 189-208.
167. Abrahams, A.D., 1972, "Drainage Densities and Sediment Yields in Eastern Australia," *Austr. Geogr. Studies*, Vol. 10, p. 19-41.
168. Thornes, J.B. and Brunsden, D., 1977, "Geomorphology and Time," Methuen, London.
169. Keady, D.M. and Priest, M.S., 1977, "The Downstream Migration Rate of River Meander Patterns," *Proceedings 12th Mississippi Water Resources Conference*, Jackson, MS, p. 29-34.
170. Martin, E.H., Shen, H.W., and Glover, J.E., 1986, "Classification and Behavior of Meander Migration," In: Karamouz, M., et al. (eds.), *Water Forum '86*, ASCE, New York, p. 1694-1701.
171. Nakagawa, T., 1983, "Boundary Effects on Stream Meandering and River Morphology," *Sedimentology*, Vol. 30, No. 1, pp. 117-127.

172. Chang, H.H., 1984, "Modeling of River Channel Changes," *Journal of Hydraulic Engineering*, ASCE, Vol. 110, No. 2, pp. 157-172.
173. Cunge, J.A., 1984, "Feasibility of Mathematical Modeling of Meanders," In: Elliott, C.M. (ed.), *River Meandering, Proceedings of the Conference Rivers '83*, ASCE, New Orleans, LA, p. 794-809.
174. Sun, T., Meakin, P., Jossang, T., and Schwarz, K., 1996, "A Simulation Model for Meandering Rivers," *Water Resources Research*, Vol. 32, No. 9, p. 2937-2954.
175. Howard, A.D. and Knutson, T.R., 1984, "Sufficient Conditions for River Meandering: A Simulation Approach," *Water Resources Research*, Vol. 20, p. 1659-1667.
176. Ligeng, L. and Schiara, M., 1989, "Meander Bend Expansion and Meander Amplitude Development: Theoretical Models," In: Ding Lianzhen (Chair), *Proceedings of the Fourth International Symposium on River Sedimentation*, Beijing, China, p. 857-864.
177. Levent, V., 1991, "Meander Bend Expansion and Meander Amplitude Development," In: Fan, S.S., and Kuo, Y.H. (eds.), *Proceedings of the Fifth Federal Interagency Sedimentation Conference*, Las Vegas, NV, p. 3.118-3.125.
178. Mosselman, E., 1995, "A Review of Mathematical Models of River Planform Changes," In: Thorne, C.R. and Thompson, A. (eds.), *Geomorphology at Work, Earth Surface Processes and Landforms*, Vol. 20, No. 7, p. 661-670.
179. Darby, S.E., 1998, "River Width Adjustment II: Modeling," In: Thorne, C.R. (Chair), American Society of Civil Engineers Task Committee on Hydraulics, Bank Mechanics and Modeling of River Width Adjustment, *Journal of Hydraulic Engineering*, 124(9), 903-917.
180. Parker, G., Sawai, K., and Ikeda, S., 1982, "Bend Theory of River Meanders, Part 2, Nonlinear Deformation of Finite Amplitude Bends," *Journal Fluid Mechanics*, Vol. 115, p. 303-314.
181. Ferguson, R.I., 1984, "Kinematic Model of Meander Migration," In: Elliott, Charles M. (ed.), *River Meandering, Proceedings of the Conference Rivers '83*, New Orleans, LA, p. 942-951.
182. Crosato, A., 1990, "Simulation of Meandering River Processes, Communications on Hydraulic and Geotechnical Engineering," 90-3, Delft University of Technology.
183. Howard, A.D., 1992, "Modeling Channel Migration and Floodplain Sedimentation in Meandering Streams," In: Carling, P.A. and Petts, G.E. (eds.), *Lowland Floodplain Rivers*, John Wiley and Sons, Chichester, UK, 1-42.

184. Blondeaux, P. and Seminara, G., 1984, "Bed Topography and Instabilities in Sinuous Channels," In: Elliott, C.M. (ed.), *River Meandering, Proceedings of the Conference Rivers '83*, New Orleans, LA, 747-758.
185. Nelson, J.M. and Smith, J.D., 1989, "Flow in Meandering Channels With Natural Topography," In: Ikeda, S. and Parker, G. (eds.), *River Meandering*, AGU Water Resources Monograph, 12, 69-102.
186. Johansson, H. and Parker, G., 1989, "Computer Simulated Migration of Meandering Rivers in Minnesota," Project report 242, St. Anthony Falls Laboratory, Univ. Minnesota, 82p.
187. Falcon, M.A. and Kennedy, J.F., 1983, "Flow in Alluvial River Curves," *Journal of Fluid Mechanics*, 133 p.
188. Bridge, J.S., 1982, "A Revised Mathematical Model and FORTRAN IV Program to Predict Flow, Bed Topography, and Grain Size in Open Channel Bends," *Computers and Geosciences*, 8, 91-95.
189. Simon, A. and Darby, S.E., 1997, "Process-form Interactions in Unstable Sand-bed River Channels: A Numerical Modeling Approach," *Geomorphology*, 21, 85-106.
190. Darby, S.E. and Thorne, C.R., 1993, "Approaches to Modeling Width Adjustment in Curved Alluvial Channels," Working Paper 20, Department of Geography, University of Nottingham, 90p.
191. Simon, A., 1992, "Energy, Time and Channel Evolution in Catastrophically Disturbed Fluvial Systems," In: Philips, J.D. and Renwick, W.H. (eds.), *Geomorphic Systems, Proceedings 23rd Binghamton Symposium*, 345-373.
192. Simon, A. and Thorne, C.R., 1996, "Channel Adjustment of an Unstable Coarse-grained Stream: Opposing Trends of Boundary and Critical Shear Stress, and the Applicability of Extremal Hypotheses," *Earth Surface Processes and Landforms*, Vol. 21, No. 2, 155-180.
193. Darby, S.E., Thorne, C.R., and Simon, A., 1996, "Numerical Simulation of Widening and Bed Deformation of Straight Sand-bed Rivers II: Model Evaluation," *Journal of Hydraulic Engineering*, 122(4), p. 194-202.
194. ASCE, 1998a, "River Width Adjustment I: Processes and Mechanisms," In: Thorne, C.R. (Chair), American Society of Civil Engineers Task Committee on Hydraulics, Bank Mechanics and Modeling of River Width Adjustment, *Journal of Hydraulic Engineering*, 124(9), 881-902.

195. ASCE, 1998b, "River Width Adjustment II: Modeling," In: Thorne, C.R. (Chair), American Society of Civil Engineers Task Committee on Hydraulics, Bank Mechanics and Modeling of River Width Adjustment, *Journal of Hydraulic Engineering*, 124(9), 903-917.
196. Andrie, R., 1996, "Measuring Channel Planform of Meandering Rivers," *Physical Geogr.*, Vol. 17, p. 270-281.
197. Downward, S.R., Gurnell, A.M., and Brookes, A., 1995, "A Methodology for Quantifying River Channel Planform Change Using GIS Variability," In: Olive, J.S., Loughrau, R.J., and Kesby, J.A. (eds.), *Variability in Stream Erosion and Sediment Transport*, IAHS-AISH Pub. 224, p. 449-456.
198. Gurnell, A.M., Bickerton, M., Angold, P., Bell, D., Morrissey, I., Petts, G.E., and Sadler, J., 1998, "Morphological and Ecological Change on a Meander Bend; the Role of Hydrological Processes and the Application of GIS," In: Gurnell, A.M. and Montgomery, D. (eds.), *Hydrological Applications of GIS-1, Hydrological Processes*, Vol. 12, No. 6, pp. 981-993.
199. Federal Emergency Management Agency, 1999, "Riverine Erosion Hazard Areas – Mapping Feasibility Study," Technical Services Division, Hazards Study Branch, Washington, D.C.
200. Thorne, C.R., 1997, "Channel Types and Morphological Classification," Chapter 7 In: C.R. Thorne, R.D. Hey, and M.D. Newsom (eds.), *Applied Fluvial Geomorphology for River Engineering and Management*, John Wiley and Sons, Chichester, UK.
201. Lagasse, P.F., Schall, J.D., and Richardson, E.V., 2001, "Stream Stability at Highway Structures," *Hydraulic Engineering Circular 20*, Third Edition, FHWA NHI 01-002, Federal Highway Administration, U.S. Department of Transportation, Washington, D.C.
202. Schumm, S.A. and Kahn, H.R., 1972, "Experimental Study of Channel Patterns," *Geological Society of America Bulletin*, Vol. 83, p. 1755-1700.
203. Shen, H.W., Schumm, S.A., Nelson, J.D., Doehring, D.O., and Skinner, M.M., 1983, "Methods for Assessment of Stream-Related Hazards to Highways and Bridges," FHWA/RD-80/160, Federal Highway Administration, Washington, D.C.
204. Schumm, S.A., 1981, "Evolution and Response of the Fluvial System," *Sedimentologic Implications: SEPM Special Publication 31*, p. 19-29.
205. Montgomery, D.R. and Buffington, J.M., 1997, "Channel-reach Morphology in Mountain Drainage Basins," *Geological Society of America Bulletin*, Vol. 109, No. 5, p. 596-611.
206. Rosgen, D.L., 1994, "A Classification of Natural Rivers," *Catena*, Vol. 22, p. 169-199.

207. Rosgen, D.L., 1996, "Applied River Morphology," Wildland Hydrology, 1481 Stevens Lake Road, Pagosa Springs, CO 81147, USA.
208. Williams, G.P., 1978, "The Case of the Shrinking Channels – the North Platte and Platte Rivers in Nebraska," United States Geological Survey Circular 781.
209. Burkham, D.E., 1972, "Channel Changes of the Gila River in Safford Valley, Arizona, 1846-1970," United States Geological Survey Professional Paper 655-G.
210. Ruhe, R.V., 1975, *Geomorphology*, Houghton Mifflin, Boston, MA.
211. Water Engineering & Technology, Inc. (WET), 1988, "Geomorphic Analysis of Sacramento River, Phase I Report: Geomorphic Analysis of Butte Basin Reach, River Mile 174 to River Mile 194," prepared for U.S. Army Corps of Engineers, Sacramento District, Contract No. DACW05-87-C-0094.
212. Water Engineering & Technology, Inc. (WET), 1990, "Geomorphic Analysis of Sacramento River, Phase II Report: Geomorphic Analysis of Reach from Colusa to Red Bluff Diversion Dam, River Mile 143 to River Mile 243," prepared for U.S. Army Corps of Engineers, Sacramento District, Contract No. DACW05-87-C-0094.
213. Brice, J.C. and Blodgett, J.C., 1978, "Countermeasures for Hydraulic Problems at Bridges: Vol. 2, Case Histories for Sites 1-283," Federal Highway Administration Report No. FHWA-RD-78-162, 542 p.
214. Schumm, S.A., 1960, "The Shape of Alluvial Channels in Relation to Sediment Type," USGS Prof. Paper 352-B, pp. 17-30.
215. U.S. Army Corps of Engineers (USACE) Kansas City District, 1979, "Channel Migration Investigation: Historic Channel Change Maps, Kansas River and Tributaries Bank Stabilization Component, Kansas and Osage Rivers, Kansas Study," Geomorphology Laboratory, Dept. of Geology, University of Kansas.
216. MacDonald, T.E, Parker, G., and Leuthe, D.P., 1991, "Inventory and Analysis of Stream Meander Problems in Minnesota," St. Anthony Falls Hydraulic Laboratory Project Report No. 321, 38 p.
217. Water Engineering & Technology, Inc. (WET), 1986, "Investigation of Hydrologic, Geomorphic, and Sedimentologic Characteristics of the Alabama River," U.S. Army Corps of Engineers, Mobile District, DACW01-85-D-0018, Mobile, AL.
218. California Department of Water Resources (DWR), 1984, "River Atlas: Appendix to Middle Sacramento River Spawning Gravel Study," The Resource Agency, 34 sheets, Scale 1:12,000.

219. Odgaard, A.J., 1984, "Bank Erosion Contribution to Stream Sediment Load," Iowa Institute of Hydraulic Research Report No. 280, 92 p.
220. U.S. Army Corps of Engineers (USACE) Rock Island District, 1979, "Des Moines River Bank Erosion Study, Iowa and Missouri: Stage 2, Final Feasibility Report," Rock Island, IL.
221. Mussetter Engineering Inc., 1996, "Valuation of Potential Effects of Subsidence on the Genesee River and Tributaries," Report submitted to: Akzo Nobel Salt, Inc., Clarks Summit, PA.
222. Miller, J.R. and Ritter, J.B., 1996, "An Examination of the Rosgen Classification of Natural Rivers," discussion in *Catena*, Vol. 27, p. 295-299.
223. Wolf, P.R. and Dewitt, B.A., 2000, "Elements of Photogrammetry with Applications in GIS," Third Edition, McGraw-Hill, Boston, 608 pp.
224. Richardson, E.V., Simons, D.B., and Lagasse, P.F., 2001, "River Engineering for Highway Encroachments - Highways in the River Environment," Report FHWA NHI 01-004, Federal Highway Administration, Hydraulic Design Series No. 6, Washington, D.C.
225. Vanoni, V.A. (ed.), 1975, 1977, "Sedimentation Engineering," ASCE Manuals and Reports on Engineering Practice – No. 54, Reston, VA.
226. Chang, F.F.M., 1973, "A Statistical Summary of the Cause and Cost of Bridge Failures," Federal Highway Administration, U.S. Department of Transportation, Washington, D.C.
227. Rhodes, J. and Trent, R., 1993, "Economics of Floods, Scour, and Bridge Failures," *Hydraulic Engineering*, ASCE, Proceeding of the 1993 National Conference, Vol. 1, pp. 928-933.

APPENDIX A

BIBLIOGRAPHY

Abrahams, A.D., 1972, "Drainage Densities and Sediment Yields in Eastern Australia," *Austr. Geogr. Studies*, Vol. 10, p. 19-41.

Ackers, P. and Charlton, F.G., 1970, "Meander Geometry Arising from Varying Flows," *Journal of Hydrology*, ASCE, Vol. II, No. 3, p. 230-252.

Ackers, P. and Charlton, F.G., 1975, "Theories and Relationships of River Channel Patterns, a Discussion," *Journal of Hydrology*, ASCE, Vol. 26, No. 3-4, p. 359-362.

Akashi, Y., 1988, "Riparian Vegetation Dynamics Along the Bighorn River," Wyoming, Masters Thesis, University of Wyoming, Laramie, WY.

Alabyan, A.M. and Chalor, R.S., 1998, "Types of River Channel Patterns and Their Natural Controls," *Earth Surface Processes and Landforms*, Vol. 23, p. 467-474.

Andrle, R., 1996, "Measuring Channel Planform of Meandering Rivers," *Physical Geogr.*, Vol. 17, p. 270-281.

ASCE, 1998a, "River Width Adjustment I: Processes and Mechanisms," In: Thorne, C.R. (Chair), American Society of Civil Engineers Task Committee on Hydraulics, Bank Mechanics and Modeling of River Width Adjustment, *Journal of Hydraulic Engineering*, 124(9), 881-902.

ASCE, 1998b, "River Width Adjustment II: Modeling," In: Thorne, C.R. (Chair), American Society of Civil Engineers Task Committee on Hydraulics, Bank Mechanics and Modeling of River Width Adjustment, *Journal of Hydraulic Engineering*, 124(9), 903-917.

Ashworth P., Bennett, S., Best, J., and McLelland, S., 1996, "Coherent Flow Structures in Open Channels," John Wiley and Sons, Chichester, UK.

Bagnold, R.A., 1960, "Some Aspects of the Shape of River Meanders," USGS Prof. Paper 181E, p. 135-144.

Bathurst, J.C., Thorne, C.R., and Hey, R.D., 1977, "Direct Measurements of Secondary Currents In River Bends," *Nature*, Vol. 269, No. 5628, 504-506

Bathurst, J.C., Thorne, C.R., and Hey, R.D., 1979, "Secondary Flow and Shear Stress at River Bends," *Journal of the Hydraulics Division*, ASCE, Vol. 10, Proc. Paper 14906, pp. 1277-1295, and discussion Vol. 106, No. HY10, pp. 1710-1713 and Closure, Vol. 107, HY5, 644-647.

Beck, S., Melfi, D.A., and Yalamanchili, K., 1984, "Lateral Migration of the Genessee River, New York," In: Elliott, C.M. (ed.), *River Meandering, Proceedings of the Conference Rivers '83*, New Orleans, LA, p. 510-517.

Beeson, C.E. and Doyle, P.F., 1995, "Comparison of Bank Erosion at Vegetated and Non-vegetated Channel Bends," *Water Resources Bulletin*, Vol. 31, No. 6, p. 983-990.

Begin, Ze'ev B., 1986, "Curvature Ratio and Rate of River Bend Migration Update," *Journal of Hydraulic Engineering*, Vol. 112, No. 10, p. 904-908.

Biedenharn, D., Raphett, N., and Montague, C., 1984, "Long-term Stability of the Ouchita River," In: Elliott, C.M. (ed.), *River Meandering, Proceedings of the Conference Rivers '83*, New Orleans, LA, p. 126-137.

Biedenharn, D.S., Combs, P., Hill, G.J., Pinkard, C., and Fred, Jr., Pinkston, C.B., 1989, "Relationship Between Channel Migration and Radius of Curvature on the Red River," *Proceedings of the International Symposium on Sediment Transport Modeling*, p. 536-541.

Blondeaux, P. and Seminara, G., 1984, "Bed Topography and Instabilities in Sinuous Channels," In: Elliott, C.M. (ed.), *River Meandering, Proceedings of the Conference Rivers '83*, New Orleans, LA, 747-758.

Bradley, C. and Smith, D.G., 1984, "Meandering Channel Response to Altered Flow Regime; Milk River, Alberta," *Water Resources Research*, Vol. 20, No. 12, pp. 1913-1920.

Braga, G. and Gervasoni, S., 1989, "Evolution of the Po River: An example of the Application of Historic Maps," In: Petts, G.E., Möller, H., and Roux, A.L. (eds.), *Historical Change of Large Alluvial Rivers: Western Europe*, John Wiley and Sons, New York, p. 113-126.

Brice, J.C., 1974, "Evolution of Meander Loops," *Geological Society of America Bulletin*, Vol. 85, p. 581-586.

Brice, J.C., 1975, "Air Photo Interpretation of the Form and Behavior of Alluvial Rivers," final report to the U.S. Army Research Office, Washington, D.C.

Brice, J., 1977, "Lateral Migration of the Middle Sacramento River, California," USGS Water Resources Investigation 77-43, 51 p.

Brice, J.C., 1982, "Stream Channel Stability Assessment," Federal Highway Administration Report RHWA/RD-82/021, 41 p.

Brice, J.C., 1984, "Planform Properties of Meandering Rivers," In: Elliott, C.M. (ed.), *River Meandering, Proceedings of the Conference Rivers '83*, New Orleans, LA, p. 1-15.

Brice, J.C. and Blodgett, J.C., 1978, "Countermeasures for Hydraulic Problems at Bridges: Vol. 2, Case Histories for Sites 1-283," Federal Highway Administration Report No. FHWA-RD-78-162, 542 p.

Brice, J.D., 1983, "Factors in Stability of Relocated Channels," *Journal of Hydraulic Engineering*, ASCE, Vol. 109, No. 10, pp. 1298-1313.

Bridge, J.S., 1982, "A Revised Mathematical Model and FORTRAN IV Program to Predict Flow, Bed Topography, and Grain Size in Open Channel Bends," *Computers and Geosciences*, 8, 91-95.

Brook, G.A. and Luft, E.R., 1987, "Channel Pattern Changes Along the Lower Oconee River, Georgia, 1805/1807 to 1949," *Physical Geography*, 8(3), p. 191-209.

Burckhardt, J.D. and Todd, B.L., 1998, "Riparian Forest Effect on Lateral Stream Channel Migration in the Glacial Till Plains," *Journal American Water Resources Association*, Vol. 34, p. 179-184.

Burke, T.D., 1984, "Channel Migration on the Kansas River," In: Elliott, C.M. (ed.), *River Meandering, Proceedings of the Conference Rivers '83*, New Orleans, LA, p. 250-258.

Burkham, D.E., 1972, "Channel Changes of the Gila River in Safford Valley, Arizona, 1846-1970," United States Geological Survey Professional Paper 655-G.

California Department of Water Resources (DWR), 1984, "River Atlas: Appendix to Middle Sacramento River Spawning Gravel Study," The Resource Agency, 34 sheets, Scale 1:12,000.

Carey, W.C., 1969, "Formation of Floodplain Lands," *Journal of Hydraulic Engineering*, ASCE, Vol. 95.

Carlston, C.W., 1965, "The Relation of Free Meander Geometry to Stream Discharge and its Geomorphic Implications," *American Journal Science* 263, 864-85.

Carson, M.A., 1986, "Characteristics of High-energy Meandering Rivers," The Canterbury Plains, New Zealand, *Geological Society of America Bulletin*, Vol. 97, p. 886-895.

Carson, M.A. and Lapointe, M.F., 1983, "The Inherent Asymmetry of River Meander Planform," *Journal Geology*, Vol. 91, p. 41-55.

Chang, F.F.M., 1973, "A Statistical Summary of the Cause and Cost of Bridge Failures," Federal Highway Administration, U.S. Department of Transportation, Washington, D.C.

Chang, H.H., 1984, "Analysis of River Meanders," ASCE, *Journal of Hydraulic Engineering*, Vol. 110, No. 1, pp. 37-50.

Chang, H.H., 1984, "Meandering of Underfit Streams," *Journal of Hydrology*, Vol. 75, No. 1-4, p. 311-322.

Chang, H.H., 1984, "Modeling of River Channel Changes," *Journal of Hydraulic Engineering*, ASCE, Vol. 110, No. 2, pp. 157-172.

Chang, H.H., 1988, "Processes of Meander Bend Migration," Discussion of effect of flow paths on migration of symmetrical meanders, In: Abt, S.R. and Gessler, J. (eds.), *Proceedings 1988 ASCE Conference*, Hydraulic Engineering, p. 690-695.

Chang, T.P. and Toebes, G.H., 1970, "A Statistical Comparison of Meander Planforms in the Wabash Basin," *Water Resources Research*, Vol. 6, No. 2, p. 557-578.

Chang, T.P. and Toebes, G.H., 1980, "Geometric Parameters for Alluvial Rivers Related to Regional Geology," *Proceedings International Association for Hydraulic Research Congress 14*, Vol. 3, p. 192-201.

Cherry, D.S., Wilcock, P.R., and Wolman, M.G., 1996, "Evaluation of Methods for Forecasting Planform Change and Bankline Migration in Flood-control Channels," Department of Geography and Environmental Engineering, Johns Hopkins University, prepared for U.S. Army Engineer Waterways Experiment Station, Vicksburg, MS.

Chitale, S.V., 1980, "Shape and Mobility of River Meanders," *Proceedings XIX IAHR Congress*, Subject A, Vol. 2, p. 281-286.

Crosato, A., 1990, "Simulation of Meandering River Processes, Communications on Hydraulic and Geotechnical Engineering," 90-3, Delft University of Technology.

Cunge, J.A., 1984, "Feasibility of Mathematical Modeling of Meanders," In: Elliott, C.M. (ed.), *River Meandering, Proceedings of the Conference Rivers '83*, ASCE, New Orleans, LA, p. 794-809.

Daniel, J.F., 1971, "Channel Movement of Meandering Indiana Streams," U.S. Geological Survey Prof. Paper 732-A, 18 p.

Darby, S.E., 1998, "River Width Adjustment II: Modeling," In: Thorne, C.R. (Chair), American Society of Civil Engineers Task Committee on Hydraulics, Bank Mechanics and Modeling of River Width Adjustment, *Journal of Hydraulic Engineering*, 124(9), 903-917.

Darby, S.E. and Thorne, C.R., 1993, "Approaches to Modeling Width Adjustment in Curved Alluvial Channels," Working Paper 20, Department of Geography, University of Nottingham, 90p.

Darby, S.E., Thorne, C.R., and Simon, A., 1996, "Numerical Simulation of Widening and Bed Deformation of Straight Sand-bed Rivers II: Model Evaluation," *Journal of Hydraulic Engineering*, 122(4), p. 194-202.

Davies, T.R.H., and Tinker, C.C., 1984, "Fundamental Characteristics of Stream Meanders," *Geological Society of America Bulletin*, Vol. 95, No. 5, pp. 505-512.

Davis, D.H., 1908, "A Study of River Meanders on the Middle Rouge (Michigan)," *Journal of Geology*, p. 755-764.

Decamps, H., Fortune, M., and Gazelle, F., 1989, "Historical Changes of the Garonne River, Southern France," In: Petts, G.E., Möller, H., and Roux, A.L. (eds.), *Historical Change of Large Alluvial Rivers: Western Europe*, John Wiley and Sons, New York, p. 249-267.

Dietrich, W.E. and Smith, J.D., 1983, "Influence of the Point Bar on Flow Through Curved Channels," *Water Resources Research*, Vol. 19, p. 1173-1192.

Dietrich, W.E., Smith, J.D., and Dunne, T., 1984, "Boundary Shear Stress, Sediment Transport and Bed Morphology in a Sand-Bedded River Meander During High and Low Flow," In: Elliott, C.M. (ed.) *River Meandering, Proceedings of the Conference Rivers '83*, New Orleans, LA, p. 632-639.

Dort, W., Jr., 1978, "Channel Migration Investigation, Historic Channel Change Maps, Kansas River and Tributaries Bank Stabilization Component, Kansas and Osage Rivers," Kansas Study, U.S. Army Corps of Engineers, Kansas City District.

Downward, S.R., Gurnell, A.M., and Brookes, A., 1995, "A Methodology for Quantifying River Channel Planform Change Using GIS Variability," In: Olive, J.S., Loughrau, R.J., and Kesby, J.A. (eds.), *Variability in Stream Erosion and Sediment Transport*, IAHS-AISH Pub. 224, p. 449-456.

Einstein, H.A. and Shen, H.W., 1964, "A Study of Meandering in Straight Alluvial Channels," *Journal of Geophysical Research*, 69, pp. 5329-5347.

Elliott, C.M. (ed.), 1984, "River Meandering," *Proceedings of the Conference Rivers '83*, New Orleans, LA, 1036p.

Engelund, F., 1974, "Flow and Bed Topography in Channel Bends," *Journal Hydraulics*, Vol. 100, p. 1631-1648.

Falcon, M.A. and Kennedy, J.F., 1983, "Flow in Alluvial River Curves," *Journal of Fluid Mechanics*, 133 p.

Federal Emergency Management Agency, 1999, "Riverine Erosion Hazard Areas – Mapping Feasibility Study," Technical Services Division, Hazards Study Branch, Washington, D.C.

Ferguson, R.I., 1973, "Regular Meander Path Models," *Water Resources Research*, Vol. 9, p. 1079-1086.

Ferguson, R.I., 1977, "Meander Sinuosity and Direction Variance," *Geological Society of America Bulletin*, Vol. 88, p. 212-214.

Ferguson, R.I., 1984, "Kinematic Model of Meander Migration," In: Elliott, Charles M. (ed.), *River Meandering, Proceedings of the Conference Rivers '83*, New Orleans, LA, p. 942-951.

Fisk, H.N., 1944, "Fine-grained Alluvial Deposits and their Effects on Mississippi River Activity," U.S. Army Eng. Waterways Expr. Sta., Vol. 2., Vicksburg, MS.

Friedkin, J.F., 1945, "A Laboratory Study of the Meandering of Alluvial Rivers," U.S. Army Engineers Waterways Experiment Station, Vicksburg, MS.

Friedman, J.M., Osterkamp, W.R., Scott, M.L., and Auble, G.T., 1998, "Downstream Effects of Dams on Channel Geometry and Bottomland Vegetation, Regional Patterns in the Great Plains," *Wetlands*, Vol. 18, p. 619-633.

Furbish, D.J., 1988, "River-bend Curvature and Migration: How are They Related?," *Geology*, Vol. 16, p. 752-755.

Furbish, D.J., 1991, "Spatial Autoregressive Structure in Meander Migration," *Geological Society of America Bulletin*, Vol. 103, p. 1576-1589.

Garcia, M.H., Bittner, L., and Nino, Y., 1994, "Mathematical Modeling of Meandering Streams in Illinois: A Tool for Stream Management and Engineering," Dept. Civil Engineering, University of Illinois at Urbana-Champaign, Urbana, IL.

Gillespie, B.M. and Giardino, J.R., 1996, "Determining the Migratory Activity Index for a River: An Example from the Brazos River, Texas," *Zeitschrift für Geomorphologie* 40, p. 417-428.

Gottesfeld, A.S. and Johnson-Gottesfeld, L.M., 1990, "Floodplain Dynamics of a Wandering River, Dendrochronology of the Morice River," British Columbia, Canada, *Geomorphology*, Vol. 3, No. 2, p. 159-179.

Gray, D.H. and MacDonald, A., 1989, "The Role of Vegetation in River Bank Erosion," In: Ports, M.A. (ed.), *Proceedings of the 1989 National Conference on Hydraulic Engineering*, New Orleans, LA, p. 218-223.

Gurnell, A.M., Bickerton, M., Angold, P., Bell, D., Morrissey, I., Petts, G.E., and Sadler, J., 1998, "Morphological and Ecological Change on a Meander Bend; the Role of Hydrological Processes and the Application of GIS," In: Gurnell, A.M. and Montgomery, D. (eds.), *Hydrological Applications of GIS-1, Hydrological Processes*, Vol. 12, No. 6, pp. 981-993.

Hagerty, D.J., Sharifounnasab, M., and Spoor, M.F., 1983, "River Bank Erosion: A Case Study," *Bulletin American Association Eng. Geol.*, Vol. XX, No. 4, p. 411-437.

Hakanson, L., 1973, "The Meandering of Alluvial Rivers, *Nordic Hydrology*, Vol. 4, No. 2, p. 119-128.

Harvey, M.D., 1989, "Meanderbelt Dynamics of the Sacramento River," *Proceedings, California Riparian Systems Conference*, USDA Forest Service General Technical Report PSW-110, 54-61.

Hasegawa, K., 1989, "Universal Bank Erosion Coefficient for Meandering Rivers," *Journal of Hydraulic Engineering*, 115(6), 744-765.

Henderson, F.M., 1966, "Open Channel Flow," New York, MacMillan, 522 p.

Hey, R.D., 1984, "Plan Geometry of River Meanders," In: Elliott, C.M. (ed.), *River Meandering, Proceedings of the Conferences Rivers '83*, New Orleans, LA, p. 30-43.

Hickin, E.J., 1974, "The Development of Meanders in Natural River-Channels," *American Journal of Science*, Vol. 274, p. 414-442.

Hickin, E.J., 1977, "The Analysis of River-planform Responses to Changes in Discharge," In: Gregory, K.J. (ed.), *River Channel Changes*, John Wiley and Sons, Chichester, UK, p. 249-263.

Hickin, E.J., 1978, "Hydraulic Factors Controlling Channel Migration," In: Davidson-Arnott, R. and Nickling, W. (eds.), *Research in Fluvial Geomorphology, Proceedings 5th Guelph Symposium on Geomorphology*, p. 59-66.

Hickin, E.J., 1983, "River Channel Changes: Retrospect and Prospect," In: Collinson, J.D. and Lewin, J. (eds.), *Modern and Ancient Fluvial Systems*, Basil Blackwell, Oxford, 61-83.

Hickin, E.J., 1984, "Vegetation and River Channel Dynamics," *The Canadian Geographer*, Vol. 28, No. 2, p. 111-126.

Hickin, E.J. and Nanson, G.C., 1975, "The Character of Channel Migration on the Beaton River, Northeast British Columbia, Canada," *Geological Society of America Bulletin*, Vol. 86, p. 487-494.

Hickin, E.J. and Nanson, G.C., 1984, "Lateral Migration Rates of River Bends," *Journal of Hydraulic Engineering*, ASCE, Vol. 110, No. 11, pp. 1557-1567.

Hooke, J.M., 1977, "The Distribution and Nature of Changes in River Channel Patterns: The Example of Devon," In: Gregory, K.J. (ed.), *River Channel Changes*, John Wiley and Sons, Chichester, UK, p. 265-280.

Hooke, J.M., 1980, "Magnitude and Distribution of Rates of River Bank Erosion," *Earth Surface Processes*, Vol. 5, No. 2, pp. 143-157.

Hooke, J.M., 1984, "Changes in River Meanders: A Review of Techniques and Results of Analyses," *Progress in Physical Geogr.*, Vol. 8, p. 473-508.

- Hooke, J.M., 1984, "Meander Behavior in Relation to Slope characteristics," In: Elliott, C.M. (ed.), *River Meandering, Proceedings of the Conference Rivers '83*, New Orleans, LA, p. 67-76.
- Hooke, J.M., 1991, "Non-linearity in River Meander Development: Chaos Theory and its Implications," Dept. of Geography, Univ. of Portsmouth, Working Paper 19, 13 p.
- Hooke, J.M., 1995, "Processes of Channel Planform Change on Meandering Channels in the U.K.," In: Gurnell, A. and Petts, G. (eds.), *Changing River Channels*, John Wiley and Sons, Chichester, UK, p. 87-115.
- Hooke, J.M., 1997, "Styles of Channel Change," In: Thorne, C.R., Newson, M.D., and Hey, R.D. (eds.), *Applied Fluvial Geomorphology for River Engineering and Management*, John Wiley and Sons, Chichester, UK, 237-268.
- Hooke, J.M. and Harvey, A.M., 1983, "Meander Changes in Relation to Bend Morphology and Secondary Flows," In: Collinson, J.D. and Lewin, L. (eds.), *Modern and Ancient Fluvial Systems*, International Assoc. Sedimentologists Special Pub. 6, p. 121-132.
- Hooke, J.M. and Redmond, C.E., 1989, "Use of Cartographic Sources for Analyzing River Channel Change with Examples from Britain," In: Petts, G.E. (ed.), *Historical Change of Large Alluvial Rivers: Western Europe*, John Wiley and Sons, Chichester, UK, p. 79-93.
- Hooke, J.M. and Redmond, C.E., 1992, "Causes and Nature of River Planform Changes," In: Billi, P., Hey, R.D., Thorne, C.R., and Tacconi, P. (eds.), *Dynamics of Gravel-bed Rivers*, John Wiley and Sons, Chichester, UK, p. 557-571.
- Howard, A.D., 1992, "Modeling Channel Migration and Floodplain Sedimentation in Meandering Streams," In: Carling, P.A. and Petts, G.E. (eds.), *Lowland Floodplain Rivers*, John Wiley and Sons, Chichester, UK, 1-42.
- Howard, A.D., 1996, "Modeling Channel Evolution and Floodplain Morphology," In: Anderson, M.G., Walling, D.E., and Bates, P.D. (eds.), *Floodplain Processes*, John Wiley and Sons, Chichester, UK, p. 15-62.
- Howard, A.D. and Knutson, T.R., 1984, "Sufficient Conditions for River Meandering: A Simulation Approach," *Water Resources Research*, Vol. 20, p. 1659-1667.
- Hughes, D.J., 1977, "Rates of Erosion on Meander Arcs," In: Gregory, K.J. (ed.), *River Channel Changes*, John Wiley and Sons, Chichester, UK, p. 193-205.
- Hussey, K.M. and Zimmerman, H.L., 1954, "Rate of Meander Development as Exhibited by Two Streams in Story County, Iowa," *Proceedings of the Iowa Academy of Science*, 60, p. 390-392.

- Ikeda, S. and Parker, G. (eds.), 1989, "River Meandering," AGU Water Resources Monograph 12, 485 p.
- Ikeda, S., Parker, G., and Sawai, K., 1981, "Bend Theory of River Meanders, Part 1, Linear Development," *Journal Fluid Mechanics*, Vol. 112, p. 363-377.
- Jacobson, R.B. and Pugh, A.L., 1998, "Riparian Vegetation Controls on the Spatial Pattern of Stream Channel Instability, Little Piney Creek, Missouri," U.S Geological Survey Water Supply Paper 2494, 33 p.
- Johanesson, H. and Parker, G., 1989, "Computer Simulated Migration of Meandering Rivers in Minnesota," Project report 242, St. Anthony Falls Laboratory, Univ. Minnesota, 82p.
- Jones, J.A.A., 1989, "Bank Erosion; a Review of British Research," In: Ports, M.A. (ed.), *Proceedings of the 1989 National Conference on Hydraulic Engineering*, New Orleans, LA, p. 283-288.
- Jones, L.S. and Harper, J.T., 1998, "Channel Avulsions and Related Processes, and Large-scale Sedimentation Patterns since 1875, Rio Grande," San Luis Valley, Colorado, *Geological Society of America Bulletin*, Vol. 110, p. 411-421.
- Jurado, A. and Fields, F.K., 1978, "Channel Migration of the White River in the Eastern Uinta Basin," Utah and Colorado, U.S. Geological Survey, Miscellaneous Invest. Series, I-1087.
- Keady, D.M. and Priest, M.S., 1977, "The Downstream Migration Rate of River Meander Patterns," *Proceedings 12th Mississippi Water Resources Conference*, Jackson, MS, p. 29-34.
- Keller, E.A., 1972, "Development of Alluvial Stream Channels: A Five-Stage Model," *Geological Society of America Bulletin*, Vol. 83, p. 1531-1540.
- Knighton, D., 1984, "Fluvial Forms and Processes," Edward Arnold, Baltimore, MD, 218 p.
- Kornis, A., 1980, "Meander Travel in Alluvial streams," In: Garde, R.J. (Chair), *Proceedings of the International Workshop on Alluvial River Problems*, Roorkee, India, p. 4.35-4.41.
- Laczay, I.A., 1977, "Channel Pattern Changes of Hungarian rivers: The Example of the Hernád River," In: Gregory, K.J. (ed.), *River Channel Changes*, John Wiley and Sons, Chichester, UK, p. 185-192.
- Lagasse, P.F., Schall, J.D., and Richardson, E.V., 2001, "Stream Stability at Highway Structures," Hydraulic Engineering Circular 20, Third Edition, FHWA NHI 01-002, Federal Highway Administration, U.S. Department of Transportation, Washington, D.C.
- Lapointe, M.F. and Carson, M.A., 1986, "Migration Patterns of an Asymmetric Meandering River: The Rouge River, Quebec," *Water Resources Research*, Vol. 22, No. 5, pp. 731-743.

Larsen, E. and Shen, H.W., 1989, "The Evolution of Meander Bends of the Mississippi River," In: Yalin, M.S. (Chair), *Hydraulics and the Environment, Proceedings of the XXIII Congress of the IAHR*, Vol. B, Fluvial Hydraulics, p. B33-B39.

Lawler, D.M., 1987, "Bank Erosion and Frost Action: and Example from South Wales," In: Gardner, V. (ed.), *International Geomorphology 1986*, Part 1, John Wiley and Sons, Chichester, UK, p. 575-590.

Leeder, M.R. and Bridges, P.H., 1975, "Flow Separation in Meander Bends," *Nature*, Vol. 253, p. 338-339.

Leopold, L.B. and Langbein, W.B., 1966, "River Meanders," *Scientific American*, Vol. 214, No. 6, p. 60-69.

Leopold, L.B. and Wolman, M.G., 1957, "River Channel Patterns: Braided, Meandering and Straight," U.S. Geological Survey Professional Paper 282B, 85 p.

Leopold, L.B. and Wolman, M.G., 1960, "River Meanders," *Geological Society of America Bulletin*, Vol. 71, p. 769-794.

Leopold, L.B., Wolman, M.G., and Miller, J.P., 1964, "Fluvial Processes in Geomorphology," Freeman Press, San Francisco, 522 p.

Levent, V., 1991, "Meander Bend Expansion and Meander Amplitude Development," In: Fan, S.S., and Kuo, Y.H. (eds.), *Proceedings of the Fifth Federal Interagency Sedimentation Conference*, Las Vegas, NV, p. 3.118-3.125.

Lewin, J., 1978, "Meander Development and Floodplain Sedimentation: A case study from mid-Wales," *Geology Journal*, Vol. 13, Part 1, p. 25-36.

Lewin, J., 1983, "Changes of Channel Patterns and Floodplains," In: Gregory, K.J. (ed.), *Background to Paleohydrology*, John Wiley and Sons, Chichester, UK, p. 303-319.

Lewin, J. and Brindle, B.J., 1977, "Confined Meanders," In: Gregory, K.J. (ed.), *River Channel Changes*, John Wiley and Sons, Chichester, UK, p. 221-233.

Lewis, G.W. and Lewin, J., 1983, "Alluvial Cutoffs in Wales and the Borderlands," IAS Spec. Publ. No. 6, J.D. Collinson and J. Lewin (eds.), p. 145-154.

Ligeng, L. and Schiara, M., 1989, "Meander Bend Expansion and Meander Amplitude Development: Theoretical Models," In: Ding Lianzhen (Chair), *Proceedings of the Fourth International Symposium on River Sedimentation*, Beijing, China, p. 857-864.

MacDonald, T.E, Parker, G., and Leuthe, D.P., 1991, "Inventory and Analysis of Stream Meander Problems in Minnesota," St. Anthony Falls Hydraulic Laboratory Project Report No. 321, 38 p.

Markham, A.J. and Thorne, C.R., 1992, "Geomorphology of Gravel-bed River Bends," In: P. Billi, R.D. Hey, C.R. Thorne, and Tacconi, P. (eds.), *Dynamics of Gravel-bed Rivers*, John Wiley and Sons, Chichester, UK, 433-456.

Martin, E.H., Shen, H.W., and Glover, J.E., 1986, "Classification and Behavior of Meander Migration," In: Karamouz, M., et al. (eds.), *Water Forum '86*, ASCE, New York, p. 1694-1701.

Martinson, H.A., 1984, "Channel Changes of Powder River Between Moorhead and Broadus, Montana, 1939 to 1978," U.S. Geological Survey Water Resources Investigations, WRI 83-4128, 62 p.

Martinson, H.A. and Meade, R.H., 1983, "Channel Changes of Powder River 1938-1978, Powder River Country, Montana," U.S. Geol. Survey, Hydrologic Invest. Atlas, HA-0661.

Miller, J.R. and Ritter, J.B., 1996, "An Examination of the Rosgen Classification of Natural Rivers," discussion in *Catena*, Vol. 27, p. 295-299.

Montgomery, D.R. and Buffington, J.M., 1997, "Channel-reach Morphology in Mountain Drainage Basins," *Geological Society of America Bulletin*, Vol. 109, No. 5, p. 596-611.

Mosselman, E., 1995, "A Review of Mathematical Models of River Planform Changes," In: Thorne, C.R. and Thompson, A. (eds.), *Geomorphology at Work, Earth Surface Processes and Landforms*, Vol. 20, No. 7, p. 661-670.

Mosselman, E., Crosato, A., and Hasegawa, K., 1991, "Universal Bank Erosion Coefficient for Meandering Rivers" (discussion and closure), *Journal of Hydraulic Engineering*, Vol. 117, No. 7, pp. 942-946.

Murgatroyd, A.L. and Ternan, J.L., 1983, "The Impact of Afforestation on Stream Bank Erosion and Channel Form," *Earth Processes and Landforms*, Vol. 8, No. 4, p. 357-369.

Mussetter Engineering Inc., 1996, "Valuation of Potential Effects of Subsidence on the Genesee River and Tributaries," Report submitted to: Akzo Nobel Salt, Inc., Clarks Summit, PA.

Nagabhushanaiah, H.S., 1967, "Meandering of Rivers," *Bulletin of the International Association of Scientific Hydrology*, Vol. 12, No. 1, pp. 28-43.

Nakagawa, T., 1983, "Boundary Effects on Stream Meandering and River Morphology," *Sedimentology*, Vol. 30, No. 1, pp. 117-127.

Nanson, G.C., 1980, "A Regional Trend to Meander Migration," *Journal Geology*, Vol. 88, p. 100-108.

Nanson G.C. and Hickin, E.J., 1983, "Channel Migration and Incision on the Beatton River," *Journal of Hydraulic Engineering*, ASCE, Vol. 109.

Nanson G.C. and Hickin, E.J., 1986, "A Statistical Analysis of Bank Erosion and Channel Migration in Western Canada," *Geological Society of America Bulletin*, Vol. 97, op, 497-504.

Neill, C.R., 1984, "Bank Erosion Versus Bedload Transport in a Gravel River," In: Elliott, C.M. (ed.), *River Meandering*, American Society of Civil Engineers, New York, p. 204-211.

Neill, C.R. and Collins, C.M., 1991, "Hydraulic/Geomorphic Relationships in a Braided to Meandering Transition, Study of Streams and Watersheds of High Hydraulic Irregularity," *Proceedings XXIV International Association for Hydraulic Research Congress*, Madrid, Spain, p. 137-147.

Nelson, J.M. and Smith, J.D., 1989, "Flow in Meandering Channels With Natural Topography," In: Ikeda, S. and Parker, G. (eds.), *River Meandering*, AGU Water Resources Monograph, 12, 69-102.

Odgaard, A.J., 1984, "Bank Erosion Contribution to Stream Sediment Load," Iowa Institute of Hydraulic Research Report No. 280, 92 p.

Odgaard, A.J., 1987, "Streambank Erosion Along Two Rivers in Iowa," *Water Resources Research*, Vol. 23, No. 7, p. 1225-1236.

Odgaard, A.J., 1989, "River-Meander Model I: Development," *Journal of Hydraulic Engineering*, ASCE, Vol. 115, No. 11, p. 1433-1450.

Odgaard, A.J., 1989, "River-Meander Model II: Applications," *Journal of Hydraulic Engineering*, ASCE, Vol. 115, No. 11, p. 1451-1464.

Odgaard, A.J. and Bergs, M.A., 1987, "Flow in Curved Erodible Channels," *IAHR Congress 1987*, p. 136-141.

Osman, A.M. and Thorne, C.R., 1988, "River Stability Analysis 1: Theory," *Journal of Hydraulic Engineering*, ASCE, Vol. 114, p. 134-150.

Page, R.W. and Nanson, G.C., 1982, "Concave Bank Benches and Associated Floodplain Formation," *Earth Surface Processes and Landforms*, Vol. 7, p. 529-542.

Paine, A.D.M., 1985, "Ergodic Reasoning in Geomorphology: A Preliminary Review," *Prog. Phys. Geogr.*, Vol. 9, p. 1-15.

Parker, G., 1983, "Meander Bends of High Amplitude," *Journal of Hydraulic Engineering*, ASCE, Vol. 109, No. 10, pp. 1323-1337.

Parker, G., Klingemena, P.C., and McClean, D.G., 1982, "Bedload and Size Distribution in Paved Gravel-bed Streams," *ASCE Journal of Hydraulics*, 108(HY4), p. 544-571.

Parker, G., Sawai, K., and Ikeda, S., 1982, "Bend Theory of River Meanders, Part 2, Nonlinear Deformation of Finite Amplitude Bends," *Journal Fluid Mechanics*, Vol. 115, p. 303-314.

Petersen, M.S., 1986, "River Engineering," Prentice-Hall, Englewood Cliffs, NJ.

Petts, G.E., Möller, H., and Roux, A.L. (eds.), 1989, "Historical Change of Large Alluvial Rivers, Western Europe," John Wiley and Sons, Chichester, UK, 355 p.

Reid, J.B., 1984, "Artificially Induced Concave Bank Deposition as a Means of Floodplain Erosion Control," In: Elliott, C.M. (ed.), *River Meandering, Proceedings of the Conference Rivers '83*, New Orleans, LA, p. 295-305.

Rhoads, B.L. and Miller, M.V., 1991, "Impact of Flow Variability on the Morphology of a Low-Energy Meandering River," *Earth Surface Processes and Landforms*, Vol. 16, No. 4, p. 357-367.

Rhodes, J. and Trent, R., 1993, "Economics of Floods, Scour, and Bridge Failures," *Hydraulic Engineering, ASCE, Proceeding of the 1993 National Conference*, Vol. 1, pp. 928-933.

Rhoads, B.L. and Welford, M.R., 1991, "Initiation of River Meandering," *Progress in Physical Geography*, Vol. 15, No. 2, p. 127-156.

Richards, K., 1982, "Rivers: Form and Process in Alluvial Channels," Methuen, London, 358 p.

Richardson, E.V., Simons, D.B., and Lagasse, P.F., 2001, "River Engineering for Highway Encroachments – Highways in the River Environment," Report FHWA NHI 01-004, Federal Highway Administration, Hydraulic Design Series No. 6, Washington, D.C.

Rinaldi, M. and Johnson, P.A., 1997, "Characterization of Stream Meanders for Stream Restoration," *Journal of Hydraulic Engineering, ASCE*, 123(6), 567-570.

Rood, S.B. and Mahoney, J.M., 1995, "River Damming and Riparian Cottonwoods Along the Marias River," *Montana, Rivers* (5), p. 195-207.

Rosgen, D.L., 1994, "A Classification of Natural Rivers," *Catena*, Vol. 22, p. 169-199.

Rosgen, D.L., 1996, "Applied River Morphology," Wildland Hydrology, 1481 Stevens Lake Road, Pagosa Springs, CO 81147, USA.

Ruhe, R.V., 1975, *Geomorphology*, Houghton Mifflin, Boston.

Schumm, S.A., 1960, "The Shape of Alluvial Channels in Relation to Sediment Type," USGS Prof. Paper 352-B, pp. 17-30.

Schumm, S.A., 1968, "River Adjustment to Altered Hydrologic Regimen - Murrumbidgee River and Paleochannels, Australia," U.S. Geological Survey Professional Paper 598, 65 p.

Schumm, S.A., 1977, "The Fluvial System," John Wiley and Sons, New York, 338 p.

Schumm, S.A., 1981, "Evolution and Response of the Fluvial System," Sedimentologic Implications: SEPM Special Publication 31, p. 19-29.

Schumm, S.A. and Kahn, H.R., 1972, "Experimental Study of Channel Patterns," *Geological Society of America Bulletin*, Vol. 83, p. 1755-1700.

Schumm, S.A. and Thorne, C.R., 1989, Geologic and Geomorphic Controls of Bank Erosion," In: Ports, M.A. (ed.), *Proceedings of the National Conference on Hydraulic Engineering*, New Orleans, LA, p. 106-111.

Schumm, S.A., Rutherford, I.D., and Brooks, J., 1994, Pre-cutoff Morphology of the Lower Mississippi River," In: Schumm, S.A., and Winkley, B.R. (eds.), *The Variability of Large Alluvial Rivers*, ASCE Press, New York, p. 13-44.

Schumm, S.A., Erskine, W.D., and Tilleard, J.W., 1996, "Morphology, Hydrology, and Evolution of the Anastomosing Ovens and King Rivers," Victoria, Australia, *Geological Society of America Bulletin*, Vol. 108, No. 10, p. 1212-1224.

Schumm, S.A., Gregory, D.I., Lattman, L.H., and Watson, C.C., 1984, "River Response to Active Tectonics," Final Report, Phase I to National Science Foundation, 124 p.

Shen, H.W., Schumm, S.A., Nelson, J.D., Doehring, D.O., and Skinner, M.M., 1983, "Methods for Assessment of Stream-Related Hazards to Highways and Bridges," FHWA/RD-80/160, Federal Highway Administration, Washington, D.C.

Sidorchuk, A. and Matveev, B., 1997, "Channel Processes and Erosion Rates in the Rivers of the Yamal Peninsula in Western Siberia," In: Olive, L.J., Loughran, R.J., and Kesby, J.A. (eds.), *Variability in Stream Erosion and Sediment Transport*, IAHS-AISH Publication 224, p. 197-202.

Simon, A., 1992, "Energy, Time and Channel Evolution in Catastrophically Disturbed Fluvial Systems," In: Philips, J.D. and Renwick, W.H. (eds.), *Geomorphic Systems, Proceedings 23rd Binghamton Symposium*, 345-373.

Simon, A. and Darby, S.E., 1997, "Process-form Interactions in Unstable Sand-bed River Channels: A Numerical Modeling Approach," *Geomorphology*, 21, 85-106.

Simon, A. and Thorne, C.R., 1996, "Channel Adjustment of an Unstable Coarse-grained Stream: Opposing Trends of Boundary and Critical Shear Stress, and the Applicability of Extremal Hypotheses," *Earth Surface Processes and Landforms*, Vol. 21, No. 2, 155-180.

Smith, D.G., 1976, "Effect of Vegetation on Lateral Migration of Anastomosed Channels of a Glacier Meltwater River," *Geological Society of America Bulletin*, Vol. 87, p. 857-860.

Smith, S.A., 1987, "Gravel Counterpoint Bars: Examples from the River Tywi, South Wales," SEPM, Spec. Publ. No. 39, F.G. Ethridge, R.M. Flores, and M.D. Harvey (eds.), p. 75-81.

Smith, S.A. and McLean, 1984, "A Model for Meandering Rivers," *Water Resources Research*, Vol. 20, p. 1301-1315.

Stølum, Hans-Henrik, 1998, "Planform Geometry and Dynamics of Meandering Rivers," *Geological Society of America Bulletin*, Vol. 110, No. 11, pp. 1485-1498.

Sun, T., Meakin, P., Jossang, T., and Schwarz, K., 1996, "A Simulation Model for Meandering Rivers," *Water Resources Research*, Vol. 32, No. 9, p. 2937-2954.

Sundborg, A., 1956, "The River Klaralven, a Study of Fluvial Processes," *Geogr. Annaler.*, Vol. 38, p 127-316.

Swanson, J.E., 1984, "Tazlina River Meanders Loop: A Case History," In: Elliott, C.M. (ed.), *River Meandering, Proceeding of the Conference Rivers '83*, New Orleans, LA, p. 231-239.

Thein, K.N., 1994, "River Plan-form Movement in an Alluvial Plain," Ph.D. Thesis – International Institute for Infrastructural, Hydraulics and Environmental Engineering, A.A. Balkema, Rotterdam, 319 p.

Thomson, J.J., 1876, "On the Windings of Rivers in Alluvial Plains," *Proceedings of the Royal Society of London*, 25, 5-8.

Thorne, C.R., 1982, "Processes and Mechanisms of River Bank Erosion," In: Hey, R.D., Bathurst, J.C., and Thorne, C.R. (eds.), *Gravel-bed Rivers*, John Wiley and Sons, New York, p. 227-71.

Thorne, C.R., 1991, "Bank Erosion and Meander Migration of the Red and Mississippi Rivers," USA, In: Van de Ven, F.H.m., Gutnecht, D., Loucks, D.P., and Satewicz, K.A. (eds.), *Hydrology for the Water Management of Large Rivers*, IAHS-AISH Pub. 201, p. 301-313.

Thorne, C.R., 1992, "Bend Scour and Bank Erosion on the Meandering Red River, Louisiana," In: P.A. Carling and G.E. Petts (eds.), *Lowland Floodplain Rivers: Geomorphological Perspectives*, John Wiley and Sons, Chichester, UK, 95-115.

Thorne, C.R., 1997, "Channel Types and Morphological Classification," Chapter 7 In: C.R. Thorne, R.D. Hey, and M.D. Newsom (eds.), *Applied Fluvial Geomorphology for River Engineering and Management*, John Wiley and Sons, Chichester, UK.

Thorne, C.R. and Lewin, J., 1979. "Bank Processes, Bed Material Movement and Planform Development in a Meandering River," In: D.D. Rhodes and G.P. Williams, (eds.), *Adjustments of the Fluvial System*, Kendall/Hunt Publishing Co, Dubuque, IA, USA, 117-137.

Thorne, C.R. and Osman, A.M., 1988, "Riverbank Stability Analysis II: Applications," *Journal Hydraulic Engineering*, ASCE, Vol. 114, p. 151-172.

Thorne, C.R. and Osman, A.M., 1988, "The Influence of Bank Stability on Regime Geometry of Natural Channels," In: White, W.R. (ed.), International Conference on River Regime, Hydraulics Research Limited, John Wiley and Sons, Chichester, UK, p. 135-147.

Thorne, C.R., Murphy, J.B., and Little, W.C., 1981, "Bank Stability and Bank Material Properties in the Bluffline Streams of Northwest Mississippi," Appendix D, Stream Channel Stability, U.S. Dept. of Agriculture, Sedimentation Laboratory, Oxford, MS, 158 p.

Thorne, C.R., Zevenbergen, L.W., Pitlick, J.C., Rais, B., Bradley, J.B., and Julien, P.Y., 1985, "Direct Measurements of Secondary Currents in a Meandering Sand-bed River," Nature, Vol. 316, No. 6022, 746-747.

Thornes, J.B. and Brunnsden, D., 1977, "Geomorphology and Time," Methuen, London.

U.S. Army Corps of Engineers (USACE) Kansas City District, 1979, "Channel Migration Investigation: Historic Channel Change Maps, Kansas River and Tributaries Bank Stabilization Component, Kansas and Osage Rivers, Kansas Study," Geomorphology Laboratory, Dept. of Geology, University of Kansas.

U.S. Army Corps of Engineers (USACE) Rock Island District, 1979, "Des Moines River Bank Erosion Study, Iowa and Missouri: Stage 2, Final Feasibility Report," Rock Island, IL.

Van der Berg, J.H., 1995, "Prediction of Alluvial Channel Pattern of Perennial Rivers," Geomorphology, Vol. 12, p. 259-279.

Vanoni, V.A. (ed.), 1975, 1977, "Sedimentation Engineering," ASCE Manuals and Reports on Engineering Practice – No. 54, Reston, VA.

Water Engineering & Technology, Inc. (WET), 1986, "Investigation of Hydrologic, Geomorphic, and Sedimentologic Characteristics of the Alabama River," U.S. Army Corps of Engineers, Mobile District, DACW01-85-D-0018, Mobile, AL.

Water Engineering & Technology, Inc. (WET), 1988, "Geomorphic Analysis of Sacramento River, Phase I Report: Geomorphic Analysis of Butte Basin Reach, River Mile 174 to River Mile 194," prepared for U.S. Army Corps of Engineers, Sacramento District, Contract No. DACW05-87-C-0094.

Water Engineering & Technology, Inc. (WET), 1990, "Geomorphic Analysis of Sacramento River, Phase II Report: Geomorphic Analysis of Reach from Colusa to Red Bluff Diversion Dam, River Mile 143 to River Mile 243," prepared for U.S. Army Corps of Engineers, Sacramento District, Contract No. DACW05-87-C-0094.

Weihaupt, J.G., 1989, "Disparities in the Forms of River Meanders and Oxbow Lakes," Water Resources Publications, Littleton, CO, 184 p.

Whitesell, B.L., Vitek, J.D., and Butler, D.R., 1988, "Changes in the Planform of the Red River," McCurtain County, Oklahoma, 1938-1984, Oklahoma Geology Notes, Vol. 48, No. 5, p. 196-211.

Whiting, P.J. and Dietrich, 1993, "Experimental Studies of Bed Topography and Flow Patterns in Large Amplitude Meanders: I. Observations," Water Resources Research, 29 (11), 3605-3614.

Whiting, P.J. and Dietrich, 1993, "Experimental Studies of Bed Topography and Flow Patterns in Large Amplitude Meanders: II. Mechanisms," Water Resources Research, 29 (11), 3615-3622.

Whitlow, J., 1984, "Dictionary of Physical Geography," Penguin, London, 591 p.

Williams, G.P., 1978, "The Case of the Shrinking Channels – the North Platte and Platte Rivers in Nebraska," United States Geological Survey Circular 781.

Williams, G.P., 1986, "River Meanders and Channel Size," *Journal of Hydrology*, 88 (1-2), pp. 147-164.

Williams, G.P. and Wolman, M.G., 1984, "Downstream Effects of Dams on Alluvial Rivers," U.S. Geological Survey Professional Paper 1286.

Wolf, P.R. and Dewitt, B.A., 2000, "Elements of Photogrammetry with Applications in GIS," Third Edition, McGraw-Hill, Boston, 608 pp.

Wolman, M.G. and Gerson, R., 1978, "Relative Scales of Time and Effectiveness of Climate in Watershed Geomorphology," *Earth Surface Proceedings*, Vol. 3, p. 189-208.

Yen, C. and Ho, S., 1990, "Bed Evolution in Channel Bends," *Journal Hydraulic Engineering*, Vol. 116, p. 544-562.

Zeller, J., 1967, "Meandering Channels in Switzerland," Symposium on river morphology, International Association Science Hydrology Publication 75, p. 174-186.

APPENDIX B

DATA BASE INDEX

NCHRP Meander Migration Project No. 24-16

Sorted by:

MODIFIED BRICE CLASSIFICATION

Stream/River Name	Site Location	State	Number of Bends	Data Source/Author	Modified Brice Class.
Canochee River	near Claxton	GA	13	J.C. Brice	A
Licking River	near Romey	KY	7	J.C. Brice	A
Mud River	near Beechland	KY	7	J.C. Brice	A
Patoka River	near Patoka	IN	10	J.C. Brice	A
Red River	at Stanton	KY	7	J.C. Brice	A
Rolling Fork River	near Boston	KY	11	J.C. Brice	A
Rough River	near Dundee	KY	6	J.C. Brice	A
Big Fork River	near Lindford	MN	17	MacDonald et al.	B1
Black Warrior River	at Tuscaloosa	AL	10	J.C. Brice	B1
Buffalo Creek	near Glencoe	MN	20	MacDonald et al.	B1
Buttahatchie River	at Caledonia	MS	15	J.C. Brice	B1
Buttahatchie River	near Sulligent	AL	20	J.C. Brice	B1
Congaree River	at Gadsden	SC	13	J.C. Brice	B1
Fishing Creek	near Enfield	NC	22	J.C. Brice	B1
Hatchie River	near Sunnyhill	TN	10	J.C. Brice	B1
Hawk Creek	near Minnesota Falls	MN	16	MacDonald et al.	B1
Little River	near Idabel	OK	6	J.C. Brice	B1
Neuse River	at Kinston	NC	10	J.C. Brice	B1
Ouachita River (II)	at Arkadelphia	AR	5	J.C. Brice	B1
Pea River	at Ariton	AL	15	J.C. Brice	B1
Pee Dee River	at PeeDee	SC	9	J.C. Brice	B1
St. Joseph River	near Newville	IN	13	J.C. Brice	B1
Sugar Creek	near Bengal	IN	7	J.C. Brice	B1
Wabash River (Ib)	at Lodi	IN	4	J.C. Brice	B1
Wabash River (IIb)	near Darwin	IN	2	J.C. Brice	B1
Wabash River (IIIa)	at St. Francisville	IN	4	J.C. Brice	B1
Wabash River (IIIb)	at St. Francisville	IN	3	J.C. Brice	B1
Yellow Creek	near Rothville	MO	15	J.C. Brice	B1
Yellow Medicine River	near Hanley Falls	MN	20	MacDonald et al.	B1
Alabama River	below Claiborne L&D	AL	17	Ayres Associates	B2
Apalachicola River (Bristol)	near Blountstown	FL	5	J.C. Brice	B2
Apalachicola River (Orange)	near Blountstown	FL	7	J.C. Brice	B2
Big Raccoon Creek	at Coxville	IN	10	J.C. Brice	B2
Choctawhatchee River (Hinsons Crossroads)	at Caryville	FL	14	J.C. Brice	B2
Des Moines River Site 5	at Eldon	IA	6	A.J. Odgaard	B2
Edisto River	near Givhans	SC	11	J.C. Brice	B2
Iowa River (I)	at Iowa City	IA	9	J.C. Brice	B2
Leaf River (II)	at Hattiesburg	MS	7	J.C. Brice	B2
Lumber River	at Fair Bluff	NC	22	J.C. Brice	B2
Neches River	at Evadale	TX	11	J.C. Brice	B2
Nowood River	near Tensleep	WY	17	S.A. Schumm	B2
Ouachita River (I)	at Arkadelphia	AR	5	J.C. Brice	B2
Pearl River	near Bogalusa	MS	18	J.C. Brice	B2
Sacramento River Site 1	at Fremont Weir	CA	4	Ayres Associates	B2
Satilla River	near Waycross	GA	11	J.C. Brice	B2
Savannah River	at Augusta	GA	14	J.C. Brice	B2
South River	near Parkersburg	NC	12	J.C. Brice	B2
White River (II)	at Petersburg	IN	6	J.C. Brice	B2
Altamaha River	at Doctortown	GA	12	J.C. Brice	C
Amite River	at Felixville	LA	8	J.C. Brice	C
Big Black River	at Bovina	MS	9	J.C. Brice	C
Big Black River	at Pickens	MS	15	J.C. Brice	C

Stream/River Name	Site Location	State	Number of Bends	Data Source/Author	Modified Brice Class.
Big Black River	at Durant	MS	13	J.C. Brice	C
Big Black River	near Big Black	MS	15	J.C. Brice	C
Brazos River	at Thompsons	TX	7	J.C. Brice	C
Brouillets Creek	near Universal	IN	22	J.C. Brice	C
Cahaba River	at Sprott	AL	7	J.C. Brice	C
Cedar River	near Conesville	IA	4	J.C. Brice	C
Chickasaw River (1)	near Kittrell	MS	7	J.C. Brice	C
Chickasaw River (2)	near Kittrell	MS	7	J.C. Brice	C
Choctawhatchee River (Caryville)	at Caryville	FL	13	J.C. Brice	C
Conecuh River	at Brewton	AL	8	J.C. Brice	C
Des Moines River Site 1	near Tracy	IA	6	A.J. Odgaard	C
Des Moines River Site 2	near Eddyville	IA	6	A.J. Odgaard	C
Des Moines River Site 4	at Ottumwa	IA	2	A.J. Odgaard	C
Des Moines River Site 6	below St. Francisville	IA	8	A.J. Odgaard	C
East Nishnibotna River	at Red Oak	IA	7	J.C. Brice	C
English River	at Kalona	IA	13	J.C. Brice	C
Genesee River	near Geneseo	NY	10	Mussetter Eng. Inc.	C
Iowa River	at Marshalltown	IA	11	J.C. Brice	C
Iowa River	near Belle Plaine	IA	12	J.C. Brice	C
Iowa River (II)	at Iowa City	IA	11	J.C. Brice	C
Kanaranzi Creek	near Ellsworth	MN	20	MacDonald et al.	C
Kansas River	at Ogden	KS	10	USACE Kansas City District	C
Kansas River	at Topeka	KS	7	USACE Kansas City District	C
Leaf River	near Bethel	MS	11	J.C. Brice	C
Leaf River (I)	at Hattiesburg	MS	8	J.C. Brice	C
Line Creek (II)	at Waugh	AL	5	J.C. Brice	C
Middle Fork Powder River	near Kaycee	WY	16	S.A. Schumm	C
Mississippi River (A and B)	at Jacobson	MN	25	MacDonald et al.	C
Nodaway River (CM Site 226)	near Burlington Jct.	MO	4	J.C. Brice	C
Ochlocknee River	near Havana	FL	10	J.C. Brice	C
Pearl River	near Columbia	MS	10	J.C. Brice	C
Powder River Site 1	near Broadus	MT	9	Martinson and Meade; Schumm	C
Powder River Site 2	near Broadus	MT	11	Martinson and Meade; Schumm	C
Powder River Site 3	near Broadus	MT	14	Martinson and Meade; Schumm	C
Powder River Site 4	near Broadus	MT	4	Martinson and Meade; Schumm	C
Powder River Site 5	near Broadus	MT	10	Martinson and Meade; Schumm	C
Powder River Site 6	near Broadus	MT	8	Martinson and Meade; Schumm	C
Republican River	at Benkelman	NE	10	S.A. Schumm	C
Republican River	at McCook	NE	6	S.A. Schumm	C
Republican River	near Orleans	NE	11	S.A. Schumm	C
Republican River	at Concordia	KS	9	S.A. Schumm	C
Root River	near Houston	MN	10	MacDonald et al.	C
Sabine River	near Merryville	LA	7	J.C. Brice	C
Sacramento River Site 2	at Colusa	CA	5	Ayres Associates	C
Sacramento River Site 6	at Hamilton City	CA	3	Ayres Associates	C
Sacramento River Site 7	near Tehama	CA	2	Ayres Associates	C
Smoky Hill River	at Junction City	KS	18	USACE Kansas City District	C
Smoky Hill River	at Abilene	KS	22	USACE Kansas City District	C

Stream/River Name	Site Location	State	Number of Bends	Data Source/Author	Modified Brice Class.
Tallahalla Creek	near Runnelstown	MS	12	J.C. Brice	C
Tombigbee River	near Amory	MS	9	J.C. Brice	C
Tongue River	near Miles City	MT	9	S.A. Schumm	C
Trinity River	at Romayor	TX	7	J.C. Brice	C
Wapsipinicon River	at DeWitt	IA	10	J.C. Brice	C
Washita River	at Anadarko	OK	3	J.C. Brice	C
Wateree River	at Camden	SC	6	J.C. Brice	C
White River (I)	at Petersburg	IN	8	J.C. Brice	C
Wild Rice River	at Twin Valley	MN	18	MacDonald et al.	C
Zumbro River	at Kellogg	MN	20	MacDonald et al.	C
Carson River	near Weeks	NV	6	Nevada DOT	D
Kansas River	at Manhattan	KS	13	USACE Kansas City District	D
Rock River	near Rock Valley	IA	17	J.C. Brice	D
Sacramento River Site 3	at Compton Landing	CA	4	Ayres Associates	D
Sacramento River Site 4	at Butte City	CA	4	Ayres Associates	D
Sacramento River Site 5	near Ordbend	CA	4	Ayres Associates	D
Apalachicola River (Rock Bluff)	near Blountstown	FL	3	J.C. Brice	E
Black River	at Poplar Bluff	MO	8	J.C. Brice	E
Cottonwood River	at Leavonworth	MN	14	MacDonald et al.	E
Des Moines River Site 3	above Chillicothe	IA	6	A.J. Odgaard	E
Fawn River	near Scott	IN	21	J.C. Brice	E
Line Creek (I)	at Waugh	AL	14	J.C. Brice	E
Little Pee Dee River	at Galivants Ferry	SC	10	J.C. Brice	E
Minnesota River (A)	at Judson	MN	13	MacDonald et al.	E
Minnesota River (B)	at Belle Plaine	MN	7	MacDonald et al.	E
Rice Creek	at Fridley	MN	20	MacDonald et al.	E
Wabash River (Ia)	at Clinton	IN	4	J.C. Brice	E
Wabash River (IIa)	near Fairbanks	IN	3	J.C. Brice	E
Wolf River	at Rossville	TN	14	J.C. Brice	E
Cimarron River	near Waynoka	OK	---	J.C. Brice	F
Cimarron River (1)	near Fairview	OK	---	J.C. Brice	F
Cimarron River (2)	near Fairview	OK	---	J.C. Brice	F
Kansas River	at Wamego	KS	8	USACE Kansas City District	F
Washita River	at Jollyville	OK	---	J.C. Brice	F
Little Missouri River	near Alzada	MT	20	S.A. Schumm	G1
Rum River	near West Point	MN	20	MacDonald et al.	G1
Saline River	at Tescott	KS	24	USACE Kansas City District	G1
Smoky Hill River	at Salina	KS	17	USACE Kansas City District	G1
Solomon River	at Solomon	KS	24	USACE Kansas City District	G1
Solomon River	at Bennington	KS	20	USACE Kansas City District	G1
Smoky Hill River	at Chapman	KS	20	USACE Kansas City District	G2
Smoky Hill River	at Solomon	KS	22	USACE Kansas City District	G2
Number of Classifications					9

NCHRP Meander Migration Project No. 24-16

Sorted by:

DATA SOURCE/AUTHOR

Stream/River Name	Site Location	State	Number of Bends	Data Source / Author	Modified Brice Class.
Des Moines River Site 1	near Tracy	IA	6	A.J. Odgaard	C
Des Moines River Site 2	near Eddyville	IA	6	A.J. Odgaard	C
Des Moines River Site 3	above Chillicothe	IA	6	A.J. Odgaard	E
Des Moines River Site 4	at Ottumwa	IA	2	A.J. Odgaard	C
Des Moines River Site 5	at Eldon	IA	6	A.J. Odgaard	B2
Des Moines River Site 6	below St. Francisville	IA	8	A.J. Odgaard	C
Alabama River	below Claiborne L&D	AL	17	Ayres Associates	B2
Sacramento River Site 1	at Fremont Weir	CA	4	Ayres Associates	B2
Sacramento River Site 2	at Colusa	CA	5	Ayres Associates	C
Sacramento River Site 3	at Compton Landing	CA	4	Ayres Associates	D
Sacramento River Site 4	at Butte City	CA	4	Ayres Associates	D
Sacramento River Site 5	near Ordbend	CA	4	Ayres Associates	D
Sacramento River Site 6	at Hamilton City	CA	3	Ayres Associates	C
Sacramento River Site 7	near Tehama	CA	2	Ayres Associates	C
Altamaha River	at Doctortown	GA	12	J.C. Brice	C
Amite River	at Felixville	LA	8	J.C. Brice	C
Apalachicola River (Bristol)	near Blountstown	FL	5	J.C. Brice	B2
Apalachicola River (Orange)	near Blountstown	FL	7	J.C. Brice	B2
Apalachicola River (Rock Bluff)	near Blountstown	FL	3	J.C. Brice	E
Big Black River	at Pickens	MS	15	J.C. Brice	C
Big Black River	at Bovina	MS	9	J.C. Brice	C
Big Black River	at Durant	MS	13	J.C. Brice	C
Big Black River	near Big Black	MS	15	J.C. Brice	C
Big Raccoon Creek	at Coxville	IN	10	J.C. Brice	B2
Black River	at Poplar Bluff	MO	8	J.C. Brice	E
Black Warrior River	at Tuscaloosa	AL	10	J.C. Brice	B1
Brazos River	at Thompsons	TX	7	J.C. Brice	C
Brouillets Creek	near Universal	IN	22	J.C. Brice	C
Buttahatchie River	at Caledonia	MS	15	J.C. Brice	B1
Buttahatchie River	near Sulligent	AL	20	J.C. Brice	B1
Cahaba River	at Sprott	AL	7	J.C. Brice	C
Canoochee River	near Claxton	GA	13	J.C. Brice	A
Cedar River	near Conesville	IA	4	J.C. Brice	C
Chickasaw River (1)	near Kittrell	MS	7	J.C. Brice	C
Chickasaw River (2)	near Kittrell	MS	7	J.C. Brice	C
Choctawhatchee River (Caryville)	at Caryville	FL	13	J.C. Brice	C
Choctawhatchee River (Hinsons Crossroads)	at Caryville	FL	14	J.C. Brice	B2
Cimarron River	near Waynoka	OK	---	J.C. Brice	F
Cimarron River (1)	near Fairview	OK	---	J.C. Brice	F
Cimarron River (2)	near Fairview	OK	---	J.C. Brice	F
Conecuh River	at Brewton	AL	8	J.C. Brice	C
Congaree River	at Gadsden	SC	13	J.C. Brice	B1
East Nishnibotna River	at Red Oak	IA	7	J.C. Brice	C
Edisto River	near Givhans	SC	11	J.C. Brice	B2
English River	at Kalona	IA	13	J.C. Brice	C
Fawn River	near Scott	IN	21	J.C. Brice	E
Fishing Creek	near Enfield	NC	22	J.C. Brice	B1

Stream/River Name	Site Location	State	Number of Bends	Data Source / Author	Modified Brice Class.
Iowa River	at Marshalltown	IA	11	J.C. Brice	C
Iowa River	near Belle Plaine	IA	12	J.C. Brice	C
Iowa River (I)	at Iowa City	IA	9	J.C. Brice	B2
Iowa River (II)	at Iowa City	IA	11	J.C. Brice	C
Leaf River	near Bethel	MS	11	J.C. Brice	C
Leaf River (I)	at Hattiesburg	MS	8	J.C. Brice	C
Leaf River (II)	at Hattiesburg	MS	7	J.C. Brice	B2
Licking River	near Romey	KY	7	J.C. Brice	A
Line Creek (I)	at Waugh	AL	14	J.C. Brice	E
Line Creek (II)	at Waugh	AL	5	J.C. Brice	C
Little Pee Dee River	at Galivants Ferry	SC	10	J.C. Brice	E
Little River	near Idabel	OK	6	J.C. Brice	B1
Lumber River	at Fair Bluff	NC	22	J.C. Brice	B2
Mud River	near Beechland	KY	7	J.C. Brice	A
Neches River	at Evadale	TX	11	J.C. Brice	B2
Neuse River	at Kinston	NC	10	J.C. Brice	B1
Nodaway River (CM Site 226)	near Burlington Jct.	MO	4	J.C. Brice	C
Ochlocknee River	near Havana	FL	10	J.C. Brice	C
Ouachita River (II)	at Arkadelphia	AR	5	J.C. Brice	B1
Ouachita River (I)	at Arkadelphia	AR	5	J.C. Brice	B2
Patoka River	near Patoka	IN	10	J.C. Brice	A
Pea River	at Ariton	AL	15	J.C. Brice	B1
Pearl River	near Bogalusa	MS	18	J.C. Brice	B2
Pearl River	near Columbia	MS	10	J.C. Brice	C
Pee Dee River	at PeeDee	SC	9	J.C. Brice	B1
Red River	at Stanton	KY	7	J.C. Brice	A
Rock River	near Rock Valley	IA	17	J.C. Brice	D
Rolling Fork River	near Boston	KY	11	J.C. Brice	A
Rough River	near Dundee	KY	6	J.C. Brice	A
Sabine River	near Merryville	LA	7	J.C. Brice	C
Satilla River	near Waycross	GA	11	J.C. Brice	B2
Savannah River	at Augusta	GA	14	J.C. Brice	B2
St. Joseph River	near Newville	IN	13	J.C. Brice	B1
South River	near Parkersburg	NC	12	J.C. Brice	B2
Sugar Creek	near Bengal	IN	7	J.C. Brice	B1
Tallahalla Creek	near Runnelstown	MS	12	J.C. Brice	C
Tombigbee River	near Amory	MS	9	J.C. Brice	C
Trinity River	at Romayor	TX	7	J.C. Brice	C
Wabash River (Ia)	at Clinton	IN	4	J.C. Brice	E
Wabash River (Ib)	at Lodi	IN	4	J.C. Brice	B1
Wabash River (IIa)	near Fairbanks	IN	3	J.C. Brice	E
Wabash River (IIb)	near Darwin	IN	2	J.C. Brice	B1
Wabash River (IIIa)	at St. Francisville	IN	4	J.C. Brice	B1
Wabash River (IIIb)	at St. Francisville	IN	3	J.C. Brice	B1
Wapsipinicon River	at DeWitt	IA	10	J.C. Brice	C
Washita River	at Jollyville	OK	---	J.C. Brice	F
Washita River	at Anadarko	OK	3	J.C. Brice	C
Wateree River	at Camden	SC	6	J.C. Brice	C
White River (I)	at Petersburg	IN	8	J.C. Brice	C
White River (II)	at Petersburg	IN	6	J.C. Brice	B2
Wolf River	at Rossville	TN	14	J.C. Brice	E
Yellow Creek	near Rothville	MO	15	J.C. Brice	B1
Big Fork River	near Lindford	MN	17	MacDonald et al.	B1
Buffalo Creek	near Glencoe	MN	20	MacDonald et al.	B1
Cottonwood River	at Leavonworth	MN	14	MacDonald et al.	E
Hawk Creek	near Minnesota Falls	MN	16	MacDonald et al.	B1
Kanaranzi Creek	near Ellsworth	MN	20	MacDonald et al.	C

Stream/River Name	Site Location	State	Number of Bends	Data Source / Author	Modified Brice Class.
Mississippi River (A and B)	at Jacobson	MN	25	MacDonald et al.	C
Rice Creek	at Fridley	MN	20	MacDonald et al.	E
Root River	near Houston	MN	10	MacDonald et al.	C
Rum River	near West Point	MN	20	MacDonald et al.	G1
Wild Rice River	at Twin Valley	MN	18	MacDonald et al.	C
Yellow Medicine River	near Hanley Falls	MN	20	MacDonald et al.	B1
Zumbro River	at Kellogg	MN	20	MacDonald et al.	C
Powder River Site 1	near Broadus	MT	9	Martinson and Meade; Schumm	C
Powder River Site 2	near Broadus	MT	11	Martinson and Meade; Schumm	C
Powder River Site 3	near Broadus	MT	14	Martinson and Meade; Schumm	C
Powder River Site 4	near Broadus	MT	4	Martinson and Meade; Schumm	C
Powder River Site 5	near Broadus	MT	10	Martinson and Meade; Schumm	C
Powder River Site 6	near Broadus	MT	8	Martinson and Meade; Schumm	C
Genesee River	near Geneseo	NY	10	Mussetter Eng. Inc	C
Carson River	near Weeks	NV	6	Nevada DOT	D
Little Missouri River	near Alzada	MT	20	S.A. Schumm	G1
Middle Fork Powder River	near Kaycee	WY	16	S.A. Schumm	C
Nowood River	near Tensleep	WY	17	S.A. Schumm	B2
Republican River	at Benkelman	NE	10	S.A. Schumm	C
Republican River	at McCook	NE	6	S.A. Schumm	C
Republican River	near Orleans	NE	11	S.A. Schumm	C
Republican River	at Concordia	KS	9	S.A. Schumm	C
Tongue River	near Miles City	MT	9	S.A. Schumm	C
Kansas River	at Topeka	KS	7	USACE Kansas City District	C
Kansas River	at Wamego	KS	8	USACE Kansas City District	F
Kansas River	at Manhattan	KS	13	USACE Kansas City District	D
Kansas River	at Ogden	KS	10	USACE Kansas City District	C
Saline River	at Tescott	KS	24	USACE Kansas City District	G1
Smoky Hill River	at Junction City	KS	18	USACE Kansas City District	C
Smoky Hill River	at Chapman	KS	20	USACE Kansas City District	G2
Smoky Hill River	at Abilene	KS	22	USACE Kansas City District	C
Smoky Hill River	at Solomon	KS	22	USACE Kansas City District	G2
Smoky Hill River	at Salina	KS	17	USACE Kansas City District	G1
Solomon River	at Solomon	KS	24	USACE Kansas City District	G1
Solomon River	at Bennington	KS	20	USACE Kansas City District	G1
Number of Sources/Authors				9	

NCHRP Meander Migration Project No. 24-16

Sorted by:

RIVER NAME

Stream/River Name	Site Location	State	Number of Bends	Data Source/Author	Modified Brice Classification
Alabama River	below Claiborne L&D	AL	17	Ayres Associates	B2
Altamaha River	at Doctortown	GA	12	J.C. Brice	C
Amite River	at Felixville	LA	8	J.C. Brice	C
Apalachicola River (Bristol)	near Blountstown	FL	5	J.C. Brice	B2
Apalachicola River (Orange)	near Blountstown	FL	7	J.C. Brice	B2
Apalachicola River (Rock Bluff)	near Blountstown	FL	3	J.C. Brice	E
Big Black River	at Pickens	MS	15	J.C. Brice	C
Big Black River	at Bovina	MS	9	J.C. Brice	C
Big Black River	at Durant	MS	13	J.C. Brice	C
Big Black River	near Big Black	MS	15	J.C. Brice	C
Big Fork River	near Lindford	MN	17	MacDonald et al.	B1
Big Raccoon Creek	at Coxville	IN	10	J.C. Brice	B2
Black River	at Poplar Bluff	MO	8	J.C. Brice	E
Black Warrior River	at Tuscaloosa	AL	10	J.C. Brice	B1
Brazos River	at Thompsons	TX	7	J.C. Brice	C
Brouillets Creek	near Universal	IN	22	J.C. Brice	C
Buffalo Creek	near Glencoe	MN	20	MacDonald et al.	B1
Buttahatchie River	at Caledonia	MS	15	J.C. Brice	B1
Buttahatchie River	near Sulligent	AL	20	J.C. Brice	B1
Cahaba River	at Sprott	AL	7	J.C. Brice	C
Canoochee River	near Claxton	GA	13	J.C. Brice	A
Carson River	near Weeks	NV	6	Nevada DOT	D
Cedar River	near Conesville	IA	4	J.C. Brice	C
Chickasaw River (1)	near Kittrell	MS	7	J.C. Brice	C
Chickasaw River (2)	near Kittrell	MS	7	J.C. Brice	C
Choctawhatchee River (Caryville)	at Caryville	FL	13	J.C. Brice	C
Choctawhatchee River (Hinsons Crossroads)	at Caryville	FL	14	J.C. Brice	B2
Cimarron River	near Waynoka	OK	---	J.C. Brice	F
Cimarron River (1)	near Fairview	OK	---	J.C. Brice	F
Cimarron River (2)	near Fairview	OK	---	J.C. Brice	F
Conecuh River	at Brewton	AL	8	J.C. Brice	C
Congaree River	at Gadsden	SC	13	J.C. Brice	B1
Cottonwood River	at Leavonworth	MN	14	MacDonald et al.	E
Des Moines River Site 1	near Tracy	IA	6	A.J. Odgaard	C
Des Moines River Site 2	near Eddyville	IA	6	A.J. Odgaard	C
Des Moines River Site 3	above Chillicothe	IA	6	A.J. Odgaard	E
Des Moines River Site 4	at Ottumwa	IA	2	A.J. Odgaard	C
Des Moines River Site 5	at Eldon	IA	6	A.J. Odgaard	B2
Des Moines River Site 6	below St. Francisville	IA	8	A.J. Odgaard	C
East Nishnibotna River	at Red Oak	IA	7	J.C. Brice	C
Edisto River	near Givhans	SC	11	J.C. Brice	B2
English River	at Kalona	IA	13	J.C. Brice	C
Fawn River	near Scott	IN	21	J.C. Brice	E
Fishing Creek	near Enfield	NC	22	J.C. Brice	B1
Genesee River	near Geneseo	NY	10	Mussetter Eng. Inc.	C
Hatchie River	near Sunnyhill	TN	10	J.C. Brice	B1
Hawk Creek	near Minnesota Falls	MN	16	MacDonald et al.	B1
Iowa River	at Marshalltown	IA	11	J.C. Brice	C
Iowa River	near Belle Plaine	IA	12	J.C. Brice	C
Iowa River (I)	at Iowa City	IA	9	J.C. Brice	B2
Iowa River (II)	at Iowa City	IA	11	J.C. Brice	C

Stream/River Name	Site Location	State	Number of Bends	Data Source/Author	Modified Brice Classification
Kanaranzi Creek	near Ellsworth	MN	20	MacDonald et al.	C
Kansas River	at Topeka	KS	7	USACE Kansas City District	C
Kansas River	at Wamego	KS	8	USACE Kansas City District	F
Kansas River	at Manhattan	KS	13	USACE Kansas City District	D
Kansas River	at Ogden	KS	10	USACE Kansas City District	C
Leaf River	near Bethel	MS	11	J.C. Brice	C
Leaf River (I)	at Hattiesburg	MS	8	J.C. Brice	C
Leaf River (II)	at Hattiesburg	MS	7	J.C. Brice	B2
Licking River	near Romey	KY	7	J.C. Brice	A
Line Creek (I)	at Waugh	AL	14	J.C. Brice	E
Line Creek (II)	at Waugh	AL	5	J.C. Brice	C
Little Missouri River	near Alzada	MT	20	S.A. Schumm	G1
Little Pee Dee River	at Galivants Ferry	SC	10	J.C. Brice	E
Little River	near Idabel	OK	6	J.C. Brice	B1
Lumber River	at Fair Bluff	NC	22	J.C. Brice	B2
Middle Fork Powder River	near Kaycee	WY	16	S.A. Schumm	C
Minnesota River (A)	at Judson	MN	13	MacDonald et al.	E
Minnesota River (B)	at Belle Plaine	MN	7	MacDonald et al.	E
Mississippi River (A and B)	at Jacobson	MN	25	MacDonald et al.	C
Mud River	near Beechland	KY	7	J.C. Brice	A
Neches River	at Evadale	TX	11	J.C. Brice	B2
Neuse River	at Kinston	NC	10	J.C. Brice	B1
Nodaway River (CM Site 226)	near Burlington Jct.	MO	4	J.C. Brice	C
Nowood River	near Tensleep	WY	17	S.A. Schumm	B2
Ochlocknee River	near Havana	FL	10	J.C. Brice	C
Ouachita River (II)	at Arkadelphia	AR	5	J.C. Brice	B1
Ouachita River (I)	at Arkadelphia	AR	5	J.C. Brice	B2
Patoka River	near Patoka	IN	10	J.C. Brice	A
Pea River	at Ariton	AL	15	J.C. Brice	B1
Pearl River	near Bogalusa	MS	18	J.C. Brice	B2
Pearl River	near Columbia	MS	10	J.C. Brice	C
Pee Dee River	at PeeDee	SC	9	J.C. Brice	B1
Powder River Site 1	near Broadus	MT	9	Martinson and Meade; Schumm	C
Powder River Site 2	near Broadus	MT	11	Martinson and Meade; Schumm	C
Powder River Site 3	near Broadus	MT	14	Martinson and Meade; Schumm	C
Powder River Site 4	near Broadus	MT	4	Martinson and Meade; Schumm	C
Powder River Site 5	near Broadus	MT	10	Martinson and Meade; Schumm	C
Powder River Site 6	near Broadus	MT	8	Martinson and Meade; Schumm	C
Red River	at Stanton	KY	7	J.C. Brice	A
Republican River	at Benkelman	NE	10	S.A. Schumm	C
Republican River	at McCook	NE	6	S.A. Schumm	C
Republican River	near Orleans	NE	11	S.A. Schumm	C
Republican River	at Concordia	KS	9	S.A. Schumm	C
Rice Creek	at Fridley	MN	20	MacDonald et al.	E
Rock River	near Rock Valley	IA	17	J.C. Brice	D
Rolling Fork River	near Boston	KY	11	J.C. Brice	A
Root River	near Houston	MN	10	MacDonald et al.	C

Stream/River Name	Site Location	State	Number of Bends	Data Source/Author	Modified Brice Classification
Rough River	near Dundee	KY	6	J.C. Brice	A
Rum River	near West Point	MN	20	MacDonald et al.	G1
Sabine River	near Merryville	LA	7	J.C. Brice	C
Sacramento River Site 1	at Fremont Weir	CA	4	Ayres Associates	B2
Sacramento River Site 2	at Colusa	CA	5	Ayres Associates	C
Sacramento River Site 3	at Compton Landing	CA	4	Ayres Associates	D
Sacramento River Site 4	at Butte City	CA	4	Ayres Associates	D
Sacramento River Site 5	near Ordbend	CA	4	Ayres Associates	D
Sacramento River Site 6	at Hamilton City	CA	3	Ayres Associates	C
Sacramento River Site 7	near Tehama	CA	2	Ayres Associates	C
Saline River	at Tescott	KS	24	USACE Kansas City District	G1
Satilla River	near Waycross	GA	11	J.C. Brice	B2
Savannah River	at Augusta	GA	14	J.C. Brice	B2
Smoky Hill River	at Junction City	KS	18	USACE Kansas City District	C
Smoky Hill River	at Chapman	KS	20	USACE Kansas City District	G2
Smoky Hill River	at Abilene	KS	22	USACE Kansas City District	C
Smoky Hill River	at Solomon	KS	22	USACE Kansas City District	G2
Smoky Hill River	at Salina	KS	17	USACE Kansas City District	G1
South River	near Parkersburg	NC	12	J.C. Brice	B2
Solomon River	at Solomon	KS	24	USACE Kansas City District	G1
Solomon River	at Bennington	KS	20	USACE Kansas City District	G1
St. Joseph River	near Newville	IN	13	J.C. Brice	B1
Sugar Creek	near Bengal	IN	7	J.C. Brice	B1
Tallahalla Creek	near Runnelstown	MS	12	J.C. Brice	C
Tombigbee River	near Amory	MS	9	J.C. Brice	C
Tongue River	near Miles City	MT	9	S.A. Schumm	C
Trinity River	at Romayor	TX	7	J.C. Brice	C
Wabash River (Ia)	at Clinton	IN	4	J.C. Brice	E
Wabash River (Ib)	at Lodi	IN	4	J.C. Brice	B1
Wabash River (IIa)	near Fairbanks	IN	3	J.C. Brice	E
Wabash River (IIb)	near Darwin	IN	2	J.C. Brice	B1
Wabash River (IIIa)	at St. Francisville	IN	4	J.C. Brice	B1
Wabash River (IIIb)	at St. Francisville	IN	3	J.C. Brice	B1
Wapsipinicon River	at DeWitt	IA	10	J.C. Brice	C
Washita River	at Jollyville	OK	---	J.C. Brice	F
Washita River	at Anadarko	OK	3	J.C. Brice	C
Wateree River	at Camden	SC	6	J.C. Brice	C
White River (I)	at Petersburg	IN	8	J.C. Brice	C
White River (II)	at Petersburg	IN	6	J.C. Brice	B2
Wild Rice River	at Twin Valley	MN	18	MacDonald et al.	C
Wolf River	at Rossville	TN	14	J.C. Brice	E
Yellow Creek	near Rothville	MO	15	J.C. Brice	B1
Yellow Medicine River	near Hanley Falls	MN	20	MacDonald et al.	B1
Zumbro River	at Kellogg	MN	20	MacDonald et al.	C
Number of Sites = 141	Number of Bends = 1503				

NCHRP Meander Migration Project No. 24-16

Sorted by:

STATE

Stream/River Name	Site Location	State	Number of Bends	Data Source/Author	Modified Brice Classification
Alabama River	below Claiborne L&D	AL	17	Ayres Associates	B2
Black Warrior River	at Tuscaloosa	AL	10	J.C. Brice	B1
Buttahatchie River	near Sulligent	AL	20	J.C. Brice	B1
Cahaba River	at Sprott	AL	7	J.C. Brice	C
Conecuh River	at Brewton	AL	8	J.C. Brice	C
Line Creek (I)	at Waugh	AL	14	J.C. Brice	E
Line Creek (II)	at Waugh	AL	5	J.C. Brice	C
Pea River	at Ariton	AL	15	J.C. Brice	B1
Ouachita River (II)	at Arkadelphia	AR	5	J.C. Brice	B1
Ouachita River (I)	at Arkadelphia	AR	5	J.C. Brice	B2
Sacramento River Site 1	at Fremont Weir	CA	4	Ayres Associates	B2
Sacramento River Site 2	at Colusa	CA	5	Ayres Associates	C
Sacramento River Site 3	at Compton Landing	CA	4	Ayres Associates	D
Sacramento River Site 4	at Butte City	CA	4	Ayres Associates	D
Sacramento River Site 5	near Ordbend	CA	4	Ayres Associates	D
Sacramento River Site 6	at Hamilton City	CA	3	Ayres Associates	C
Sacramento River Site 7	near Tehama	CA	2	Ayres Associates	C
Apalachicola River (Bristol)	near Blountstown	FL	5	J.C. Brice	B2
Apalachicola River (Orange)	near Blountstown	FL	7	J.C. Brice	B2
Apalachicola River (Rock Bluff)	near Blountstown	FL	3	J.C. Brice	E
Choctawhatchee River (Caryville)	at Caryville	FL	13	J.C. Brice	C
Choctawhatchee River (Hinsons Crossroads)	at Caryville	FL	14	J.C. Brice	B2
Ochlocknee River	near Havana	FL	10	J.C. Brice	C
Altamaha River	at Doctortown	GA	12	J.C. Brice	C
Canoochee River	near Claxton	GA	13	J.C. Brice	A
Satilla River	near Waycross	GA	11	J.C. Brice	B2
Savannah River	at Augusta	GA	14	J.C. Brice	B2
Cedar River	near Conesville	IA	4	J.C. Brice	C
Des Moines River Site 1	near Tracy	IA	6	A.J. Odgaard	C
Des Moines River Site 2	near Eddyville	IA	6	A.J. Odgaard	C
Des Moines River Site 3	above Chillicothe	IA	6	A.J. Odgaard	E
Des Moines River Site 4	at Ottumwa	IA	2	A.J. Odgaard	C
Des Moines River Site 5	at Eldon	IA	6	A.J. Odgaard	B2
Des Moines River Site 6	below St. Francisville	IA	8	A.J. Odgaard	C
East Nishnibotna River	at Red Oak	IA	7	J.C. Brice	C
English River	at Kalona	IA	13	J.C. Brice	C
Iowa River	at Marshalltown	IA	11	J.C. Brice	C
Iowa River	near Belle Plaine	IA	12	J.C. Brice	C
Iowa River (I)	at Iowa City	IA	9	J.C. Brice	B2
Iowa River (II)	at Iowa City	IA	11	J.C. Brice	C
Rock River	near Rock Valley	IA	17	J.C. Brice	D
Wapsipinicon River	at DeWitt	IA	10	J.C. Brice	C
Big Raccoon Creek	at Coxville	IN	10	J.C. Brice	B2
Brouillets Creek	near Universal	IN	22	J.C. Brice	C
Fawn River	near Scott	IN	21	J.C. Brice	E
Patoka River	near Patoka	IN	10	J.C. Brice	A
St. Joseph River	near Newville	IN	13	J.C. Brice	B1
Sugar Creek	near Bengal	IN	7	J.C. Brice	B1
Wabash River (Ia)	at Clinton	IN	4	J.C. Brice	E
Wabash River (Ib)	at Lodi	IN	4	J.C. Brice	B1

Stream/River Name	Site Location	State	Number of Bends	Data Source/Author	Modified Brice Classification
Wabash River (IIa)	near Fairbanks	IN	3	J.C. Brice	E
Wabash River (IIb)	near Darwin	IN	2	J.C. Brice	B1
Wabash River (IIIa)	at St. Francisville	IN	4	J.C. Brice	B1
Wabash River (IIIb)	at St. Francisville	IN	3	J.C. Brice	B1
White River (I)	at Petersburg	IN	8	J.C. Brice	C
White River (II)	at Petersburg	IN	6	J.C. Brice	B2
Kansas River	at Topeka	KS	7	USACE Kansas City District	C
Kansas River	at Wamego	KS	8	USACE Kansas City District	F
Kansas River	at Manhattan	KS	13	USACE Kansas City District	D
Kansas River	at Ogden	KS	10	USACE Kansas City District	C
Republican River	at Concordia	KS	9	S.A. Schumm	C
Saline River	at Tescott	KS	24	USACE Kansas City District	G1
Smoky Hill River	at Junction City	KS	18	USACE Kansas City District	C
Smoky Hill River	at Chapman	KS	20	USACE Kansas City District	G2
Smoky Hill River	at Abilene	KS	22	USACE Kansas City District	C
Smoky Hill River	at Solomon	KS	22	USACE Kansas City District	G2
Smoky Hill River	at Salina	KS	17	USACE Kansas City District	G1
Solomon River	at Solomon	KS	24	USACE Kansas City District	G1
Solomon River	at Bennington	KS	20	USACE Kansas City District	G1
Licking River	near Romey	KY	7	J.C. Brice	A
Mud River	near Beechland	KY	7	J.C. Brice	A
Red River	at Stanton	KY	7	J.C. Brice	A
Rolling Fork River	near Boston	KY	11	J.C. Brice	A
Rough River	near Dundee	KY	6	J.C. Brice	A
Amite River	at Felixville	LA	8	J.C. Brice	C
Sabine River	near Merryville	LA	7	J.C. Brice	C
Big Fork River	near Lindford	MN	17	MacDonald et al.	B1
Buffalo Creek	near Glencoe	MN	20	MacDonald et al.	B1
Cottonwood River	at Leavonworth	MN	14	MacDonald et al.	E
Hawk Creek	near Minnesota Falls	MN	16	MacDonald et al.	B1
Kanaranzi Creek	near Ellsworth	MN	20	MacDonald et al.	C
Minnesota River (A)	at Judson	MN	13	MacDonald et al.	E
Minnesota River (B)	at Belle Plaine	MN	7	MacDonald et al.	E
Mississippi River (A and B)	at Jacobson	MN	25	MacDonald et al.	C
Rice Creek	at Fridley	MN	20	MacDonald et al.	E
Root River	near Houston	MN	10	MacDonald et al.	C
Rum River	near West Point	MN	20	MacDonald et al.	G1
Wild Rice River	at Twin Valley	MN	18	MacDonald et al.	C
Yellow Medicine River	near Hanley Falls	MN	20	MacDonald et al.	B1
Zumbro River	at Kellogg	MN	20	MacDonald et al.	C
Black River	at Poplar Bluff	MO	8	J.C. Brice	E
Nodaway River (CM Site 226)	near Burlington Jct.	MO	4	J.C. Brice	C
Yellow Creek	near Rothville	MO	15	J.C. Brice	B1
Big Black River	at Pickens	MS	15	J.C. Brice	C
Big Black River	at Bovina	MS	9	J.C. Brice	C

Stream/River Name	Site Location	State	Number of Bends	Data Source/Author	Modified Brice Classification
Big Black River	at Durant	MS	13	J.C. Brice	C
Big Black River	near Big Black	MS	15	J.C. Brice	C
Buttahatchie River	at Caledonia	MS	15	J.C. Brice	B1
Chickasaway River (1)	near Kittrell	MS	7	J.C. Brice	C
Chickasaway River (2)	near Kittrell	MS	7	J.C. Brice	C
Leaf River	near Bethel	MS	11	J.C. Brice	C
Leaf River (I)	at Hattiesburg	MS	8	J.C. Brice	C
Leaf River (II)	at Hattiesburg	MS	7	J.C. Brice	B2
Pearl River	near Bogalusa	MS	18	J.C. Brice	B2
Pearl River	near Columbia	MS	10	J.C. Brice	C
Tallahalla Creek	near Runnelstown	MS	12	J.C. Brice	C
Tombigbee River	near Amory	MS	9	J.C. Brice	C
Little Missouri River	near Alzada	MT	20	S.A. Schumm	G1
Powder River Site 1	near Broadus	MT	9	Martinson and Meade; Schumm	C
Powder River Site 2	near Broadus	MT	11	Martinson and Meade; Schumm	C
Powder River Site 3	near Broadus	MT	14	Martinson and Meade; Schumm	C
Powder River Site 4	near Broadus	MT	4	Martinson and Meade; Schumm	C
Powder River Site 5	near Broadus	MT	10	Martinson and Meade; Schumm	C
Powder River Site 6	near Broadus	MT	8	Martinson and Meade; Schumm	C
Tongue River	near Miles City	MT	9	S.A. Schumm	C
Fishing Creek	near Enfield	NC	22	J.C. Brice	B1
Lumber River	at Fair Bluff	NC	22	J.C. Brice	B2
Neuse River	at Kinston	NC	10	J.C. Brice	B1
South River	near Parkersburg	NC	12	J.C. Brice	B2
Republican River	at Benkelman	NE	10	S.A. Schumm	C
Republican River	at McCook	NE	6	S.A. Schumm	C
Republican River	near Orleans	NE	11	S.A. Schumm	C
Carson River	near Weeks	NV	6	Nevada DOT	D
Genesee River	near Geneseo	NY	10	Mussetter Eng. Inc.	C
Cimarron River	near Waynoka	OK	---	J.C. Brice	F
Cimarron River (1)	near Fairview	OK	---	J.C. Brice	F
Cimarron River (2)	near Fairview	OK	---	J.C. Brice	F
Little River	near Idabel	OK	6	J.C. Brice	B1
Washita River	at Jollyville	OK	---	J.C. Brice	F
Washita River	at Anadarko	OK	3	J.C. Brice	C
Congaree River	at Gadsden	SC	13	J.C. Brice	B1
Edisto River	near Givhans	SC	11	J.C. Brice	B2
Little Pee Dee River	at Galivants Ferry	SC	10	J.C. Brice	E
Pee Dee River	at PeeDee	SC	9	J.C. Brice	B1
Wateree River	at Camden	SC	6	J.C. Brice	C
Hatchie River	near Sunnyhill	TN	10	J.C. Brice	B1
Wolf River	at Rossville	TN	14	J.C. Brice	E
Brazos River	at Thompsons	TX	7	J.C. Brice	C
Neches River	at Evadale	TX	11	J.C. Brice	B2
Trinity River	at Romayor	TX	7	J.C. Brice	C
Middle Fork Powder River	near Kaycee	WY	16	S.A. Schumm	C
Nowood River	near Tensleep	WY	17	S.A. Schumm	B2
Number of States			23		

APPENDIX C

BETA TESTING RESULTS

Table C1. Simple Overlay: Sacramento River Site

BEND 1							
Evaluator	Radius of Curvature (ft)			Migration Distance (ft)		2028 Predicted Radius of Curvature (ft)	2028 Predicted Migration Distance (ft)
	1937	1972	1998	1937-72	1972-98		
Univ. of Nottingham	560	1900	1800	1640	920	1700	1060
Ayres Associates	900	2300	1600	3225	1545	793	1782
Mussetter Eng. Inc.	1130	1250	1350	460	1470	1423	1656
Alabama DOT	880	1800	1900	4280	1300	2022	1500
Alaska DOT	NC	NC	NC	NC	NC	NC	NC
California DOT	960	2200	1500	2260	1600	692	1846
Georgia DOT	NC	NC	NC	NC	NC	NC	NC
Maryland DOT	1124	1772	1052	1891	1357	559	1566
Nevada DOT	NC	NC	NC	NC	NC	NC	NC
Wyoming DOT	1120	2080	1760	2640	1140	1459	1267
City of Austin, TX	NC	NC	NC	NC	NC	NC	NC
Author	600	2000	1500	2790	1290	923	1490
Mean	909	1913	1558	2398	1328	1196	1521
Standard Deviation	226.9	325	274	1137	222	528	260
BEND 2							
Evaluator	Radius of Curvature (ft)			Migration Distance (ft)		2028 Predicted Radius of Curvature (ft)	2028 Predicted Migration Distance (ft)
	1937	1972	1998	1937-72	1972-98		
Univ. of Nottingham	3000	1600	1500	2380	1250	1384	1430
Ayres Associates	3000	1400	1400	2830	1260	1400	1455
Mussetter Eng. Inc.	2150	1460	1390	2400	1460	1311	1644
Alabama DOT	1500	1420	1540	2000	1360	1690	1570
Alaska DOT	NC	NC	NC	NC	NC	NC	NC
California DOT	2400	1300	1240	2400	1140	1170	1315
Georgia DOT	NC	NC	NC	NC	NC	NC	NC
Maryland DOT	1328	1056	1064	1662	904	1073	1043
Nevada DOT	1520	2320	1640	2480	1520	855	1754
Wyoming DOT	2160	1420	1600	2480	1160	1825	1289
City of Austin, TX	NC	NC	NC	NC	NC	NC	NC
Author	1800	1500	1650	2150	1130	1823	1304
Mean	2095	1497	1447	2309	1243	1392	1423
Standard Deviation	622	343	196	334	188	337	215

Table C2. ARCVIEW: Sacramento River Site

BEND 1							
Evaluator	Radius of Curvature (ft)			Migration Distance (ft)		2028 Predicted Radius of Curvature (ft)	2028 Predicted Migration Distance (ft)
	1937	1972	1998	1937-72	1972-98		
Univ. of Nottingham	NC	NC	NC	NC	NC	NC	NC
Ayres Associates	1087	1974	1771	1920	1653	1593	1459
Mussetter Eng. Inc.	1604	1995	1917	2224	1534	1848	1353
Alabama DOT	1608	3052	2627	2423	1568	2144	1809
Alaska DOT	NC	NC	NC	NC	NC	NC	NC
California DOT	1584	2332	1811	2000	2011	1210	2319
Georgia DOT	NC	NC	NC	NC	NC	NC	NC
Maryland DOT	NC	NC	NC	NC	NC	NC	NC
Nevada DOT	NC	NC	NC	NC	NC	NC	NC
Wyoming DOT	799	1748	1585	4004	1037	1396	1196
City of Austin, TX	NC	NC	NC	NC	NC	NC	NC
Author	1328	1876	1549	2077	1812	1172	2091
Mean	1335	2163	1877	2441	1603	1560	1705
Standard Deviation	334	477	393	786	328	381	443
BEND 2							
Evaluator	Radius of Curvature (ft)			Migration Distance (ft)		2028 Predicted Radius of Curvature (ft)	2028 Predicted Migration Distance (ft)
	1937	1972	1998	1937-72	1972-98		
Univ. of Nottingham	NC	NC	NC	NC	NC	NC	NC
Ayres Associates	2096	1499	1529	1781	1801	1556	1589
Mussetter Eng. Inc.	2594	1588	1513	2004	1920	1446	1694
Alabama DOT	2608	1859	1493	2482	1758	1072	2028
Alaska DOT	NC	NC	NC	NC	NC	NC	NC
California DOT	2975	1488	1427	2304	1899	1357	2190
Georgia DOT	NC	NC	NC	NC	NC	NC	NC
Maryland DOT	NC	NC	NC	NC	NC	NC	NC
Nevada DOT	NC	NC	NC	NC	NC	NC	NC
Wyoming DOT	1996	1465	1539	2441	1893	1623	1623
City of Austin, TX	NC	NC	NC	NC	NC	NC	NC
Author	2698	1475	1425	1800	1971	1367	2274
Mean	2494	1562	1488	2135	1874	1404	1900
Standard Deviation	375	152	50	315	79	193	302

Table C3. Computer Assisted: Minnesota River Site

BEND 1							
Evaluator	Radius of Curvature (ft)			Migration Distance (ft)		2021 Predicted Radius of Curvature (ft)	2021 Predicted Migration Distance (ft)
	1950	1968	1991	1950-68	1968-91		
Univ. of Nottingham	538	538	510	50	214	491	229
Ayres Associates	555	562	412	125	265	238	306
Mussetter Eng. Inc.	509	509	440	56	187	354	240
Alabama DOT	559	588	637	108	69	701	88
Alaska DOT	NC	NC	NC	NC	NC	NC	NC
California DOT	570	540	430	50	120	287	157
Georgia DOT	NC	NC	NC	NC	NC	NC	NC
Maryland DOT	376	408	NC	233	NC	(pred. for 1980)	(pred. for 1980)
Nevada DOT	NC	NC	NC	NC	NC	NC	NC
Wyoming DOT	NC	NC	NC	NC	NC	NC	NC
City of Austin, TX	NC	NC	NC	NC	NC	NC	NC
Author	529	568	461	61	180	321	235
Mean	519	530	482	98	173	399	209
Standard Deviation	66	60	83	67	69	171	76
BEND 2							
Evaluator	Radius of Curvature (ft)			Migration Distance (ft)		2021 Predicted Radius of Curvature (ft)	2021 Predicted Migration Distance (ft)
	1950	1968	1991	1950-68	1968-91		
Univ. of Nottingham	585	585	577	164	61	709	73
Ayres Associates	555	525	555	95	35	591	39
Mussetter Eng. Inc.	276	364	423	80	62	505	79
Alabama DOT	578	568	588	69	69	617	88
Alaska DOT	NC	NC	NC	NC	NC	NC	NC
California DOT	560	560	590	25	50	629	65
Georgia DOT	NC	NC	NC	NC	NC	NC	NC
Maryland DOT	404	464	NC	136	NC	(pred. for 1980)	(pred. for 1980)
Nevada DOT	NC	NC	NC	NC	NC	NC	NC
Wyoming DOT	NC	NC	NC	NC	NC	NC	NC
City of Austin, TX	NC	NC	NC	NC	NC	NC	NC
Author	559	541	559	148	74	582	97
Mean	502	515	549	102	59	606	74
Standard Deviation	117	77	63	49	14	67	20
BEND 3							
Evaluator	Radius of Curvature (ft)			Migration Distance (ft)		2021 Predicted Radius of Curvature (ft)	2021 Predicted Migration Distance (ft)
	1950	1968	1991	1950-68	1968-91		
Univ. of Nottingham	668	691	658	88	248	577	141
Ayres Associates	605	610	625	75	115	643	132
Mussetter Eng. Inc.	617	594	617	41	102	650	131
Alabama DOT	559	696	676	108	88	647	118
Alaska DOT	NC	NC	NC	NC	NC	NC	NC
California DOT	620	620	720	50	100	850	130
Georgia DOT	NC	NC	NC	NC	NC	NC	NC
Maryland DOT	364	424	NC	104	NC	(pred. for 1980)	(pred. for 1980)
Nevada DOT	NC	NC	NC	NC	NC	NC	NC
Wyoming DOT	NC	NC	NC	NC	NC	NC	NC
City of Austin, TX	NC	NC	NC	NC	NC	NC	NC
Author	674	623	659	147	69	706	90
Mean	587	608	659	88	120	679	124
Standard Deviation	106	90	37	36	64	93	18

Table C3. Computer Assisted: Minnesota River Site (Cont.)

BEND 4							
Evaluator	Radius of Curvature (ft)			Migration Distance (ft)		2021 Predicted Radius of Curvature (ft)	2021 Predicted Migration Distance (ft)
	1950	1968	1991	1950-68	1968-91		
Univ. of Nottingham	872	923	941	27	210	1050	187
Ayres Associates	775	795	610	70	310	397	357
Mussetter Eng. Inc.	755	732	666	100	199	584	256
Alabama DOT	843	813	637	157	314	461	412
Alaska DOT	NC	NC	NC	NC	NC	NC	NC
California DOT	880	920	800	0	150	643	196
Georgia DOT	NC	NC	NC	NC	NC	NC	NC
Maryland DOT	NC	NC	NC	NC	NC	NC	NC
Nevada DOT	NC	NC	NC	NC	NC	NC	NC
Wyoming DOT	NC	NC	NC	NC	NC	NC	NC
City of Austin, TX	NC	NC	NC	NC	NC	NC	NC
Author	774	700	598	145	225	465	293
Mean	817	814	709	83	235	600	284
Standard Deviation	55	93	135	63	65	238	89
BEND 5							
Evaluator	Radius of Curvature (ft)			Migration Distance (ft)		2021 Predicted Radius of Curvature (ft)	2021 Predicted Migration Distance (ft)
	1950	1968	1991	1950-68	1968-91		
Univ. of Nottingham	NC	NC	NC	NC	NC	NC	NC
Ayres Associates	750	845	865	50	150	888	174
Mussetter Eng. Inc.	705	705	807	88	113	935	144
Alabama DOT	833	764	892	206	39	1088	49
Alaska DOT	NC	NC	NC	NC	NC	NC	NC
California DOT	900	730	930	200	100	1191	130
Georgia DOT	NC	NC	NC	NC	NC	NC	NC
Maryland DOT	NC	NC	NC	NC	NC	NC	NC
Nevada DOT	NC	NC	NC	NC	NC	NC	NC
Wyoming DOT	NC	NC	NC	NC	NC	NC	NC
City of Austin, TX	NC	NC	NC	NC	NC	NC	NC
Author	702	635	674	223	165	725	215
Mean	778	736	834	153	113	965	142
Standard Deviation	86	77	100	79	49	181	62

Table C4. ARCVIEW: Minnesota River Site

BEND 1							
Evaluator	Radius of Curvature (ft)			Migration Distance (ft)		2021 Predicted Radius of Curvature (ft)	2021 Predicted Migration Distance (ft)
	1950	1968	1991	1950-68	1968-91		
Univ. of Nottingham	550	496	429	94	180	341	234
Ayres Associates	604	532	495	101	144	447	188
Mussetter Eng. Inc.	NC	NC	NC	NC	NC	NC	NC
Alabama DOT	596	609	652	125	73	708	95
Alaska DOT	NC	NC	NC	NC	NC	NC	NC
California DOT	600	518	453	115	157	370	205
Georgia DOT	NC	NC	NC	NC	NC	NC	NC
Maryland DOT	NC	NC	NC	NC	NC	NC	NC
Nevada DOT	NC	NC	NC	NC	NC	NC	NC
Wyoming DOT	NC	NC	NC	NC	NC	NC	NC
City of Austin, TX	NC	NC	NC	NC	NC	NC	NC
Author	534	312	330	196	231	353	301
Mean	577	493	472	126	157	444	205
Standard Deviation	32	110	118	41	58	153	75
BEND 2							
Evaluator	Radius of Curvature (ft)			Migration Distance (ft)		2021 Predicted Radius of Curvature (ft)	2021 Predicted Migration Distance (ft)
	1950	1968	1991	1950-68	1968-91		
Univ. of Nottingham	539	542	581	95	41	630	53
Ayres Associates	599	559	572	143	43	590	56
Mussetter Eng. Inc.	580	548	582	145	26	625	33
Alabama DOT	587	583	607	75	62	638	81
Alaska DOT	NC	NC	NC	NC	NC	NC	NC
California DOT	539	529	553	106	37	584	48
Georgia DOT	NC	NC	NC	NC	NC	NC	NC
Maryland DOT	NC	NC	NC	NC	NC	NC	NC
Nevada DOT	NC	NC	NC	NC	NC	NC	NC
Wyoming DOT	NC	NC	NC	NC	NC	NC	NC
City of Austin, TX	NC	NC	NC	NC	NC	NC	NC
Author	582	532	565	185	32	608	42
Mean	571	549	576	125	40	613	52
Standard Deviation	26	20	18	40	12	22	16
BEND 3							
Evaluator	Radius of Curvature (ft)			Migration Distance (ft)		2021 Predicted Radius of Curvature (ft)	2021 Predicted Migration Distance (ft)
	1950	1968	1991	1950-68	1968-91		
Univ. of Nottingham	664	641	583	50	138	508	180
Ayres Associates	665	657	666	29	99	678	130
Mussetter Eng. Inc.	669	653	648	40	104	642	136
Alabama DOT	698	684	671	118	82	654	107
Alaska DOT	NC	NC	NC	NC	NC	NC	NC
California DOT	655	655	663	34	96	673	125
Georgia DOT	NC	NC	NC	NC	NC	NC	NC
Maryland DOT	NC	NC	NC	NC	NC	NC	NC
Nevada DOT	NC	NC	NC	NC	NC	NC	NC
Wyoming DOT	NC	NC	NC	NC	NC	NC	NC
City of Austin, TX	NC	NC	NC	NC	NC	NC	NC
Author	629	482	611	186	116	779	151
Mean	663	629	640	76	106	656	138
Standard Deviation	22	73	35	63	19	87	25

Table C4. ARCVIEW: Minnesota River Site (Cont.)

BEND 4							
Evaluator	Radius of Curvature (ft)			Migration Distance (ft)		2021 Predicted Radius of Curvature (ft)	2021 Predicted Migration Distance (ft)
	1950	1968	1991	1950-68	1968-91		
Univ. of Nottingham	494	678	831	163	190	1031	248
Ayres Associates	834	916	980	12	146	1063	190
Mussetter Eng. Inc.	900	904	953	78	132	1016	172
Alabama DOT	841	875	675	103	340	414	444
Alaska DOT	NC	NC	NC	NC	NC	NC	NC
California DOT	848	867	947	67	98	1051	128
Georgia DOT	NC	NC	NC	NC	NC	NC	NC
Maryland DOT	NC	NC	NC	NC	NC	NC	NC
Nevada DOT	NC	NC	NC	NC	NC	NC	NC
Wyoming DOT	NC	NC	NC	NC	NC	NC	NC
City of Austin, TX	NC	NC	NC	NC	NC	NC	NC
Author	811	785	607	123	224	375	292
Mean	788	837	832	91	188	825	246
Standard Deviation	147	91	158	52	86	334	113
BEND 5							
Evaluator	Radius of Curvature (ft)			Migration Distance (ft)		2021 Predicted Radius of Curvature (ft)	2021 Predicted Migration Distance (ft)
	1950	1968	1991	1950-68	1968-91		
Univ. of Nottingham	866	852	728	102	260	566	339
Ayres Associates	845	862	898	79	167	945	218
Mussetter Eng. Inc.	968	942	905	105	222	856	289
Alabama DOT	737	700	905	225	128	1172	167
Alaska DOT	NC	NC	NC	NC	NC	NC	NC
California DOT	915	821	872	207	160	938	209
Georgia DOT	NC	NC	NC	NC	NC	NC	NC
Maryland DOT	NC	NC	NC	NC	NC	NC	NC
Nevada DOT	NC	NC	NC	NC	NC	NC	NC
Wyoming DOT	NC	NC	NC	NC	NC	NC	NC
City of Austin, TX	NC	NC	NC	NC	NC	NC	NC
Author	673	514	961	262	365	1544	476
Mean	834	782	878	163	217	1003	283
Standard Deviation	110	153	79	77	87	329	113
NC = Not Completed							

Table C5. Summary of Beta-Test Results.

SIMPLE OVERLAY VS. ARCVIEW TECHNIQUE:								
SACRAMENTO RIVER SITE								
BEND 1								
Method		Radius of Curvature (ft)			Migration Distance (ft)		2028 Predicted Radius of Curvature (ft)	2028 Predicted Migration Distance (ft)
		1937	1972	1998	1937-72	1972-98		
SIMPLE OVERLAY	Mean	909	1913	1558	2398	1328	1196	1521
	Std. Dev.	227	325	274	1137	222	528	260
	% SD/M	25	17	18	47	17	44	17
ARCVIEW	Mean	1335	2163	1877	2441	1603	1560	1705
	Std. Dev.	334	477	393	786	328	381	443
	% SD/M	25	22	21	32	20	24	26
BEND 2								
Method		Radius of Curvature (ft)			Migration Distance (ft)		2028 Predicted Radius of Curvature (ft)	2028 Predicted Migration Distance (ft)
		1937	1972	1998	1937-72	1972-98		
SIMPLE OVERLAY	Mean	2095	1497	1447	2309	1243	1392	1423
	Std. Dev.	622	343	196	334	188	337	215
	% SD/M	30	23	14	14	15	24	15
ARCVIEW	Mean	2494	1562	1488	2135	1874	1404	1900
	Std. Dev.	375	152	50	315	79	193	302
	% SD/M	15	10	3	15	4	14	16
COMPUTER ASSISTED (POWERPOINT) OVERLAY VS. ARCVIEW TECHNIQUE:								
MINNESOTA RIVER SITE								
BEND 1								
Method		Radius of Curvature (ft)			Migration Distance (ft)		2021 Predicted Radius of Curvature (ft)	2021 Predicted Migration Distance (ft)
		1950	1968	1991	1950-68	1968-91		
COMPUTER ASSISTED	Mean	519	530	482	98	173	399	209
	Std. Dev.	66	60	83	67	69	171	76
	% SD/M	13	11	17	68	40	43	36
ARCVIEW	Mean	577	493	472	126	157	444	205
	Std. Dev.	32	110	118	41	58	153	75
	% SD/M	6	22	25	32	37	35	37
BEND 2								
Method		Radius of Curvature (ft)			Migration Distance (ft)		2021 Predicted Radius of Curvature (ft)	2021 Predicted Migration Distance (ft)
		1950	1968	1991	1950-68	1968-91		
COMPUTER ASSISTED	Mean	502	515	549	102	59	606	74
	Std. Dev.	117	77	63	49	14	67	20
	% SD/M	23	15	12	48	24	11	28
ARCVIEW	Mean	571	549	576	125	40	613	52
	Std. Dev.	26	20	18	40	12	22	16
	% SD/M	5	4	3	32	31	4	31
BEND 3								
Method		Radius of Curvature (ft)			Migration Distance (ft)		2021 Predicted Radius of Curvature (ft)	2021 Predicted Migration Distance (ft)
		1950	1968	1991	1950-68	1968-91		
COMPUTER ASSISTED	Mean	587	608	659	88	120	679	124
	Std. Dev.	106	90	37	36	64	93	18
	% SD/M	18	15	6	42	54	14	15
ARCVIEW	Mean	663	629	640	76	106	656	138
	Std. Dev.	22	73	35	63	19	87	25
	% SD/M	3	12	6	82	18	13	18
BEND 4								
Method		Radius of Curvature (ft)			Migration Distance (ft)		2021 Predicted Radius of Curvature (ft)	2021 Predicted Migration Distance (ft)
		1950	1968	1991	1950-68	1968-91		
COMPUTER ASSISTED	Mean	817	814	709	83	235	600	284
	Std. Dev.	55	93	135	63	65	238	89
	% SD/M	7	11	19	76	28	40	31
ARCVIEW	Mean	788	837	832	91	188	825	246
	Std. Dev.	147	91	158	52	86	334	113
	% SD/M	19	11	19	57	46	40	46
BEND 5								
Method		Radius of Curvature (ft)			Migration Distance (ft)		2021 Predicted Radius of Curvature (ft)	2021 Predicted Migration Distance (ft)
		1950	1968	1991	1950-68	1968-91		
COMPUTER ASSISTED	Mean	778	736	834	153	113	965	142
	Std. Dev.	86	77	100	79	49	181	62
	% SD/M	11	10	12	51	43	19	43
ARCVIEW	Mean	834	782	878	163	217	1003	283
	Std. Dev.	110	153	79	77	87	329	113
	% SD/M	13	20	9	47	40	33	40

