

National Cooperative Highway Research Program

RESEARCH RESULTS DIGEST

January 2004—Number 285

Subject Areas: IIB Pavement Design, Management,
and Performance and IIIB Materials and Construction

Responsible Senior Program Officer: Edward T. Harrigan

Laboratory Determination of Resilient Modulus for Flexible Pavement Design

This digest presents key findings from NCHRP Project 1-28A, "Harmonized Test Methods for Laboratory Determination of Resilient Modulus for Flexible Pavement Design," conducted by the University of Maryland—College Park. The digest is an abridgement of portions of the project final report by the principal investigator, Matthew W. Witczak, Ph.D., Professor Emeritus, University of Maryland—College Park, and Professor, Arizona State University, Tempe, Arizona.

This digest presents the two key products from research conducted under NCHRP Project 1-28A, "Harmonized Test Methods for Laboratory Determination of Resilient Modulus for Flexible Pavement Design." The objective of Project 1-28A was to develop (1) a test method for measurement of the resilient modulus of hot mix asphalt (HMA) that harmonizes the procedure proposed by NCHRP Project 1-28 with the existing AASHTO TP31 method and the FHWA LTPP *Laboratory Start-Up and Quality Control Procedure* and (2) a test method for measurement of the resilient modulus of unbound granular base and subbase materials and subgrade soils that harmonizes the procedure proposed by Project 1-28 with the existing AASHTO TP46, T 292, and T 294 methods and the FHWA LTPP *Laboratory Start-Up and Quality Control Procedure*.

The resilient modulus, M_R , of unbound base, subbase, and subgrade materials is a key input property for the mechanistic-empirical pavement design procedure developed in NCHRP Project 1-37A, "Development of the 2002 Guide for the Design of New and Rehabilitated Pavement Structures: Phase II." Inaccurate determination of the resilient modulus of the unbound materials in the pavement structure will contribute to erroneous predictions of overall pavement response and pavement performance.

NCHRP Project 1-28, "Laboratory Determination of Resilient Modulus for Flexible Pavement Design," completed in 1997 by the Georgia Institute of Technology, produced an excellent set of findings

relative to the M_R characterization of (1) HMA materials through the indirect tensile (diametral) test and (2) unbound base and subbase materials and subgrade soils through the triaxial test. The test procedures recommended by Project 1-28 more accurately accounted for the effects of varying field conditions, such as temperature of the HMA surface layer or the moisture content of the base, subbase, and subgrade, on the resilient modulus.

The resilient modulus procedure proposed by NCHRP 1-28 for measuring M_R of HMA mixtures enhanced earlier ASTM, AASHTO, and SHRP procedures to achieve a reduced testing time and more reproducible test results. The resilient modulus procedure proposed for unbound materials and soil made use of the grain size distribution and the plasticity index to classify the materials for test purposes. Axial deformation is measured on the sample and the load cell is located inside the triaxial cell. For very soft specimens that may be damaged by clamps, the measurements are made between the top and bottom platens. Besides clamp-mounted LVDTs, more accurate sensors (e.g., optical extensometers and non-contact sensors) could be used to measure the axial deformations. Three alternative test procedures that take into account both the behavior of the material (granular or fine-grained) and its function within the flexible pavement structure are provided. Scalping and replacing techniques are used to reduce variability in test results. The predictive equation takes into account the effects of both the deviatoric and the volumetric component of the loading in the form

CONTENTS

Laboratory Determination of Resilient Modulus for Flexible Pavement Design, 1

APPENDIX 1 Recommended Standard Test Method for Determining the Resilient Modulus of Bituminous Mixtures by Indirect Tension, 4

APPENDIX 2 Recommended Standard Method for Routine Resilient Modulus Testing of Unbound Granular Base/Subbase Materials and Subgrade Soils, 12

Annex A-1 Sample Preparation (Mandatory Information), 31

Annex A-2 Vibratory Compaction, 33

Annex A-3 Impact Compaction, 36

Annex A-4 Kneading Compaction, 40

Annex A-5 Specimen End Preparation, 44

Annex A-6 Obtaining a Uniform Density in Type 3 Soils, 46

of a three-parameter, log-log model based on the cyclic stress and confining pressure.

Project 1-28 thus provided yet another set of test protocols for M_R in competition with several existing methods. This was especially true for unbound materials and soil where there were then three other methods in widespread use, namely, AASHTO T 292, AASHTO T 294, and AASHTO TP46 (now AASHTO T 307). The Project 1-28 panel judged that further work was warranted to harmonize these existing, competing methods with those developed in Project 1-28 to produce a single recommended method each

for HMA and unbound materials that would reflect the best currently available practice in M_R testing.

The research necessary to accomplish this harmonization was conducted in Project 1-28A. The remainder of this digest presents the two recommended methods developed in Project 1-28A to measure the M_R of HMA mixtures (Appendix 1) and unbound materials and soil (Appendix 2) in AASHTO standard format. The complete final report for Project 1-28A, which contains substantial supporting test data and analyses for the development of these methods, is available for loan on request to NCHRP.

APPENDIX 1. RECOMMENDED STANDARD TEST METHOD FOR DETERMINING THE RESILIENT MODULUS OF BITUMINOUS MIXTURES BY INDIRECT TENSION

1. SCOPE

1.1 General

This proposed protocol describes procedures for the determination of the resilient modulus of hot mix asphalt (HMA) concrete, using repeated load indirect tensile test techniques. The procedure involves resilient modulus testing at 77°F.

1.2 Testing Prerequisites

Resilient modulus testing shall be conducted after system response has been verified by testing synthetic specimens, as outlined in Section 8.1 of this protocol.

1.3 Sample Size

Resilient modulus testing shall be conducted on 6-inch-diameter specimens that are 1.5 inches to 2.5 inches in thickness. The test specimens can be obtained from field coring or from a gyratory-compacted specimen. Depending on the height of the gyratory-compacted specimen and the thickness of the test specimen, two or three specimens can be sawed from the gyratory plug.

1.4 Pretest Tensile Strength

Prior to performing the resilient modulus test, the indirect tensile strength shall be determined for one test specimen taken from the same layer and as close as possible to the location of the core specimen(s) to be tested for resilient modulus. For laboratory specimens, a sample having the same mix properties will be selected for indirect tensile strength testing. The indirect tensile strength test is performed as a basis for selecting the loading levels for the resilient modulus testing. The test shall be performed in accordance with Attachment A of SHRP P07 protocol (November 1, 1992).

1.5 Definitions

The following definitions are used throughout this protocol:

- (a) Layer – that part of the pavement produced with similar material and placed with similar equipment and techniques. The layer thickness can be equal to or less than the core thickness or length.
- (b) Core – an intact cylindrical specimen of pavement materials, which is removed from the pavement by drill-

ing and sampling at the designated core location. A core may consist of, or include, one, two, or more than two different layers.

- (c) Test Specimen – that part of the layer, which is used for, or in, the specified test. The thickness of the test specimen can be equal to or less than the layer thickness.
- (d) Haversine-Shaped Load Form - the required load pulse from the resilient modulus test. The load pulse is in the form $(1 - \cos \theta) / 2$ and the cyclic load is varied from the contact load (P_{contact}) to the maximum load (P_{max}), as shown in Figure C-1 (from SHRP P07 protocol).
- (e) Maximum Applied Load (P_{max}) – the maximum total load applied to the sample, including the contact and cyclic (resilient) loads.

$$P_{\text{max}} = P_{\text{contact}} + P_{\text{cyclic}}$$
- (f) Contact Load (P_{contact}) – the vertical load placed on the specimen to maintain a positive contact between the loading trip and the specimen. The contact load is 4% of the maximum load ($0.04 P_{\text{max}}$) and is not less than 5 lbs, but not more than 20 lbs.
- (g) Cyclic Load (Resilient Vertical Load, P_{cyclic}) – load applied to a specimen, which is directly used to calculate resilient modulus.

$$P_{\text{cyclic}} = P_{\text{max}} - P_{\text{contact}}$$
- (h) Instantaneous Resilient Modulus – determined from the deformation-time plots (both horizontal and vertical) as described herein.

To determine the instantaneous deformation values, it is recommended to perform regression in three portions of the deformation curve:

1. Linear regression in the straight portion of the unloading path.
2. Regression in the curved portion that connects the unloading path and the recovery portion to yield the following hyperbolic equation:

$$Y = a + b/X$$

Where

- Y = deformation value,
- X = time, and
- a, b = regression constants

3. Regression in the recovery portion between 40% and 90% (recommended range) of the rest period to

yield a hyperbolic equation. A tangent should be drawn to this hyperbola at the point corresponding to 55% (recommended point) of the rest period.

Two linear equations, one from the unloading path and other from the tangent of the hyperbola in the recovery period, shall be solved to determine the intersection. Then the point on the hyperbolic curve corresponding to the time coordinate of the intersection (for convenience, say point A) is selected to determine the instantaneous deformation by subtracting the deformation at the point A from the peak deformation.

- (i) Total Resilient Modulus – determine from the deformation-time plots (both horizontal and vertical) by subtracting deformation obtained at the end of one load-unload cycle, as determined by taking the average of deformation values obtained for the time period between 85% completion and 95% completion of the rest period from the peak deformation values. This value includes both the instantaneous recoverable deformation and the time-dependent continuing recoverable deformation during the rest period portion of one cycle.

2. APPLICABLE DOCUMENTS

SHRP Protocol P07, Resilient Modulus for Asphalt Concrete (November 1, 1992)

3. SUMMARY OF METHOD

- 3.1 The repeated-load indirect tension resilient modulus test of asphalt concrete is conducted through repetitive applications of compressive loads in a haversine waveform. The compressive load is applied along a diametral plane of a cylindrical asphalt concrete specimen. The resulting horizontal and vertical deformations are measured. Values of resilient Poisson's ratio shall be calculated using recoverable vertical and horizontal deformations. The resilient modulus values are subsequently calculated using the calculated Poisson's ratio.
- 3.2 Two separate resilient modulus values are obtained. One, termed *instantaneous* resilient modulus, is calculated using the recoverable horizontal deformation that occurs during the unloading portion of one load-unload cycle. The other, termed *total* resilient modulus, is calculated using recoverable deformation which includes both the instantaneous recoverable and time-dependent continuing recoverable deformation during the unload or rest-period portion of one cycle.

3.3 For each resilient modulus test, the following general procedures must be followed:

- (a) The tensile strength is determined on the test specimen at $77 \pm 2^\circ\text{F}$ using the procedure described in Attachment A of the SHRP P07 protocol. The value of tensile strength obtained from this procedure is used to determine the indirect tensile stress and corresponding compressive load to be respectively applied to the test specimens during the resilient modulus determination.
- (b) The test specimen(s) are to be tested along two perpendicular diametral axes at test temperatures of $77 \pm 2^\circ\text{F}$. Repetitive haversine load pulses of 0.1-second duration followed by a rest period of 0.9 seconds between load pulses are applied to the individual test specimens. The magnitude of the load pulse will be selected to produce a predefined indirect tensile stress on the specimen based on a percentage of the indirect tensile strength (see Section 3.3(a) above).
- (c) After completion of resilient modulus testing along the two perpendicular diametral planes, indirect tensile strength testing shall be performed in accordance with Attachment A of the SHRP P07 protocol. This test is performed to determine the tensile strength of the specific specimen actually used in resilient modulus testing. For this specimen the loading axis shall be 90° to the second diametral axis used for modulus determination.

4. SIGNIFICANCE AND USE

Resilient modulus can be used in evaluation of materials quality and as input for pavement design, evaluation, and analysis. With this method, the effects of temperature and load on resilient modulus can also be investigated.

5. APPARATUS

5.1 Testing Machine

The testing machine shall be a top-loading, closed-loop, electro-hydraulic testing machine with a function generator capable of applying a haversine-shaped load pulse over a range of load durations, load levels, and rest periods.

5.2 Loading Device

The loading device should be capable of testing 6-inch-diameter specimens of heights up to 2.5 inches. The device should be compact enough to be used within the environ-

mental chamber. It should have a fixed bottom loading plate and a moving upper loading plate. The movement of the upper plate should be guided by two columns, one on each side of the specimen and equidistant from the loading axis and the loading strips, to ensure it has minimal translational or rotational motion during loading of the specimen. The guide columns shall have a frictionless bearing surface that shall be kept well lubricated. The surface of the guide columns shall be frequently inspected for any grooves caused due to friction. Alignment of the device, within the loading system, shall be achieved so that such friction is limited to the minimum possible extent. The upper plate shall be rigid enough to prevent any deflections during loading. If heavy-weight plates are used to achieve rigidity, the testing should be able to counteract all the weight, such that no more than 2 lbs. of load is transferred to the specimen when the load is not being applied. It is recommended that high-strength material be used to achieve rigidity and keep the weight small. The loading strips preferably shall be perpendicular to the line connecting the two guide columns, so that visual alignment of the sample in the device is easier.

5.3 Temperature Control System

The temperature control system should be capable of maintaining temperature within 2°F (1.1°C), at a setting value of 77°F (25°C). The system shall include a temperature-controlled cabinet large enough to house the loading device and a cabinet adequate to pre-condition at least three test specimens at a time prior to testing.

5.4 Measurement and Recording System

The measuring and recording system shall include sensors for measuring and simultaneously recording horizontal and vertical deformations and loads. The system shall be capable of recording horizontal and vertical deformations in the range of 0.000015 inch (0.00038 mm) of deformation. Load cells shall be accurately calibrated with a resolution of 2 lbs. or better.

5.4.1 Data Acquisition – The measuring or recording devices must provide real-time deformation and load information and should be capable of monitoring readings on tests conducted to 1 Hz. Computer monitoring systems are recommended. The data acquisition system shall be capable of collecting 200 scans per second (a scan includes all deformation and load values at a given point of time). The capability to have real-time plots (simultaneous to the data collection by the computer monitoring system) shall also be provided to check the progress of the test. If strip chart recorders are used without computer monitoring systems, the plotting scale shall be adjusted such that there is a balance between the scale reduction required as a result of the pen reaction time and the

scale amplification needed for purposes of accurate measurement of values from a plot.

Actual load values, and not the intended load values, shall be used for calculation purposes and so the data acquisition system shall also be capable of monitoring the load values continuously during testing.

5.4.2 Deformation Measurement – Both horizontal and vertical deformation shall be measured on the surface of the specimen by mounting LVDTs between gage points along the horizontal and vertical diameters. The gage length shall be one-half of the diameter of the specimen (3 inches for a 6-inch-diameter specimen). It is required to have the two LVDTs, on each face of the specimen, one horizontal and one vertical resulting in a total of four LVDTs for deformation measurement. Extensometers, if used, should also be calibrated from time to time. The surfaces on which the knife-edges of the extensometer assembly rest should be kept smooth and free of grooves.

5.4.3 Load Measurements – The repetitive loads shall be measured with an electronic load cell with a capacity adequate for the maximum required loading and a sensitivity of 0.5% of the intended peak load.

During periods of resilient modulus testing, the load cell shall be monitored and checked once a month with a calibrated proving ring to ensure that the load cell is operating properly. Additionally, the load cell shall be checked at any time that the QA/QC testing with in-house synthetic specimen (Section 8.1) indicates a change in the system response or when there is a suspicion of a load cell problem.

5.5 Loading Strips

Steel loading strips, with concave sample contact surfaces, machined to the radius of curvature of a 6.000 ± 0.006 -inch-diameter specimen, are required to apply load to the test specimens. The contact area of the loading strip shall be $\frac{3}{4}$ inches wide. The outer edges of the curved surface shall be filed lightly to remove sharp edges that might cut the specimen during testing. Thin lines should be drawn along the length of the strip at its center, to help alignment. Also, appropriate marking should be made so as to center the specimens within the length of the strips. This could be either done by matching the center of specimen with a mark at the center of the strip or by positioning the specimen between two marks at the ends of the specimen thickness, or both.

5.6 Marking and Alignment Devices

A marking device shall be used to mark mutually perpendicular axes on the top and bottom faces of the specimen

through the center. The axes shall be simultaneously marked on the top and bottom faces of the specimen to ensure that the axes on the front and the back lie in a single plane.

An alignment device shall be used to position and place horizontal and vertical LVDTs along the horizontal and vertical diameter of the specimen and hold it there, until the glue that holds the LVDTs cures. It shall be easily removable, without disturbing the LVDT (once the glue cures), and shall not be destructively mounted on the specimen. The device preferably shall have the capability to mount the LVDT at different gage lengths but mainly at a gage length of one-half of the diameter of the specimen. The LVDT shall be as close as possible to (but not touching) the surface of the specimen so as to minimize the bulging effect. To ensure uniform test results, a height of 0.2 inch is recommended. The axis of the LVDT shall not be at a distance greater than 0.25 inch from the surface of the specimen.

6. TEST SPECIMEN

6.1 Core Specimen - cores for test specimen preparation, which may contain one or more testable layers, must have smooth and uniform vertical (curved) surfaces and must be no less than 5.85 inches and no more than 6.15 inches in diameter. Cores that are obviously deformed or have any visible cracks must be rejected. Irregular top and bottom surfaces shall be trued as necessary, and individual layer specimens shall be obtained by cutting with a diamond saw using water or air as a coolant.

6.2 The test specimen designated for testing shall not be more than 2.5 inches thick. However, for base course or large-stone mixes, the thickness shall not be greater than 3.5 inches. If a core specimen has more than one layer, the layers shall be separated at the layer interface by sawing. Layers containing more than one lift of the same material as placed under contract specification may be tested as a single specimen. Traffic direction shall be marked on each layer after cutting, to maintain the correct orientation. Layers too thin to test (less than 1.5 inches for 6-inch-diameter specimens), as well as any thin surface treatments, shall be removed and discarded.

A test specimen shall consist of a single pavement material or layer greater than 1.5 inches thick. The desired thickness for testing is approximately 2.0 inches for a 6-inch-diameter specimen. If the thickness of a particular asphalt concrete (AC) layer scheduled for testing is 1 inch or more greater than the desired testing thickness, then the specimen to be used for testing shall be obtained from the middle of the AC layer. If the specimen has relatively smooth top and bottom faces, then no sawing is required and the specimen may be tested as is.

6.3 Diametral Axis – Marking of the diametral axis to be tested shall be done using a suitable marking device as described in Section 5.6. The axis shall be parallel to the traffic direction symbol (arrow) or “T” marked during the field coring operations. This diametral axis location can be rotated slightly, if necessary, to avoid contact of the loading strips with abnormally large aggregate particles or surface voids or to avoid the mounting of the vertical LVDT over large surface voids. The second marking will be perpendicular to the first marked diametral axis. These marking are required for mounting horizontal and vertical LVDTs.

6.4 The thickness (t) of each test specimen shall be measured to the nearest 0.01 inch (0.25 mm) prior to testing. The thickness shall be determined by averaging four measurements located at $1/4$ points around the sample perimeter, and $1/2$ - to 1-inch in from the specimen edge.

6.5 The diameter (D) of each test specimen shall be determined prior to testing to the nearest 0.01 inch (0.25 mm) by averaging diametral measurements. Measure the diameter of the specimen at mid-height along (1) the axis parallel to the direction of traffic and (2) the axis perpendicular (90 degrees) to the axis measured in (1) above. The two measurements shall be averaged to determine the diameter of the test specimen.

7. PROCEDURE

7.1 General

For deformation measurement in both the horizontal and vertical directions, mount the gage points by gluing them to the test specimen. Wait until the gage points are properly set and the glue is dry. The asphalt cores are then placed in a controlled temperature cabinet/chamber and brought to the specified test temperature. Unless the core specimen temperature is monitored in some manner and the actual temperature known, the core samples shall remain in the cabinet/chamber at 77°F (25°C) for a minimum of 6 hours prior to testing.

- (a) Determine the tensile strength of the test specimens at $77^{\circ} \pm 2^{\circ}\text{F}$ using the procedure described in Attachment A to SHRP Protocol P07.
- (b) The test specimen(s) designated for resilient modulus testing shall be brought to the test temperature ($77^{\circ} \pm 2^{\circ}\text{F}$) as specified in Section 7.1.
- (c) Attach the LVDTs on the two faces of the specimen, arranged as two horizontal and two vertical LVDTs. The electronic measuring system shall be adjusted and gains set as necessary for the four LVDTs. Prior to

testing, zero the extensometers and the surface-mounted LVDTs. An initial negative offset might be necessary if high gain is being used and/or there is a possibility of exceeding the range of voltage otherwise.

7.2 Alignment and Specimen Seating

Position the test specimen so that the mid-thickness mark (cross mark for the two diametral axes) on the test specimen is located in the line of action of the actuator shaft or, alternately, ascertain that the specimen is centered exactly between end markings on loading strips. The diametral markings are then used to ensure that the specimen is aligned from top to bottom and front to back. The alignment of the front face of the specimen can be checked by ensuring that the diametral marking is centered on the top and bottom loading strips. With the use of a mirror, the back face can be similarly aligned.

The contact surface between the specimen and each loading strip is critical for proper test results. Any projections or depressions in the specimen-to-strip contact surface, which leave the strip in non-contact condition over a length of more than 0.75 inch after completion of the load conditioning stage, shall be reason for rotating the test axis or rejecting the specimen. If no suitable replacement specimen is available, the test shall be conducted on the available sample and the situation documented.

7.3 Preconditioning

Preconditioning and testing shall be conducted while the specimen is located in a temperature-controlled cabinet meeting the requirements of Section 5.3.

7.3.1 Selection of applied loads for preconditioning and testing at the test temperature is based on the indirect tensile strength, determined as specified in Attachment A to SHRP Protocol P07. Tensile stress levels of 15% of the tensile strength measured at 77°F are to be used in conducting the test at temperatures of 77° ± 2°F. Specimen contact loads specified in Section 1.5 (e) shall be maintained during testing.

7.3.2 The sequence of resilient modulus testing shall consist of initial testing along the first diametral axis (or along the traffic direction for the field cores) followed by rotating the specimen 90 degrees. The test specimen must be maintained at 77°F. The computer-generated waveform shall be as closely matched as possible by adjusting the gains. The number of load applications to be applied for each rotation for preconditioning cycles is 100. However, the minimum number of load applications for a given situation must be such that the resilient modulus deformations are stable (Section 7.5.1). When using more preconditioning cycles, the number of pre-

conditioning cycles shall be recorded and the reason documented. Also, if a specimen has to be realigned, or when precondition has to be stopped for any other reason, sufficient time should be given to the specimen for relaxation before resuming the test.

7.4 Horizontal and Vertical Deformation

Both the horizontal and vertical deformations shall be monitored during preconditioning. If total cumulative vertical deformations greater than 0.03 inch occur, the applied load shall be reduced to the minimum value possible and still retain adequate deformations for measurement purposes. If use of smaller load levels are not adequate for measurement purposes, discontinue preconditioning and generate 10 load pulses for resilient modulus determination and so indicate on the test report.

7.5 Testing

At the end of preconditioning for each rotation, the resilient modulus testing shall be conducted as specified below.

7.5.1 Record the measured deformation individually from the four deformation measuring devices and the load sensor as soon as preconditioning is over (the load pulses are to be applied continuously through preconditioning and data collection for resilient modulus). The response is only recorded (deformation and load) for the last five loading cycles of the total applied load pulses. One loading cycle consists of one load pulse and a subsequent rest period. The resilient modulus will be calculated and reported for each cycle using the equations in Section 9 of this protocol.

7.5.2 After the specimen has been tested along the first diametral plane, rotate the specimen 90 degrees and repeat Sections 7.3.2 through 7.5.1 of this protocol.

7.5.3 After testing is completed for both the diametral axes, the specimen shall be brought to a test temperature of 77° ± 2°F and an indirect tensile strength test conducted on the test specimen as specified in Attachment A of SHRP P07.

7.6 Cumulative Deformation

The cumulative horizontal and vertical deformation shall be determined per Attachment C of the SHRP P07 Protocol.

8. QUALITY ASSURANCE/QUALITY CONTROL

8.1 Prior to the start of resilient modulus testing each week, the laboratory testing personnel shall perform testing on

one or more in-house QA/QC synthetic specimens. The synthetic specimen should be selected for QA/QC to provide a response similar to the expected asphalt concrete specimen response at 77°F. Typically, materials such as polyethylene may be used to verify the system response. The synthetic specimens shall be tested at a temperature of 77°F, at a load time of 0.1 second and a rest period of 0.9 second on both the axes at a load level expected for the AC samples.

However, QA/QC testing shall be done whenever alignment of the loading system may have changed.

The specimens shall be tested as follows:

- 8.1.1 The specimen shall be located in a temperature-controlled cabinet meeting the requirements of Section 5.3 and at a temperature of 77°F. The applied loads for preconditioning and testing for the synthetic specimens are defined below.
- 8.1.2 The test specimen shall be preconditioned along the proper axis prior to testing by applying a minimum of 100 cycles of the specified haversine-shaped load pulse of 0.1-second duration with a rest period of 0.9 second. The computer-generated wave form shall be matched as closely as possible by adjusting gains and preconditioning shall continue until both horizontal and vertical deformations are stable and appear to be uniform.
- 8.2 The results from the QA/QC testing shall be stored as a permanent record of the system response to obtain the system fingerprint. If all the synthetic specimens have not been tested for each set of 100 resilient modulus tests, QA/QC testing shall be performed on the remaining synthetic specimens in order to verify the system response.

9. CALCULATIONS

The following equations are intended for the calculation of either instantaneous or total values, depending on whether instantaneous or total deformation values are used. Consider horizontal deformation as positive and vertical deformation as negative. The load value is assumed to be positive.

9.1 Poisson's Ratio

Poisson's ratio shall be calculated from the vertical and horizontal deformation values by the use of the following equations:

$$\mu = \frac{-1.0695 - 0.2339 \frac{\delta_v}{\delta_h}}{0.3074 + 0.7801 \frac{\delta_v}{\delta_h}}$$

where

- μ = instantaneous or total Poisson's ratio,
 δ_v = the recoverable vertical deformation measured over a gage length equal to three quarters of the diameter of the specimen, inches, and
 δ_h = the recoverable horizontal deformation measured over the horizontal diameter of the specimen, inches.

It is expected that the Poisson's ratio is 0.25 to 0.45. When the calculated Poisson's ratio is outside this range, the calculated values shall be reported and a visual inspection of the specimen should be made to study the deformation in shape and/or presence of cracks due to damage, and so reported.

The Poisson's ratio must be calculated for each set of LVDTs (horizontal and vertical). That is, for the first diametral plane, two Poisson's ratio values are estimated. These are obtained from the two faces of the specimen. Another set of Poisson's ratio values are obtained after rotation, resulting in a total of four Poisson's ratio values for a single specimen.

9.2 Resilient Modulus

The resilient modulus can then be calculated from the Poisson's ratio, as obtained from Section 9.1, and the recoverable horizontal deformation (instantaneous or total) according to the following equation.

$$M_R = \frac{P_{cyclic}}{\delta_h t} (0.2339 + 0.7801\mu)$$

where

- M_R = instantaneous or total resilient modulus, psi,
 δ_h = recoverable horizontal deformation, inches,
 $P_{cyclic} = P_{max} - P_{contact}$ = cyclic load applied to specimen, lbs.,
 P_{max} = maximum applied load, lbs.
 $P_{contact}$ = contact load, lbs., and
 μ = instantaneous or total Poisson's ratio.

For each horizontal deformation, the corresponding Poisson's ratio value must be used, resulting in a total of four resilient modulus values for a single specimen.

9.3 Replicates

The test procedure is applicable both for the laboratory-compacted and field cores. In the laboratory, the test speci-

mens are obtained from gyratory compaction. Three test specimens with a total thickness equal to 1.5 inches can be obtained from a gyratory plug compacted to a height of 6 inches. It is recommended that both ends of the gyratory plug be sawed to obtain a smooth surface. This will result in three replicates from a given gyratory plug. In the case of field cores, three field samples are needed from a homogeneous section.

Three test samples will result in a total of twelve Poisson's ratio and resilient modulus values (four values for each sample). It is important to report the individual values, averages, and standard deviations.

10. REPORT

10.1 The following general information shall be recorded:

10.1.1 Sample Identification

10.1.2 Average thickness of the test specimen (t), to the nearest 0.01 inch (per Section 6.4)

10.1.3 Average diameter of the test specimen (D), to the nearest 0.01 inch (per Section 6.5)

10.1.4 Indirect tensile strength (initial), to the nearest psi.; from a comparable test specimen used to select the stress (or load) level for the testing.

10.1.5 Indirect tensile strength (final), to the nearest psi.; for the test specimen after the resilient modulus test has been completed.

10.1.6 Comments: The following (and additional, if so required) comments should be recorded, when relevant.

- (a) If sawing was required for core specimens.
- (b) If the specimen was skewed (either end of the specimen departed from perpendicularity to the axis by more than 0.5 degrees or 1/8 inch in 12 inches), as observed by placing the specimen on a level surface and measuring the departure from perpendicularity.
- (c) If a "dummy" specimen was used to monitor the temperature. If not, the time that the specimen was maintained at the test temperature in the environmental chamber.
- (d) If tests could not be completed due to damage/failure of the test specimen.

(e) If the projections/depressions on the test surface were higher or deeper than 1/16 inch and the specimen was tested because no replacement specimen was available. Record the projections/depressions in such a case.

(f) If, for core specimens, no traffic direction was marked, or if the test was not performed on the marked axis for some reason.

10.2 The following information shall be recorded:

10.2.1 Instantaneous Resilient Modulus

- (a) The vertical load levels (P_{cyclic})
- (b) The contact load ($P_{contact}$) used over the last five loading cycles.
- (c) Instantaneous recoverable horizontal and vertical deformations measured over the last five cycles.
- (d) The calculated instantaneous Poisson's ratio (μ_i) over the last five loading cycles for each temperature.
- (e) The calculated instantaneous resilient modulus (M_{ri}) over the last five loading cycles for each test temperature.
- (f) The average and standard deviation of calculated instantaneous Poisson's ratio and instantaneous resilient modulus for all the replicates used for a given mix type.

10.2.2 Total Resilient Modulus

- (a) The vertical load levels (P_{cyclic})
- (b) The contact load ($P_{contact}$) used over the last five loading cycles.
- (c) Total recoverable horizontal and vertical deformations measured over the last five cycles.
- (d) The calculated total Poisson's ratio (μ_t) over the last five loading cycles for each temperature.
- (e) The calculated total resilient modulus (M_{rt}) over the last five loading cycles for each test temperature.
- (f) The average and standard deviation of calculated total Poisson's ratio and instantaneous resilient modulus for all the replicates used for a given mix type.

10.2.3 Permanent Horizontal and Vertical Deformations

- (a) The number of preconditioning cycles used for each rotation.
- (b) The cumulative permanent vertical deformation measured, including the preconditioning cumulative deformation and the resilient modulus testing cumulative deformation.
- (c) The cumulative permanent horizontal deformation measured, including the preconditioning cumulative deformation and the resilient modulus testing cumulative deformation.
- (d) The total number of load cycles conducted during the test. This includes the number of cycles for preconditioning and those cycles conducted for the determination of resilient modulus.
- (e) The cumulative vertical deformation measured after preconditioning prior to initiation of resilient modulus testing.
- (f) The cumulative horizontal deformation measured after preconditioning prior to initiation of resilient modulus testing.
- (g) The cumulative permanent vertical deformation per load cycle.
- (h) The cumulative permanent horizontal deformation per load cycle.

APPENDIX 2. RECOMMENDED STANDARD METHOD FOR ROUTINE RESILIENT MODULUS TESTING OF UNBOUND GRANULAR BASE/ SUBBASE MATERIALS AND SUBGRADE SOILS

1. SCOPE

- 1.1 This test method describes the laboratory preparation and testing procedures for the routine determination of the resilient modulus (M_r) of unbound granular base/subbase materials and subgrade soils for pavement design. The stress conditions used in the test represent the range of stress states likely to be developed beneath flexible pavements subjected to moving wheel loads. The test procedure has been adapted from the standard test methods given by NCHRP 1-28 Draft Final Report Appendix E and AASHTO DESIGNATION: T 294-92, TP 46 and T 292-91.
- 1.2 The methods described herein are applicable to (1) undisturbed samples of natural and compacted subgrade soils and (2) disturbed samples of unbound base, subbase, and subgrade soils prepared for testing by compaction in the laboratory.
- 1.3 In this test procedure, stress states used for resilient modulus testing are based on whether the specimen is located in the base/subbase or the subgrade. Specimen size for testing depends on the maximum particle size of the material.
- 1.4 The value of the resilient modulus determined from this procedure is a measure of the elastic modulus of unbound base and subbase materials and subgrade soils, recognizing its nonlinear variation with deviatoric stress and confining pressure.
- 1.5 Resilient modulus values can be used with structural response analysis models to calculate the pavement structural response to wheel loads and with pavement design procedures to design pavement structures.
- 1.6 The values stated in SI units are to be regarded as the standard.
- 1.7 This standard may involve hazardous materials, operations, and equipment. This standard does not purport to address all of the safety problems associated with its use. It is the responsibility of whoever uses this standard to consult and establish appropriate safety and health practices and determine the applicability of regulatory limitations prior to use.

Note 1 – Test specimens and equipment described in this method may be used to obtain other useful and related information such as the Poisson's ratio and rutting charac-

teristics of subgrade soils and base/subbase materials. Procedures for obtaining these are not covered in this standard.

2. REFERENCED DOCUMENTS

2.1 AASHTO Standards

- T88 Particle Size Analysis of Soils
- T89 Determining the Liquid Limit of Soils
- T90 Determining the Plastic Limit and the Plasticity Index of Soils
- T99 Moisture-Density Relations of Soils Using a 2.5 kg (5.5 lb) Rammer and a 305 mm (12 in) Drop
- T100 Specific Gravity of Soils
- T180 Moisture-Density Relations of Soils Using a 4.54 kg (10 lbs) Rammer and a 457 mm (18 in) Drop
- T233 Density of Soil In-Place by Block, Chunk or Core Sampling
- T265 Laboratory Determination of Moisture Content of Soils
- T296 Unconsolidated, Undrained Compressive Strength of Cohesive Soils in Triaxial Compression
- T310 In Place Density and Moisture Content of Soil and Soil-Aggregate by Nuclear Methods (Shallow Depth)

2.2 ASTM Standards

- D1586-99 Standard Test Method for Penetration Test and Split-Barrel Sampling of Soils
- D3441-98 Standard Test Method for Mechanical Cone Penetration Tests of Soil

3. TERMINOLOGY

- 3.1 Unbound Granular Base and Subbase Materials - These include soil-aggregate mixtures and naturally occurring materials. No binding or stabilizing agent is used to prepare unbound granular base or subbase layers. These materials are classified as Type 1 and Type 2, as subsequently defined in Sections 3.3 and 3.4.
- 3.2 Subgrade - Subgrade soils may be naturally occurring or prepared and compacted before the placement of subbase and/or base layers. These materials are classified as Type 1, Type 2, Type 3 and Type 4, as subsequently defined in Sections 3.3, 3.4, 3.5 and 3.6.
- 3.3 Material Type 1 - Includes all unbound granular base and subbase materials and all untreated subgrade soils with maximum particle sizes greater than 9.5 mm (0.375 in). All material greater than 25.4 mm (1.0 in)

shall be scalped off prior to testing. Materials classified as Type 1 shall be molded in either a 152-mm (6-in) diameter mold or a 102-mm (4-in) diameter mold as described in Section 7.1. Materials classified as Type 1 shall be compacted by impact or vibratory compaction.

3.4 Material Type 2 - Includes all unbound granular base and subbase materials and all untreated subgrade soils that have a maximum particle size less than 9.5 mm (0.375 in) and that meet the criteria of less than 10% passing the 75mm (No. 200) sieve. Materials classified as Type 2 shall be molded in a 102-mm (4-in) diameter mold and compacted by vibratory compaction.

3.5 Material Type 3 - Includes all untreated subgrade soils that have a maximum particle size less than 9.5 mm (0.375 in) and that meet the criteria of more than 10% passing the 75mm (No. 200) sieve. Materials classified as Type 3 shall be molded in a 102-mm (4-in) diameter mold and compacted by impact or kneading compaction.

3.6 Material Type 4 - Includes thin-walled tube samples of untreated subgrade soils. Material Type 4 represents undisturbed samples of subgrade soils, tested as 71-mm (2.8 in) diameter specimens.

3.7 Resilient Modulus - The resilient modulus is determined by repeated load compression tests on test specimens of the unbound material. Resilient modulus (M_r) is the ratio of the peak axial repeated deviator stress to the peak recoverable axial strain of the specimen.

3.8 Loading Wave Form - Test specimens are loaded using a haversine load pulse as shown in Figure A-1.

3.9 Maximum Applied Axial Load (P_{max}) - The load applied to the sample consisting of the contact load and cyclic load (confining pressure is not included):

$$P_{max} = P_{contact} + P_{cyclic}$$

3.10 Contact Load ($P_{contact}$) - Vertical load placed on the specimen to maintain a positive contact between the loading ram and the specimen top cap. The contact load includes the weight of the top cap and the static load applied by the ram of the loading system.

3.11 Cyclic Axial Load - Repetitive load applied to a test specimen:

$$P_{cyclic} = P_{max} - P_{contact}$$

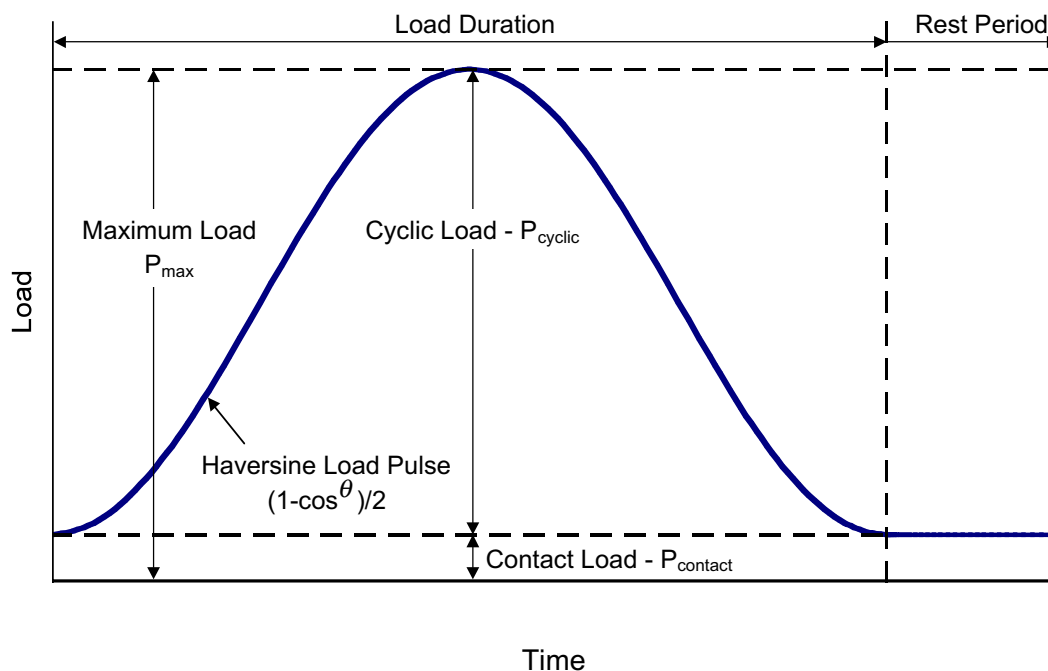

Figure A-1. Definition of Resilient Modulus Terms

- 3.12 Maximum Applied Axial Stress (S_{\max}) - The axial stress applied to the sample consisting of the contact stress and the cyclic stress (the confining stress is not included):

$$S_{\max} = P_{\max} / A$$

Where A = initial cross-sectional area of the sample.

- 3.13 Cyclic Axial Stress - Cyclic (resilient) applied axial stress:

$$S_{\text{cyclic}} = P_{\text{cyclic}} / A$$

- 3.14 Contact Stress (S_{contact}) - Axial stress applied to a test specimen to maintain a positive contact between the specimen cap and the specimen:

$$S_{\text{contact}} = P_{\text{contact}} / A$$

The contact stress shall be maintained so as to apply a constant anisotropic confining stress ratio:

$$(S_{\text{contact}} + S_3) / S_3 = 1.2$$

Where S_3 is the confining pressure.

- 3.15 S_3 is the applied confining pressure in the triaxial chamber (i.e., the minor principal stress σ_3).

- 3.16 ϵ_r is the resilient (recoverable) axial deformation due to S_{cyclic} .

- 3.17 ϵ_r is the resilient (recoverable) axial strain due to S_{cyclic} :

$$\epsilon_r = e_r / L$$

Where L = distance between measurement points for resilient axial deformation, e_r .

- 3.18 Resilient Modulus (M_r) is defined as

$$S_{\text{cyclic}} / \epsilon_r$$

- 3.19 Load duration is the time interval the specimen is subjected to a cyclic stress pulse.

- 3.20 Cycle duration is the time interval between the successive applications of a cyclic stress (usually 1.0 sec.).

4. SUMMARY OF METHOD

- 4.1 A repeated axial stress of fixed magnitude, load duration, and cycle duration is applied to a cylindrical test

specimen. The test is performed in a triaxial cell and the specimen is subjected to a repeated (cyclic) stress and a constant confining stress provided by means of cell air pressure. The total resilient (recoverable) axial deformation response of the specimen is measured and used to calculate the resilient modulus. A flowchart of the method is presented in Figure A-2.

5. SIGNIFICANCE AND USE

- 5.1 The resilient modulus test results provide a basic constitutive relationship between stiffness and stress state of pavement materials for use in pavement design procedures and the structural analysis of layered pavement systems. The resilient modulus test simulates the conditions in a pavement due to application of moving wheel loadings. As a result, the test provides an excellent means for comparing the behavior of pavement construction materials under a variety of conditions (i.e., moisture, density, gradation, etc.) and stress states.

6. RESILIENT MODULUS TEST APPARATUS

- 6.1 Triaxial Pressure Chamber - The pressure chamber is used to contain the test specimen and the confining fluid during the test. A typical triaxial chamber suitable for use in resilient modulus testing of soils is shown in Figure A-3(a). The axial deformation is measured internally, directly on the specimen using an optical extensometer, non-contact sensors, or clamps (Figure A-3). For soft and very soft subgrade specimens (i.e., $S_u < 36$ kPa or 750 psf, where S_u is the undrained shear strength of the soil), clamps should not be used because they may damage the specimen. However, a pair of LVDTs extending between the top and bottom platens can be used to measure axial deformation of these weak soils.

- 6.1.1 Air shall be used in the triaxial chamber as the confining fluid for all testing,

- 6.1.2 The chamber shall be made of polycarbonate, acrylic, or other suitable see-through material. If an optical extensometer is used, the line of sight must pass through a flat face of the chamber. Hence, a standard cylindrical chamber cannot be used with an optical extensometer.

- 6.2 Loading Device - The loading device shall be a top-loading, closed-loop electro-hydraulic testing machine with a function generator which is capable of applying repeated cycles of a haversine-shaped load pulse. Each pulse shall have a 0.1-sec. duration followed by a rest period of 0.9 sec. duration for base/subbase materials and a 0.2-sec. duration followed by a rest period of 0.8

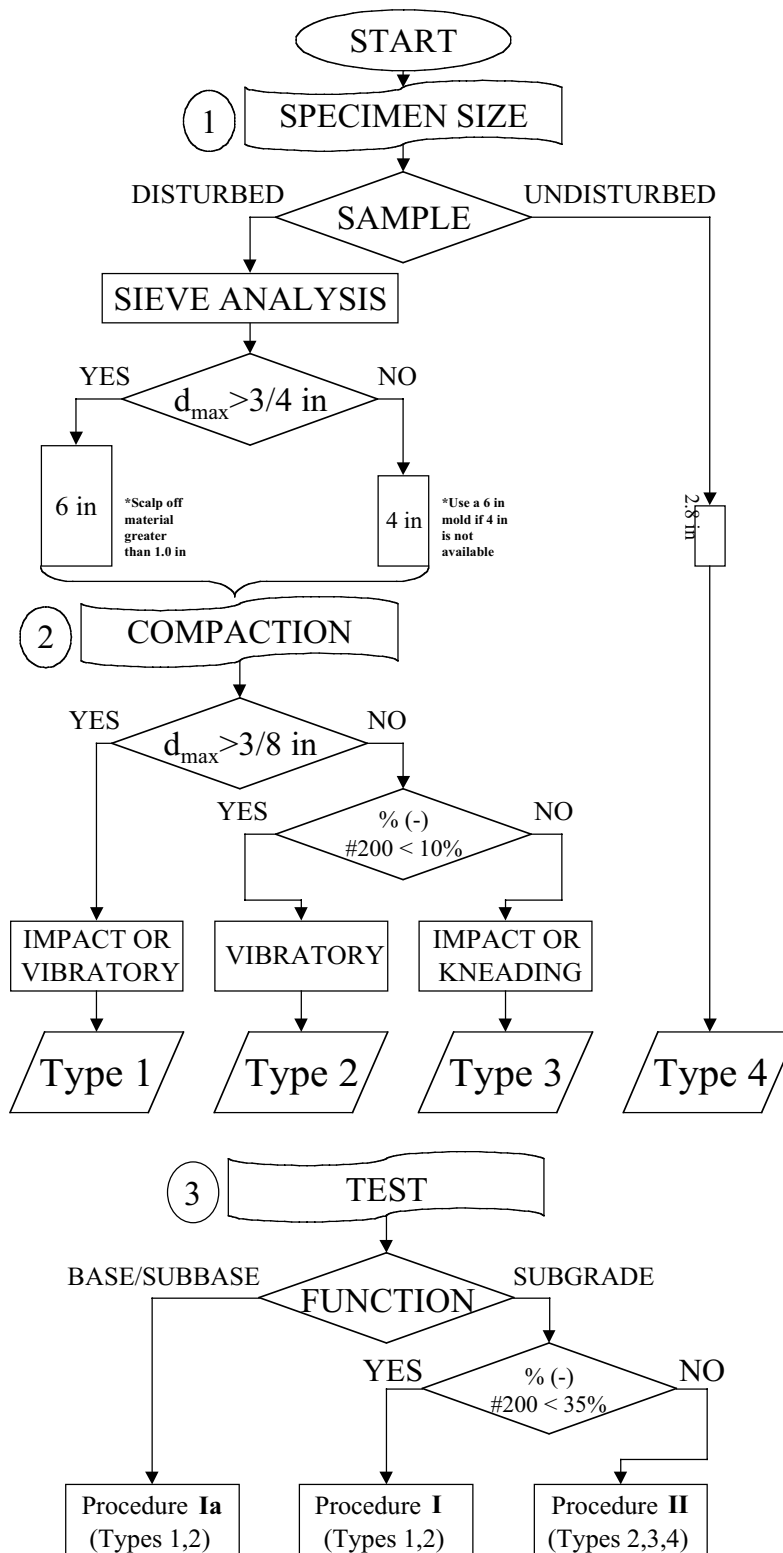
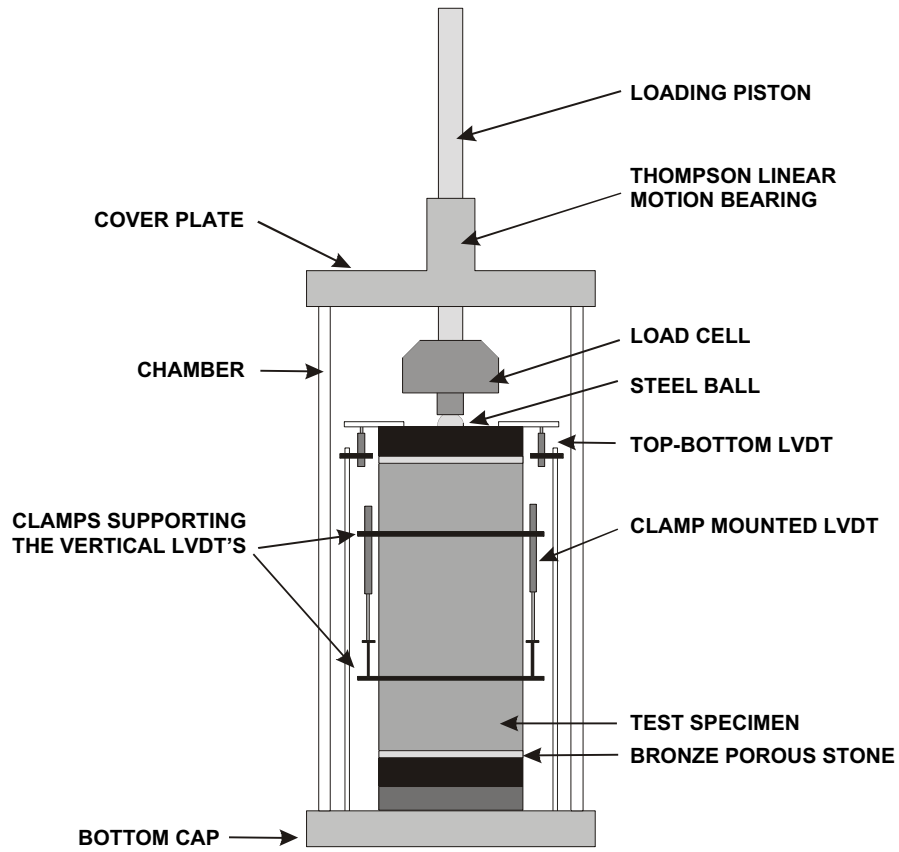
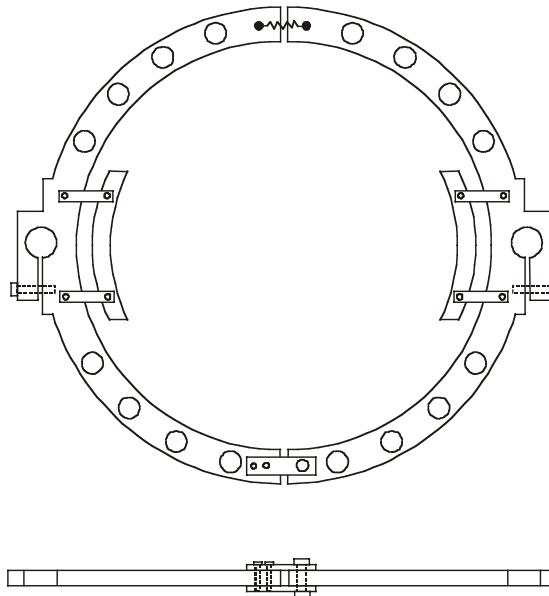

Figure A-2. Test Method Flowchart



a) Triaxial Cell



b) Typical Clamps Used To Measure Axial Deformation

Figure A-3. Triaxial Cell Set-up

sec. duration for subgrade materials. For non-plastic granular materials, it is permissible, if desired, to reduce the rest period to 0.4 sec. to shorten testing time: the loading time may be increased to 0.15 sec. if required.

- 6.2.1 The haversine-shaped load pulse shall conform to Section 3.8 except as noted above. All conditioning and testing shall be conducted using a haversine-shaped load pulse. The electro-hydraulic system-generated haversine waveform and the response waveform shall be displayed to allow the operator to adjust the gains to ensure they coincide during conditioning and testing.

6.3 Load and Specimen Response Measuring Equipment

- 6.3.1 The axial load measuring device should be an electronic load cell located inside the triaxial cell as shown in Figure A-3 (a). The following load cell capacities are required:

Sample Diameter mm (in)	Max. Load Capacity kN (lbs)	Required Accuracy N (lbs)
71 (2.8)	2.2 (500)	+/- 4.5 (+/- 1)
102 (4.0)	8.9 (2000)	+/- 17.8 (+/- 4)
152 (6.0)	22.24 (5000)	+/- 22.24 (+/- 5)

Note 2 – During periods of resilient modulus testing, the load cell shall be monitored and checked once every two weeks or after every fifty resilient modulus tests with a calibrated proving ring to ensure that the load cell is operating properly. An alternative to using a proving ring is to insert an additional calibrated load cell and independently measure the load applied by the original cell. Additionally, the load cell shall be checked at any time there is a suspicion of a load cell problem. Resilient modulus testing shall not be conducted if the testing system is found to be out of calibration.

- 6.3.2 The test chamber pressures shall be monitored with conventional pressure gages, manometers, or pressure transducers accurate to 0.7 kPa (0.1 psi).
- 6.3.3 Axial Deformation: Axial deformation is to be measured on the specimen using one of the following devices: (1) optical extensometer, (2) non-contact sensors, or (3) clamps attached to the specimen. Table A-1 summarizes the specifications for non-contact and clamp measurement devices. Deformation shall be measured over approximately the middle half of the specimen. For Methods 2 or 3 of the above, deformation shall be measured independently on each side of the specimen using gages having the maximum practical sensitivity.

- 6.3.3.1 Optical Extensometer: The optical extensometer should have at least the following minimum requirements: (1) resolution: 0.0002 in; (2) frequency response: 200 Hz bandwidth; (3) linearity: 0.1%; (4) displacement range: 0.5 in; (5) gage length range: 2.5 in to 5.0 in; (6) analog-to-digital output signal. If displacement is measured on a single side of the specimen, two externally or internally mounted LVDTs or dial indicators should be used to determine specimen eccentricity under loading.

- 6.3.3.2 Non-Contact Proximity Sensors: Proximity gages shall have the minimum voltage output given in Table A-1.

- 6.3.3.3 Clamp-Mounted LVDTs: LVDTs shall have the minimum voltage output indicated in Table A-1. A pair of clamp-mounted LVDTs are placed on the specimen at the $1/4$ diameter point (Figure A-3 (b)). Each clamp shall be rigid with the clamp weight not exceeding the following values: 6 in clamp: 2.4 N (0.55 lbs); 4 in clamp: 1.8 N (0.40 lbs); 2.8 in clamp: 1.0 N (0.22 lbs). Minimize clamp weight by drilling small holes in the clamp. Clamp spring force should be as follows: 6 in clamp: 44.5 N (10.0 lbs); 4 in clamp: 33.4 N (7.5 lbs); 2.8 in clamp: 18.2 N (4.1 lbs). Use two pairs of 12-mm (0.5-in) diameter rods, cut to the correct length, to position the clamps in a horizontal plane at the correct location on the specimen.

- 6.3.3.4 Spring-Loaded LVDTs: LVDTs shall be used to maintain a positive contact between the LVDTs and the surface on which the tips of the transducers rest. If the specimen is soft enough to be damaged by clamps or slippage of clamps is suspected, use one of the alternative axial displacement measurement techniques. Slippage of clamps may be a problem for soft and very soft subgrade soils that undergo large deformations. Specimen damage due to clamps and clamp slippage should not be a problem for reasonable quality base and subbase specimens. The two LVDTs, or proximity gages, shall be wired so that each transducer is read, and the results reviewed, independently. The measured displacements shall be averaged for calculating the resilient modulus.

Note 3 – Misalignment or dirt on the shaft of the transducer can cause the shafts of the LVDTs to stick. The laboratory technician shall depress and release each LVDT repeatedly prior to each test to ensure that they move freely and are not sticking. A cleaner/lubricant specified by the manufacturer shall be applied to the transducer shafts regularly.

- 6.3.4 Data Acquisition: An analog-to-digital data acquisition system is required. The overall system should

TABLE A-1
SPECIFICATIONS FOR AXIAL LVDTs AND NON-CONTACT PROXIMITY
DEFORMATION MEASUREMENT INSTRUMENTATION¹

MATERIAL/SPECIMEN SIZE	MIN. RANGE (IN.) (+/-)	APPROX. RESILIENT SPECIMEN DISP. (IN.)	MINIMUM A.C. OUTPUT (MV)	TYPICAL LVDT MIN. SENSITIVITY @ 3V, MV/V/0.001 IN.	TYPICAL PROXIMITY GAUGE MIN. SENSITIVITY (MV/V/0.001 IN.)
AGGREGATE BASE					
6 IN DIA. SPECIMEN	0.25	0.001	6	2.1	-
4 IN DIA. SPECIMEN	0.1	0.00065	5	2.8	5
SUBGRADE SOIL – SAND					
4 IN DIA. SPECIMEN	.25	0.0014	8	2.1	-
2.8 IN DIA. SPECIMEN	.25	0.001	6	2.1	-
SUBGRADE SOIL – COHESIVE, 2.8 IN					
SOFT ²	0.1	0.008	20	1.8	2 – 5.0
FIRM	0.1	0.002	10	2.1	5
STIFF – VERY STIFF ³	0.1	0.0004	3.5	2.8 ⁴	5

NOTES:

1. MINIMUM RESILIENT DISPLACEMENTS, EXCEPT AS NOTED, ARE MEASURED OVER THE CENTRAL ONE-HALF OF A SPECIMEN HAVING A HEIGHT TWICE ITS DIAMETER. CORRECT THIS DISPLACEMENT IF ANOTHER GAUGE LENGTH IS USED. MINIMUM RESILIENT MODULUS DISPLACEMENT IS APPROXIMATE AND VARIES WITH THE MATERIALS TESTED.

2. RESILIENT DISPLACEMENT MEASURED OVER ENTIRE SPECIMEN HEIGHT.

3. CONSIDER USING GROUTED ENDS AND TOP TO BOTTOM LVDTs OR 4.0 IN DIAMETER SPECIMENS BECAUSE OF POTENTIALLY VERY SMALL DISPLACEMENT AT SMALL DEVIATOR STRESSES.

4. PUSH MEASUREMENT SYSTEM TO MAXIMUM OUTPUT: CONSIDER EXCEEDING RECOMMENDED VOLTAGE.

include automatic data reduction to minimize the chance for errors and maximize production. Suitable signal excitation, conditioning, and recording equipment are required for simultaneous recording of axial load and deformations. The system should meet or exceed the following additional requirements: (1) 25 μ s A/D conversion time; (2) 12-bit resolution; (3) single- or multiple-channel throughput (gain = 1), 30 kHz; (4) software selectable gains; (5) measurement accuracy of full scale (gain = 1) of +/- 0.02%; and (6) non-linearity (LSBS) of +/- 0.5%. The signal shall be clean and free of noise (shielded cables properly grounded shall be used). Filtering the output signal during or after data acquisition is discouraged. If a filter is used, it should have a frequency higher than 10 to 20 Hz. A supplemental study should be made to ensure correct peak readings are obtained from filtered data compared with unfiltered data. A minimum of 200 data points from each LVDT shall be recorded per load cycle.

6.4 Specimen Preparation Equipment: A variety of equipment is required to prepare undisturbed samples for testing and to prepare compacted specimens that are representative of field conditions. Use of different materials and different methods of compaction in the field requires the use of varying compaction techniques in the laboratory. Specimen preparation is given in Annex A-1 and specimen compaction equipment and compaction procedures are given in Annexes A-2 (vibratory), A-3 (impact) and A-4 (kneading).

6.5 Equipment for trimming test specimens from undisturbed thin-wall tube samples of subgrade soils shall be as described in AASHTO T 296.

6.6 Miscellaneous Apparatus: This includes calipers, micrometer gauge, steel rule (calibrated to 0.5 mm (0.02 in)), rubber membranes from 0.25 to 0.79 mm (0.02 to 0.031 in) thickness, rubber O-rings, vacuum source with bubble chamber and regulator, membrane

expander, porous stones (subgrade), 6.4-mm (0.25-in) thick porous stones or bronze discs (base/subbase), scales, moisture content cans, and data sheets.

6.7 Periodic System Calibration: The entire system (transducers, signal conditioning and recording devices) shall be calibrated every two weeks or after every fifty resilient modulus tests. Daily and other periodic checks of the system may also be performed as necessary. No resilient modulus testing will be conducted unless the entire system meets the established calibration requirements.

6.7.1 The response of the deformation measurement system shall be checked daily during use. Additionally, the deformation measurement system shall be calibrated every two weeks, or after every fifty resilient modulus tests, whichever comes first. Calibration shall be accomplished using a micrometer with compatible resolution or a set of specifically machined, close tolerance gauge blocks. Resilient modulus testing shall not be conducted if the measurement system does not meet the manufacturer's requirements for accuracy.

7. PREPARATION OF TEST SPECIMENS

7.1 The following guidelines, based on the sieve analysis test results, shall be used to determine the test specimen size:

7.1.1 Use 152-mm (6.0-in) diameter and 305-mm (12-in) high specimens for all materials with maximum particle sizes greater than 19 mm (0.75 in). All material greater than 25.4 mm (1.0 in) shall be scalped off prior to testing.

7.1.2 Use 102-mm (4.0-in) diameter and 204-mm (8.0-in) high specimens for all materials with maximum particle sizes less than 19 mm (0.75 in).

7.2 Undisturbed Subgrade Soil Specimens: Trim and prepare thin-walled tube samples of undisturbed subgrade soil specimens as described in T 234. The natural moisture content (w) of a tube sample shall be determined after triaxial M_r testing following the procedure T 265.

The following procedure shall be used for the thin-walled tube samples:

7.2.1 Standard penetration tests (ASTM D 1586) or cone penetration tests (ASTM D 3441) performed adjacent to thin-walled tube sample locations and elsewhere along the route are encouraged. The results obtained from penetration testing are used to aid in establishing representative subgrade conditions and

in selecting a representative sample for testing. The sample selected should be of acceptable quality, representative of the subgrade conditions near the surface, and preferably taken from the uppermost tube pushed into the subgrade.

7.2.2 To be suitable for testing, a specimen cut from the tube sample must have a length equal to at least twice its diameter after preparation. The sample must be free from defects that would result in unacceptable or biased test results. Such defects include sampling/trimming induced cracks in the specimen, corners broken off that cannot be repaired during preparation, presence of particles much larger than typical for the material (for example + 19.0 mm (+ 0.75 in) stones in a fine-grained soil), the presence of foreign objects not representative of the subgrade such as large roots, wood particles, and organic material, and gouges due to gravel hanging on the edge of the tube.

7.3 Laboratory-Compacted Specimens: Reconstituted test specimens of all types shall be prepared to the specified or in situ dry density (γ_d) and moisture content (w). Laboratory-compacted specimens shall be prepared for all unbound granular base and subbase material and for all subgrade soils for which undisturbed tube specimens could not be obtained.

7.3.1 Moisture Content: For in situ materials, the moisture content of the laboratory-compacted specimen shall be the in situ moisture content for that layer obtained in the field using T 310. If data are not available on in situ moisture content, refer to Section 7.3.3.

7.3.1.1 The moisture content of the laboratory-compacted specimen should not vary from the required value by more than +/- 0.5% for all materials.

7.3.2 Compacted Density: The density of a compacted specimen shall be the in-place dry density obtained in the field for that layer using T 310 or other suitable methods. If these data are not available on in situ density, then refer to Section 7.3.3.

7.3.2.1 The dry density of a laboratory-compacted specimen should not vary more than +/- 1% from the target dry density for that layer.

7.3.3. If either the in situ moisture content or the in-place dry density is not available, then use the optimum moisture content and 95% of the maximum dry density by using T 180 for the base/subbase and 95% of T99 for the subgrade.

7.3.3.1 The moisture content of the laboratory-compacted specimen should not vary from the required value

by more than +/- 0.5% for all materials. The dry density of a laboratory-compacted specimen should not vary more than +/- 1% from the target dry density for that layer.

7.3.4 Sample Reconstitution - Reconstitute the specimen for all materials in accordance with the provisions given in Annex A-1. The target moisture content and density to be used in determining needed material qualities are given in Section 7.3. Annex A-1 provides guidelines to obtain a sufficient amount of material to prepare the appropriate specimen type at the designated moisture content and density. After this step is completed, specimen compaction can begin.

7.4. Compaction Methods and Equipment for Reconstituting Specimens:

7.4.1 Specimens of Type 1 materials shall be compacted by vibratory or impact compaction. The general method of vibratory compaction is given in Annex A-2. The general method of impact compaction is given in Annex A-3.

7.4.3 Specimens of Type 2 materials shall be compacted by vibratory compaction. The general method of vibratory compaction is given in Annex A-2.

7.4.4 Specimens of Type 3 materials shall be compacted by kneading or impact compaction. The general method of kneading compaction is given in Annex A-4. The general method of impact compaction is given in Annex A-3.

8. TEST PROCEDURE

8.1 Initial System Calibration: The testing system, including loading apparatus and triaxial cell, must be calibrated before each major test series; this calibration shall include steps to minimize system compliance and ensure accurate specimen and system alignment and the use of synthetic specimens to establish overall test accuracy.

8.2 Test Methods: Following this test procedure, the resilient modulus test is performed on all materials using a triaxial cell (confined).

8.3. Coarse-Grained Subgrade Soils (Procedure Ib): This procedure is used for all laboratory-compacted specimens of subgrade soils for which the percent passing 75 μm (No. 200) sieve is less than 35%. Reconstructed specimens will usually be compacted directly on the pedestal of the triaxial cell.

8.3.1 Assembly of the Triaxial Chamber: If not already in place, place the specimen with end platens into position on the pedestal of the triaxial cell. If a fixed triaxial cell is used, place the specimen under the axial repeated loading device. Proper positioning of the specimen is extremely critical in applying a concentric load to the specimen. Couple the loading device to the specimen using a smooth steel ball. To center the specimen, slowly rotate the ball as the clearance between the load piston ball decreases and a small amount of load is applied to the specimen. Be sure the ball is concentric with the piston which applies the load (watch the gap around the ball). Shift the specimen laterally to achieve a concentric loading.

8.3.2 Set up the axial displacement measurement system (refer to Section 6.3.3.) and verify that it is working properly.

8.3.3. If a mobile triaxial cell is used, slide the triaxial cell into position under the axial repeated loading device. Positioning of the chamber is extremely critical in applying concentric load to the specimen and minimizing friction forces on the piston rod. Tighten the chamber tie rods firmly to a uniform tension using a torque wrench.

8.3.4 Open all valves on drainage lines leading to the inside of the specimen. This is necessary to develop confining pressure on the specimen.

8.3.5 If not already connected, connect the confining air pressure supply line to the triaxial chamber.

8.3.6 Apply the specified conditioning confining pressure of 27.6 kPa (4.0 psi) to the test specimen. A contact stress equal to 20% of the confining pressure shall be applied to the specimen so that the load piston stays in contact with the top platen at all times.

8.3.7 Conditioning - Begin the test by applying a minimum of 1000 repetitions of a load equivalent to a maximum axial stress of 60.72 kPa (8.8 psi) and a corresponding cyclic stress of 55.2 kPa (8 psi) using a haversine-shaped, 0.2-second load pulse followed by a 0.8-second rest period.

8.3.8 If the vertical permanent strain reaches 5% during conditioning, the conditioning process shall be terminated. A review shall be conducted of the compaction process to identify any reason(s) why the sample did not attain adequate compaction. If this review does not provide an explanation, the material shall be recompacted and tested a second time. If the sample again reaches 5% total vertical permanent strain during preconditioning, then the test shall be

terminated and the appropriate item on the data sheet shall be completed. No further testing of this material is necessary.

8.3.8.1 Conduct appropriate comparative checks of the individual displacement output from the two vertical displacement transducers during the conditioning phase of each M_r test to identify and minimize specimen misalignment. The two measured resilient vertical displacements should have an acceptable vertical displacement ratio. An acceptable displacement ratio (R_v) is defined as $R = Y_{max} / Y_{min}$ less than or equal to 1.10 where Y_{max} equals the largest of the two measured displacements and Y_{min} the smaller value. If unacceptable vertical deformation ratios are obtained, then the test should be discontinued and the specimen alignment difficulties corrected. Very slightly tapping the triaxial cell base in the correct direction or tightening the tension rod nuts on one side of the cell may reduce the eccentricity ratio. Proper equipment alignment is essential. The top of the specimen (and top cap) must be at right angles to the axis of the specimen. Once

acceptable vertical deformation values are obtained, then the test should be continued to completion. Specimen alignment is critical for good M_r results.

8.3.9 Specimen Testing: Perform the resilient modulus test following the load sequence shown in Table A-2 (Procedure Ib – Granular and Low Cohesion Subgrades). Begin by decreasing the maximum axial stress to 9.66 kPa (1.4 psi) (Sequence No. 1 Table A-2) and set the confining pressure to 13.8 kPa (2 psi).

8.3.10 Apply 100 repetitions of the corresponding cyclic axial stress using a haversine-shaped load pulse consisting of a 0.2-second load followed by a 0.8-second rest period. Record the average recovered deformations for each LVDT separately for the last five cycles on Report Form 1.

8.3.11 Increase the maximum axial stress to 19.32 kPa (2.8 psi) and set the confining pressure to 27.6 kPa (4 psi) (Sequence No. 2, Table A-2 and repeat the previous step at this new stress level).

TABLE A-2
PROCEDURE Ib - TEST SEQUENCE FOR GRANULAR SUBGRADES

Procedure Ib (Granular Subgrades)										
Sequence	Confining Pressure		Contact Stress		Cyclic Stress		Maximum Stress		Nrep	
	kPa	psi	kPa	psi	kPa	psi	kPa	psi		
0	27.6	4.0	5.5	0.8	55.2	8.0	60.7	8.8	1000	
1	13.8	2.0	2.8	0.4	6.9	1.0	9.7	1.4	100	
2	27.6	4.0	5.5	0.8	13.8	2.0	19.3	2.8	100	
3	41.4	6.0	8.3	1.2	20.7	3.0	29.0	4.2	100	
4	55.2	8.0	11.0	1.6	27.6	4.0	38.6	5.6	100	
5	82.8	12.0	16.6	2.4	41.4	6.0	58.0	8.4	100	
6	13.8	2.0	2.8	0.4	13.8	2.0	16.6	2.4	100	
7	27.6	4.0	5.5	0.8	27.6	4.0	33.1	4.8	100	
8	41.4	6.0	8.3	1.2	41.4	6.0	49.7	7.2	100	
9	55.2	8.0	11.0	1.6	55.2	8.0	66.2	9.6	100	
10	82.8	12.0	16.6	2.4	82.8	12.0	99.4	14.4	100	
11	13.8	2.0	2.8	0.4	27.6	4.0	30.4	4.4	100	
12	27.6	4.0	5.5	0.8	55.2	8.0	60.7	8.8	100	
13	41.4	6.0	8.3	1.2	82.8	12.0	91.1	13.2	100	
14	55.2	8.0	11.0	1.6	110.4	16.0	121.4	17.6	100	
15	82.8	12.0	16.6	2.4	165.6	24.0	182.2	26.4	100	
16	13.8	2.0	2.8	0.4	41.4	6.0	44.2	6.4	100	
17	27.6	4.0	5.5	0.8	82.8	12.0	88.3	12.8	100	
18	41.4	6.0	8.3	1.2	124.2	18.0	132.5	19.2	100	
19	55.2	8.0	11.0	1.6	165.6	24.0	176.6	25.6	100	
20	82.8	12.0	16.6	2.4	248.4	36.0	265.0	38.4	100	

REPORT FORM 1

1 SAMPLE NUMBER -----

2 SAMPLE DESCRIPTION -----

3 MATERIAL TYPE

4 TEST DATE -----

5 MATERIAL CONSTANTS K1 = K2 = K3 = K6 = K7 =

6 REFERENCE RESILIENT MODULUS ----- Mpa ----- (KSI)

7 RESILIENT MODULUS TESTING:

COLUMN #	1	2	3	4	5	6	7	8	9	10	11	12	13	14
PARAMETER	CHAMBER CONFINING PRESSURE	NOMINAL MAXIMUM AXIAL STRESS	CYCLE NO.	ACTUAL APPLIED MAX. AXIAL LOAD	ACTUAL APPLIED CYCLIC LOAD	ACTUAL APPLIED CONTACT LOAD	ACTUAL APPLIED MAXIMUM AXIAL STRESS	ACTUAL APPLIED CYCLIC STRESS	ACTUAL APPLIED CONTACT STRESS	RECOV. DEF. LVDT #1 READING	RECOV. DEF. LVDT #2 READING	AVERAGE RECOV. DEF. LVDT AND 2	RESILIENT STRAIN	RESILIENT MODULUS
DESIGNATION	S ₃	S _{CYCLIC}		P _{MAX}	P _{CYCLIC}	P _{CONTACT}	S _{MAX}	S _{CYCLIC}	S _{CONTACT}	H ₁	H ₂	H _{AVG}	ε _r	M _R
UNIT	kPa	kPa		N	N	N	kPa	kPa	kPa	mm	mm	mm	mm/mm	MPa
PRECISION	-----	-----	-----	-----	-----	-----	-----	-----	-----	-----	-----	-----	-----	-----
SEQUENCE			1											
			2											
			3											
			4											
			5											
	COLUMN AVERAGE													
	STANDARD DEVIATION													

* REPEAT FOR SEQUENCES 2 THROUGH 30

- 8.3.12 Continue the test for the remaining stress sequences in Table A-2 (i.e., Sequences 3 through 20) recording the vertical recovered deformation. If at any time the total permanent strain of the sample exceeds 5%, stop the test and report the result on the appropriate worksheet.
- 8.3.13 At the completion of the test, reduce the confining pressure to zero and remove the sample from the triaxial chamber.
- 8.3.14 Remove the membrane from the specimen and use the entire specimen to determine moisture content in accordance with T 265.
- 8.4 Cohesive Subgrade Soils (Procedure II): This procedure is used for all laboratory-compacted specimens of subgrade soils for which the percent passing 75 μm (No. 200) sieve is greater than 35% and for all undisturbed specimens of cohesive subgrade soils.
- 8.4.1 Assembly of the triaxial cell: refer to Section 8.3.1
- 8.4.2 Stiff to Very Stiff Specimens: For stiff and very stiff cohesive specimens ($S_u > 36 \text{ kPa}$ (750 psf)), axial deformation should preferably be measured either directly on the specimen or else between the solid end platens using grouted specimen ends. The symbol S_u denotes the undrained shear strength of the soil.
- These stiff to very stiff specimens generally have a resilient modulus greater than 69,000 kPa (10,000 psi). If the specimen ends are not grouted, axial deformation measurement between end platens can still be performed. Following this less reliable approach, however, the measured resilient modulus must be empirically increased to account for the presence of irregular specimen end contacts. The empirical correction factors should be developed for each category of subgrade soil to be tested. To do this, use either specimens with grouted ends and top-to-bottom axial deformation measurement or specimens having axial deformation measurements made directly on them.
- 8.4.3 Soft Specimens: The axial deformation of soft subgrade soils ($S_u < 37.9 \text{ kPa}$ (750 psf)) should not be measured using clamps placed on the specimen. If the measured resilient modulus is less than 69,000 kPa (10,000 psi), axial deformation can be measured between top and bottom platens. An empirical correction is not required for irregular specimen end contacts for these low moduli soils. If the resilient modulus is greater than 69,000 kPa (10,000 psi), follow the procedures given in Section 8.4.2.
- 8.4.4 Specimen End Grouting: All grouted test specimens shall be grouted to the top and bottom end platens using a Hydrostone paste (or equivalent) having a thickness no greater than 3.0 mm (0.12 in). The paste allows adjustment of the level of the top cap and pedestals to accommodate or eliminate any imperfections in the specimen end surfaces. The grout also helps to improve both the uniformity of the applied repeated stress and the accuracy of the deformation measurements of the specimen.
- 8.4.4.1 The grout paste shall be prepared using potable water and Hydrostone cement mixed in a (W/C) ratio of 0.40. Once the water is mixed with the grout, the hydration begins, with consistency rapidly obtained. A minimum of 120 min. is recommended as curing time; this ensures that the grout will be strong enough to withstand the applied stresses in the resilient modulus test without risking the accuracy and reliability of the measurements.
- 8.4.4.2 To expedite this operation, the grouting can be performed on a pedestal frame, similar to the one used in capping concrete cylinders, with additional steel caps that can be bolted to the original end platens. Refer to Annex A-5 for detailed grouting procedures for specimen ends.
- 8.4.5 Install Axial Displacement Devices: Carefully install the axial displacement instrumentation selected under Section 8.4.2 or 8.4.3. For top-to-bottom displacement measurement, attach the LVDTs or proximity gages on steel or aluminum bars extending between the top and bottom platens. If an optical extensometer is to be used, attach the two targets directly to the specimen using at least two small pins for each target. If clamps are used, place clamps at the $1/4$ -diameter points of the specimen using two height gages to ensure that clamps are positioned horizontally at the correct height. Each height gage can consist of two circular aluminum rods machined to the correct length. These rods are placed on each side of the clamp to ensure proper location. Then ensure the displacement instrumentation is working properly by displacing each device and observing the resulting voltage output as shown by the data acquisition system.
- 8.4.6 Refer to Section 8.3.3
- 8.4.7 If not already connected, connect the confining air pressure supply line to the triaxial chamber.
- 8.4.8 Open all valves on drainage lines leading to the inside of the specimen. This is necessary to develop confining pressure on the specimen.

- 8.4.9 Apply the specified conditioning confining pressure of 27.6 kPa (4.0 psi) to the test specimen. A contact stress equal to 20% of the confining pressure shall be applied to the specimen so that the load piston stays in contact with the top platen at all times.
- 8.4.10 Conditioning: Begin the test by applying a minimum of 1000 repetitions of a load equivalent to a maximum axial stress of 53.8 kPa (7.8 psi) and a corresponding cyclic stress of 48.3 kPa (7 psi) using a haversine-shaped, 0.2-second load pulse followed by a 0.8-second rest period.
- 8.4.10.1 If the vertical permanent strain reaches 5% during conditioning, the conditioning process shall be terminated. A review shall be conducted of the compaction process to identify any reason(s) why the sample did not attain adequate compaction. If this review does not provide an explanation, the material shall be recompacted and tested a second time. If the sample again reaches 5% total vertical permanent strain during preconditioning, then the test shall be terminated and the appropriate item on the data sheet shall be completed. No further testing of this material is necessary.
- 8.4.10.2 Eccentricity of Load: Minimizing eccentricity of load to an acceptable level is extremely important in resilient modulus testing. To do this, observe the output from the two independent measurement gages during conditioning. Then satisfy the requirements given in Section 8.3.8.1. An optical extensometer may be used with axial deformation being measured on only one side of the specimen. For this condition, set up two LVDTs or proximity gages between the top and bottom platens.
- 8.4.11 Specimen Testing: Perform the resilient modulus test following the load sequence shown in Table A-3 (Procedure II – Cohesive Subgrades). Begin by decreasing the maximum axial stress to 38.6 kPa (5.6 psi) (Sequence No. 1 Table A-3) and set the confining pressure to 55.2 kPa (8 psi).
- 8.4.12 Apply 100 repetitions of the corresponding cyclic axial stress using a haversine-shaped load pulse consisting of a 0.2-second load followed by a 0.8-second rest period. Record the average recovered deformations for each LVDT separately for the last five cycles on Report Form 1.

TABLE A-3
PROCEDURE II - TEST SEQUENCE FOR FINE-GRAINED SUBGRADES

Procedure II (Cohesive Subgrades)										
Sequence	Confining Pressure		Contact Stress		Cyclic Stress		Maximum Stress		Nrep	
	kPa	psi	kPa	psi	kPa	psi	kPa	psi		
0	27.6	4.0	5.5	0.8	48.3	7.0	53.8	7.8	1000	
1	55.2	8.0	11.0	1.6	27.6	4.0	38.6	5.6	100	
2	41.4	6.0	8.3	1.2	27.6	4.0	35.9	5.2	100	
3	27.6	4.0	5.5	0.8	27.6	4.0	33.1	4.8	100	
4	13.8	2.0	2.8	0.4	27.6	4.0	30.4	4.4	100	
5	55.2	8.0	11.0	1.6	48.3	7.0	59.3	8.6	100	
6	41.4	6.0	8.3	1.2	48.3	7.0	56.6	8.2	100	
7	27.6	4.0	5.5	0.8	48.3	7.0	53.8	7.8	100	
8	13.8	2.0	2.8	0.4	48.3	7.0	51.1	7.4	100	
9	55.2	8.0	11.0	1.6	69.0	10.0	80.0	11.6	100	
10	41.4	6.0	8.3	1.2	69.0	10.0	77.3	11.2	100	
11	27.6	4.0	5.5	0.8	69.0	10.0	74.5	10.8	100	
12	13.8	2.0	2.8	0.4	69.0	10.0	71.8	10.4	100	
13	55.2	8.0	11.0	1.6	96.6	14.0	107.6	15.6	100	
14	41.4	6.0	8.3	1.2	96.6	14.0	104.9	15.2	100	
15	27.6	4.0	5.5	0.8	96.6	14.0	102.1	14.8	100	
16	13.8	2.0	2.8	0.4	96.6	14.0	99.4	14.4	100	

- 8.4.13 Decrease the maximum axial stress to 35.8 kPa (5.2 psi) and set the confining pressure to 41.4 kPa (6 psi) (Sequence No. 2 Table A-3) and repeat the previous step at this new stress level.
- 8.4.14 Continue the test for the remaining stress sequences in Table A-3 (i.e., Sequences 3 through 16) recording the vertical recovered deformation. If, at any time, the total permanent strain of the sample exceeds 5%, stop the test and report the result on the appropriate worksheet.
- 8.4.15 At the completion of the test, reduce the confining pressure to zero and remove the sample from the triaxial chamber.
- 8.4.16 Remove the membrane from the specimen and use the entire specimen to determine moisture content in accordance with T 265.
- 8.5 Base/Subbase Materials (Procedure Ia): The procedure described in this section applies to all unbound granular base and subbase materials.
- 8.5.1 Assembly of the triaxial cell: refer to Section 8.3.1
- 8.5.2 Adjust as required the axial displacement measurement system (refer to Section 6.3.3) load cell and data acquisition system and then verify they are working properly.
- 8.5.3 Refer to Section 8.3.3
- 8.5.3 If not already connected, connect the confining air pressure supply line to the triaxial chamber.
- 8.5.4 Open all valves on drainage lines leading to the inside of the specimen. This is necessary to develop confining pressure on the specimen.
- 8.5.5 Apply the specified conditioning confining pressure of 103.5 kPa (15.0 psi) to the test specimen. A contact stress equal to 20% of the confining pressure shall be applied to the specimen so that the load piston stays in contact with the top platen at all times.
- 8.5.6 Conditioning: Begin the test by applying a minimum of 1000 repetitions of a load equivalent to a maximum axial stress of 227.7 kPa (33 psi) and a corresponding cyclic stress of 207 kPa (30 psi) using a haversine-shaped, 0.1-second load pulse followed by a 0.9-second rest period.
- 8.5.6.1 If the vertical permanent strain reaches 5% during conditioning, the conditioning process shall be terminated. A review shall be conducted of the compaction process to identify any reason(s) why the sample did not attain adequate compaction. If this review does not provide an explanation, the material shall be recompacted and tested a second time. If the sample again reaches 5% total vertical permanent strain during preconditioning, then the test shall be terminated and the appropriate item on the data sheet shall be completed. No further testing of this material is necessary.
- 8.5.6.2 Eccentricity of Load: Minimizing eccentricity of load to an acceptable level is extremely important in resilient modulus testing. To do this, observe the output from the two independent measurement gages during conditioning. Then satisfy the requirements given in Section 8.3.8.1. An optical extensometer may be used with axial deformation being measured on only one side of the specimen. For this condition, set up two LVDTs or proximity gages between the top and bottom platens.
- 8.5.7 Specimen Testing: Perform the resilient modulus test following the load sequence shown in Table A-4 (Procedure Ia – Base/Subbase Materials). Begin by decreasing the maximum axial stress to 14.5 kPa (2.1 psi) (Sequence No. 1 Table A-4) and set the confining pressure to 20.7 kPa (3 psi).
- 8.5.8 Apply 100 repetitions of the corresponding cyclic axial stress using a haversine-shaped load pulse consisting of a 0.1-second load followed by a 0.9-second rest period. Record the average recovered deformations for each LVDT separately for the last five cycles on Report Form 1.
- 8.5.9 Increase the maximum axial stress to 30 kPa (4.2 psi) and the confining pressure to 41.4 kPa (6 psi) (Sequence No. 2 Table A-4) and repeat the previous step at this new stress level.
- 8.5.10 Continue the test for the remaining stress sequences in Table A-4 (i.e., Sequences 3 through 30) recording the vertical recovered deformation. If at any time the total permanent strain of the sample exceeds 5%, stop the test and report the result on the appropriate worksheet.
- 8.5.11 At the completion of the test, reduce the confining pressure to zero and remove the sample from the triaxial chamber.
- 8.5.12 Remove the membrane from the specimen and use the entire specimen to determine moisture content in accordance with T 265.

TABLE A-4
PROCEDURE Ia - TEST SEQUENCE FOR BASE/SUBBASE MATERIALS

Procedure Ia (Base/Subbase Materials)									
Sequence	Confining Pressure		Contact Stress		Cyclic Stress		Maximum Stress		Nrep
	kPa	psi	kPa	psi	kPa	psi	kPa	psi	
0	103.5	15.0	20.7	3.0	207.0	30.0	227.7	33.0	1000
1	20.7	3.0	4.1	0.6	10.4	1.5	14.5	2.1	100
2	41.4	6.0	8.3	1.2	20.7	3.0	29.0	4.2	100
3	69.0	10.0	13.8	2.0	34.5	5.0	48.3	7.0	100
4	103.5	15.0	20.7	3.0	51.8	7.5	72.5	10.5	100
5	138.0	20.0	27.6	4.0	69.0	10.0	96.6	14.0	100
6	20.7	3.0	4.1	0.6	20.7	3.0	24.8	3.6	100
7	41.4	6.0	8.3	1.2	41.4	6.0	49.7	7.2	100
8	69.0	10.0	13.8	2.0	69.0	10.0	82.8	12.0	100
9	103.5	15.0	20.7	3.0	103.5	15.0	124.2	18.0	100
10	138.0	20.0	27.6	4.0	138.0	20.0	165.6	24.0	100
11	20.7	3.0	4.1	0.6	41.4	6.0	45.5	6.6	100
12	41.4	6.0	8.3	1.2	82.8	12.0	91.1	13.2	100
13	69.0	10.0	13.8	2.0	138.0	20.0	151.8	22.0	100
14	103.5	15.0	20.7	3.0	207.0	30.0	227.7	33.0	100
15	138.0	20.0	27.6	4.0	276.0	40.0	303.6	44.0	100
16	20.7	3.0	4.1	0.6	62.1	9.0	66.2	9.6	100
17	41.4	6.0	8.3	1.2	124.2	18.0	132.5	19.2	100
18	69.0	10.0	13.8	2.0	207.0	30.0	220.8	32.0	100
19	103.5	15.0	20.7	3.0	310.5	45.0	331.2	48.0	100
20	138.0	20.0	27.6	4.0	414.0	60.0	441.6	64.0	100
21	20.7	3.0	4.1	0.6	103.5	15.0	107.6	15.6	100
22	41.4	6.0	8.3	1.2	207.0	30.0	215.3	31.2	100
23	69.0	10.0	13.8	2.0	345.0	50.0	358.8	52.0	100
24	103.5	15.0	20.7	3.0	517.5	75.0	538.2	78.0	100
25	138.0	20.0	27.6	4.0	690.0	100.0	717.6	104.0	100
26	20.7	3.0	4.1	0.6	144.9	21.0	149.0	21.6	100
27	41.4	6.0	8.3	1.2	289.8	42.0	298.1	43.2	100
28	69.0	10.0	13.8	2.0	483.0	70.0	496.8	72.0	100
29	103.5	15.0	20.7	3.0	724.5	105.0	745.2	108.0	100
30	138.0	20.0	27.6	4.0	966.0	140.0	993.6	144.0	100

9. CALCULATIONS

9.1 Perform the calculations to obtain resilient modulus values using the tabular arrangement similar to that shown on Report Form 1. As indicated on the worksheet, the resilient modulus is computed for each of the last five cycles of each load sequence and then averaged. The data acquisition and data reduction processes should be fully automated to minimize the chance for human error.

9.2 Fit using nonlinear regression techniques the following resilient modulus model to the data obtained from the applied procedure (Table A-2 or Table A-3 or Table A-4)

Equation for normalized log-log k_1, k_2, k_3, k_6, k_7 model:

$$M_R = k_1 \cdot p_a \cdot \left(\frac{\theta - 3k_6}{p_a} \right)^{k_2} \cdot \left(\frac{\tau_{oct} + k_7}{p_a} \right)^{k_3}$$

$$k_1, k_2 \geq 0$$

$$k_3, k_6 \leq 0$$

$$k_7 \geq 1$$

(1)

where

M_R = Resilient Modulus

θ = Bulk Stress:

$$\theta = \sigma_1 + \sigma_2 + \sigma_3$$

τ_{oct} = Octahedral Shear Stress:

$$\tau_{oct} = \frac{1}{3} \cdot \sqrt{(\sigma_1 - \sigma_2)^2 + (\sigma_1 - \sigma_3)^2 + (\sigma_2 - \sigma_3)^2}$$

$\sigma_1, \sigma_2, \sigma_3$ = Principal Stresses

k_i = regression constants

p_a = atmospheric pressure (14.7 psi)

Assign initial values of zero for k_6 and one for k_7 ; Restrain all regression constants according to the model. Report the constants k_1, k_2, k_3, k_6 and k_7 , the ratio of the standard error of estimate to the standard deviation, and the square of the correlation coefficient on Report Form 1.

10. REPORT

- 10.1 The resilient modulus test report should contain the following:
- 10.1.1 Hard copy of Report Form 1: The acquisition system data used to generate this report, as well as the report, shall be stored on a computer diskette in ASCII format.
- 10.1.2 Report Form 2 (recompacted specimens) or Report Form 3 (thin-walled tube specimens).
- 10.2 The following general information is to be recorded on all the Report Forms:
- 10.2.1 The specimen identification, the material type (Type 1, 2, 3, or 4), and test date.
- 10.3 Report the following information on the appropriate data sheet:
- 10.3.1 Report Form 2 shall be used to record general information concerning the specimen being tested. This form shall be completed only for those specimens that are recompacted from bulk samples. This form shall not be used to record information for thin-walled tube samples.
- 10.3.1.1 Item 4: Record a “Y” (Yes) or “N” (No) to denote whether the sample reached 5% total vertical permanent strain during the testing sequence. Record the number of test sequences completed, either partially or completely, for the given sample.
- 10.3.1.2 Item 5: Record the specimen dimensions and perform the area and volume calculations.
- 10.3.1.3 Item 6: Record the compaction masses as outlined in the compaction annexes.
- 10.3.1.4 Item 7: Record the in situ moisture content/density values used as the basis for compaction of the specimen per Sections 7.3.1. and 7.3.2. These values were obtained from nuclear methods in the field. If these values are not available, record the optimum moisture content, maximum dry density, and 95% maximum dry density values used as the basis for compaction of the specimen per Section 7.3.3.
- 10.3.1.5 Item 8: Record the moisture content of the compacted material. Record the moisture content of the material after the resilient modulus test per Section 8.3.14 (Coarse Grained Subgrade), Section 8.4.16 (Fine Grained Subgrade), or Section 8.5.12 (Base/Subbase). Also, record the target density used for specimen recompaction.
- 10.3.2 Report Form 3 shall be used to record general information concerning the specimen being tested. This form shall be completed only for thin-walled tube specimens. This form shall not be used to record information for recompacted samples.
- 10.3.2.1 Item 4: Record the approximate distance from the top of the subgrade to the top of the specimen (if known).
- 10.3.2.2 Item 5: Record a “Y” (Yes) or “N” (No) to denote whether the sample reached 5% total vertical permanent strain during the conditioning stage of the test procedure. Also note with a “Y” (Yes) or “N” (No) whether or not the sample reached 5% total vertical permanent strain during the testing sequence. Record the number of test sequences completed, either partially or completely, for the given sample.
- 10.3.2.3 Item 6: Record the specimen dimensions and perform the area and volume calculations. Record the mass of the specimen.
- 10.3.2.4 Item 7: Record the moisture content (in situ) prior to resilient modulus testing. Record the moisture content at the completion of the resilient modulus testing; per Section 8.3.14, record the wet and dry density of the thin-walled tube sample.
- 10.3.3 Record the test data for each specimen in a format similar to Report Form 1 and attach with Report Form 2 or Report Form 3. The following information shall be recorded on Report Form 1
- 10.3.3.1 Column 1: Record the chamber confining pressure for the testing sequence. Only one entry need be made for the last five load cycles. This entry should correspond exactly with the confining pressure levels shown in Tables A-2, A-3, or A-4.

REPORT FORM 2 - LABORATORY COMPACTED SAMPLES

1 SAMPLING DATE - . - . - . - . - .

2 SAMPLE NUMBER

3 MATERIAL TYPE (1,2,3 OR 4)

4 TEST INFORMATION

PRECONDITIONING - GREATER THAN 5% PERMANENT STRAIN ? (Y/N)

TESTING - GREATER THAN 5% PERMANENT STRAIN ? (Y/N)

TESTING - NUMBER OF LOAD SEIQUENCES COMPLETED (1-30)

5 SPECIMEN INFO

DIAMETER, mm - . - . - .

TOP - . - . - .

MIDDLE - . - . - .

BOTTOM - . - . - .

AVERAGE - . - . - .

MEMBRANE THICKNESS (1) mm - . - . - .

MEMBRANE THICKNESS (2) mm - . - . - .

NET DIAMETER, mm - . - . - .

HEIGHT OF SPECIMEN CAP AND BASE, mm - . - . - .

HEIGHT OF CAP AND BASE, mm - . - . - .

INITIAL LENGTH, L_0 , mm - . - . - .

INITIAL AREA, A_0 , mm^2 - . - . - .

INITIAL VOLUME, A_0L_0 , mm^3 - . - . - .

6 SOIL SPECIMEN WEIGHT

INITIAL WEIGHT OF CONTAINER AND WET SOIL, grams - . - . - . - . - .

FINAL WEIGHT OF CONTAINER AND WET SOIL, grams - . - . - . - . - .

WEIGHT OF WET SOIL USED, grams - . - . - . - . - .

7 SOIL PROPERTIES

IN SITU MOISTURE CONTENT (NUCLEAR), % - . - . - .

IN SITU WET DENSITY (NUCLEAR), % - . - . - . - . - .

OR

OPTIMUM MOISTURE CONTENT, % - . - . - .

MAXIMUM DRY DENSITY, kg/m^3 - . - . - . - . - .

95 % MAXIMUM DRY DENSITY, kg/m^3 - . - . - . - . - .

8 SPECIMEN PROPERTIES

COMPACTION MOISTURE CONTENT, % - . - . - .

MOISTURE CONTENT AFTER RESILIENT MODULUS TESTING, % - . - . - .

COMPACTION DRY DENSITY, γ_d , kg/m^3 - . - . - . - . - .

9 TEST DATE - . - . - . - . - .

10 GENERAL REMARKS

TESTED BY _____

DATE _____

REPORT FORM 3 - THIN-WALLED TUBE SAMPLES**1 SAMPLING DATE** -----**2 SAMPLE NUMBER** **3 MATERIAL TYPE (1,2,3 OR 4)** **4 APPROX. DISTANCE FROM TOP OF SUBGRADE TO SAMPLE, m** -----**5 TEST INFORMATION**PRECONDITIONING - GREATER THAN 5% PERMANENT STRAIN ? (Y/N) TESTING - GREATER THAN 5% PERMANENT STRAIN ? (Y/N) TESTING - NUMBER OF LOAD SEIQUENCES COMPLETED (1-30) **6 SPECIMEN INFO**

DIAMETER, mm -----

TOP -----

MIDDLE -----

BOTTOM -----

AVERAGE -----

MEMBRANE THICKNESS (1) mm -----

MEMBRANE THICKNESS (2) mm -----

NET DIAMETER, mm -----

HEIGHT OF SPECIMEN CAP AND BASE, mm -----

HEIGHT OF CAP AND BASE, mm -----

INITIAL LENGTH, L_0 , mm -----INITIAL AREA, A_0 , mm² -----INITIAL VOLUME, A_0L_0 , mm³ -----

INITIAL WEIGHT, grams -----

7 SOIL PROPERTIES

IN SITU MOISTURE CONTENT, % -----

MOISTURE CONTENT AFTER RESILIENT MODULUS TESTING, % -----

WET DENSITY, γ_w , kg/m³ -----DRY DENSITY, γ_d , kg/m³ -----**8 TEST DATE** -----**9 GENERAL REMARKS**

TESTED BY _____

DATE _____

- 10.3.3.2 Column 2: Record the nominal axial cyclic stress for the testing sequence. Only one entry need be made for the last five load cycles. This entry should correspond exactly with the nominal axial cyclic stress required in Tables A-2, A-3, or A-4.
- 10.3.3.3 Columns 4 through 9: Record the actual applied loads and stresses for each of the last five load cycles as shown on the worksheet.
- 10.3.3.4 Columns 10 through 12: Record the recoverable axial deformation of the sample for each LVDT independently for each of the last five load cycles. Average the responses from the two LVDTs and record this value in Column 12. This value will be used to calculate the axial strain of the material.
- 10.3.3.5 Column 13: Compute the axial strain for each of the last five load cycles. This value is computed by dividing Column 12 by the initial distance between clamps, L_0 .
- 10.3.3.6 Column 14: Compute the resilient modulus for each of the last five load cycles. This value is computed by dividing Column 8 by Column 13.

10.3.3.7 Average: Compute the average of the last five load cycles for each column.

10.3.3.8 Standard Deviation: Compute the standard deviation of the values for each column for the last five load cycles using the equation:

$$s = \sqrt{\frac{\sum (x_i - \bar{x})^2}{n - 1}}$$

10.3.3.9 Summary Resilient Modulus: Calculate and report on Report Form 1 a summary resilient modulus (M_R) using Equation 1 described in Section 9.2. For aggregate base/subbase materials, calculate and report on this form the resilient modulus using the above equation for $S_3 = 35$ kPa (5 psi) and $S_{\text{cyclic}} = 103$ kPa (15 psi). For subgrade soils calculate and report the resilient modulus using the same equation for $S_3 = 14$ kPa (2 psi) and $S_{\text{cyclic}} = 41$ kPa (6 psi).

ANNEX A-1 SAMPLE PREPARATION (MANDATORY INFORMATION)

1. SCOPE

1.1 The following provides guidelines for reconstituting the material to be tested so as to produce a sufficient amount of material needed to prepare the appropriate sample type (Type 1, 2, or 3) at the designated moisture content and density.

2. PREPARATION FOR COMPACTION

2.1 Sample Conditioning – If the sample is damp when received from the field, dry it until it becomes friable. Drying may be in air or by use of a drying apparatus such that the temperature does not exceed 60°C (140°F). Then thoroughly break up the aggregations in such manner as to avoid reducing the natural size of individual particles. Moderate pressure using a rubber-covered implement to push the particles through a 4.75 mm (No. 4) sieve.

2.2 Sample Preparation – Determine the moisture content (w_1) of the sample per T265. The mass of the sample for moisture determination shall not weigh less than 200 g for samples with a maximum particle size smaller than the 4.75 mm (No. 4) sieve and not less than 500 g for samples with a maximum particle size greater than 4.75 mm (No. 4) sieve.

2.2.1 Determine the appropriate total volume (V) of the compacted specimen to be prepared. The total volume must be based on a height of the compacted specimen slightly greater than that required for resilient testing to allow for trimming of the specimen ends if necessary. Compacting to a height/diameter ratio of 2.1 to 2.2 will provide adequate material for this purpose.

2.2.2 Determine the mass of oven-dry soil solids (W_s) required to obtain the desired dry density (γ_d) and moisture content (w) as follows:

$$W_s = 453.59 \gamma_d V$$

where

W_s = Mass of oven-dry solids, g,

γ_d = Desired dry density, lb/ft³

V = Total volume of compacted specimen, ft³.

2.2.3 Determine the mass of the dried sample, (W_{ad}), with the moisture content (w_1) required to obtain W_s plus an additional amount W_{as} of at least 500 grams to provide material for the determination of moisture content at the time of compaction.

$$W_{ad} = (W_s + W_{as})(1 + w_1/100)$$

where

W_{ad} = Mass of sample at water content w_1 , g,

W_{as} = Mass of moisture content specimen (usually 500g), g,

w_1 = Water content of prepared material, %.

2.2.4 Determine the mass of water (W_{aw}) required to change the water content from the existing water content, w_1 , to the desired compaction water content, w.

$$W_{aw} = (W_s + W_{as})[(w - w_1)/100]$$

where

W_{aw} = Mass of water needed to obtain water content w, g,

w = Desired water content of compacted material, %.

2.2.5 Place a sample of mass, W_{ad} , into a mixing pan.

2.2.6 Add the mass of water (W_{aw}), needed to change the water content from w_1 to w, to the sample in small amounts and mix thoroughly after each addition.

2.2.7 Place the mixture into a plastic bag. Seal the bag, place it in a second bag and seal it. Cure the sample for 16 to 48 hours, determine the mass of the wet soil and container to the nearest gram, and record this value on Report Form 2.

2.2.8 The material is now ready for compaction.

2.3 Compaction

2.3.1 Refer to Annexes A-2, A-3, and A-4 for vibratory, impact, and kneading compaction methods.

2.3.2 When the compaction process is complete, carefully open the mold and retrieve the specimen. Record the mass and the dimensions of the specimen on Report Form 2 or 3, as appropriate.

2.3.3 Coarse-grained subgrade specimens should be protected from moisture change by immediately applying the triaxial membrane and testing within 1 day of preparation unless saturation, drying, or curing of the specimen is to be carried out.

2.3.4 Store fine-grained subgrade compacted specimens wrapped in impermeable material and placed in a sealed container, for 1 day in a moisture room before testing.

3. PREPARE THE SPECIMEN FOR TESTING

3.1 Place presoaked porous stones no more than 6.25 mm (0.25 in) thick on both the base and the top of the specimen. If clogging of the porous stones is found to be a problem, presoaked filter paper cut to size can be used between the porous stone and the specimen.

3.2 Place vacuum grease on the sides of the end platens to facilitate a good seal between the membranes and end platens.

- 3.3 Carefully place the specimen on the porous stone/base. Place the membrane on a membrane stretcher, apply a vacuum to the stretcher, then carefully place the membrane on the sample and add the top platen. Remove the membrane from the stretcher, cut off the vacuum and remove the membrane stretcher. Seal the membrane to the top and bottom platens with rubber O rings. A second membrane can be added if puncturing of the membrane is a problem due to the presence of sharp aggregate.
- 3.4 Test for Leaks: Connect the specimen's bottom drainage line to the vacuum source through the medium of a bubble chamber. Apply a vacuum of 35 kPa (5 psi). If

bubbles are present, check for leakage caused by poor connections, holes in the membrane, or imperfect seals at the cap and base. The existence of an airtight seal ensures that the membrane will remain firmly in contact with the specimen. Leakage through holes in the membrane can frequently be eliminated by coating the surface of the membrane with liquid rubber latex or by using a second membrane. When leakage has been eliminated, disconnect the vacuum supply line. Carefully clean the O-rings/gaskets used to seal the chamber; also clean all surfaces that the O-rings will contact.

- 3.5 The specimen is now ready for testing.

ANNEX A-2 VIBRATORY COMPACTION

1. SCOPE

- 1.1 This method covers vibratory compaction procedures for use in resilient modulus testing of materials Type 1 and Type 2.
- 1.2 Split molds with an inside diameter of 152.4 mm (6 in) shall be used to prepare 305-mm (12-in) high test samples for all materials Type 1 or Type 2 having the maximum particle size (d_{max}) greater than 19 mm ($3/4$ in). All material greater than 25.4 mm (1 in) shall be scalped off prior to testing. Split molds with an inside diameter of 101.6 mm (4 in) shall be used to prepare 203.2-mm (8-in) high test samples for all materials Type 1 or Type 2 having the maximum particle size (d_{max}) less than 19 mm ($3/4$ in).
- 1.3 All specimens shall be compacted in 6 lifts in a split mold mounted on the base of the triaxial cell as shown in Figure A-2-1. Compaction forces are generated by a vibratory impact hammer without kneading action powered by air or electricity and of sufficient size to provide the required laboratory densities while minimizing particle breakage and damage to the sample membrane. Use a special compaction head on the final lift to ensure proper specimen alignment (Figure A-2-1 (b)).

2. APPARATUS

- 2.1 A split mold, with an inside diameter of 152 mm (6 in) having a minimum height of 381 mm (15 in) (or a sufficient height to allow guidance of the compaction head for the final lift) shall be used for all materials having the maximum particle size (d_{max}) greater than 19 mm ($3/4$ in). For materials having the maximum particle size (d_{max}) less than 19 mm ($3/4$ in), a split mold with an inside diameter of 101.6 mm (4 in) and a minimum height of 254 mm (10 in) may be used.
- 2.2 Vibratory Compaction Device – Vibratory compaction shall be provided using electric rotary or demolition hammers with a rated input of 750 to 1200 watts and capable of 1800 to 3000 blows per minute.
- 2.3 The compactor head shall be at least 25 mm (1 in) thick and have a diameter of not less than 146 mm (5.75 in) for the 6-in-diameter sample and 97 mm (3.83 in) for the 4-in-diameter sample.

3. PROCEDURE

- 3.1 For removable platens, tighten the bottom platen into place on the triaxial cell base. It is essential that an airtight seal is obtained and that the bottom platen interface with the cell constitutes a rigid joint.

- 3.2 Place the two porous stones and the top platen on the bottom platen. Determine the total height of the top and bottom platens and stones to the nearest 0.25 mm (0.01 in).
- 3.3 Remove the top platen and porous disc if used. Measure the thickness of the rubber membrane with a micrometer.
- 3.4 Place the rubber membrane over the bottom platen and lower porous disc. Secure the membrane to the bottom platen using an O-ring or other means to obtain an airtight seal.
- 3.5 Place the split mold around the bottom platen and draw the membrane up through the mold. Tighten the split mold firmly in place. Exercise care to avoid pinching the membrane. During equipment calibration, ensure by indexing with a dial indicator that the top of the mold is parallel to the base of the triaxial cell.
- 3.6 Stretch the membrane tightly over the rim of the mold. Apply a vacuum to the mold sufficient to draw the membrane in contact with the mold. If wrinkles are present in the membrane, release the vacuum, adjust the membrane and reapply the vacuum. The use of a porous plastic forming jacket liner helps to ensure that the membrane fits smoothly inside the mold. The vacuum is maintained throughout the compaction procedure.
- 3.7 Measure to the nearest 0.25 mm (0.01 in) the inside diameter of the membrane-lined mold and the distance between the top of the lower porous stone and the top of the mold.
- 3.8 Determine the volume, V , of the specimen to be prepared using the diameter determined in Step 3.7 and an assumed value of height between 305 and 318 mm (12 and 12.5 in) for 152-mm (6-in) diameter specimens and between 203 and 216 mm (8 to 8.5 in) for 102-mm (4-in) diameter specimens.
- 3.9 Determine the mass of material, at the prepared water content, to be compacted into the volume (V), to obtain the desired density.
- 3.10 For 152-mm (6-in) diameter specimens (specimen height of 305 mm (12 in)) 6 layers of 2 in per layer are required; for 102-mm (4-in) diameter specimens 6 layers of 33.9 mm (1.33 in) per layer shall be used. Determine the weight of the wet soil, W_L , required for each layer.

$$W_L = W_t/6$$

where

W_t = total weight of the specimen to produce appropriate density.

- 3.11 Place the total required weight of soil for all lifts, W_{ad} , into a mixing pan. Add the required amount of water, W_{aw} , and mix thoroughly.
- 3.12 Determine the weight of the wet soil and the mixing pan.

- 3.13 Place the required amount of wet soil (W_L) into the mold. Avoid spillage. Using a spatula, draw soil away from the inside edge of the mold to form a small mound at the center.
- 3.14 Insert the vibrator head and vibrate the soil until the distance from the surface of the compacted layer to the rim of the mold is equal to the distance measured in Step 3.7 minus the thickness of the layered selected in Step 3.10. This may require removal and reinsertion of the vibrator several times until the experience is gained in gauging the vibration time, which is re-

quired. Use a small circular spirit level to assist in keeping each layer level.

- 3.15 Repeat Steps 3.13 and 3.14 for each new layer after first scarifying the top surface of the previous layer to a depth of about 6.4 mm (1/4 in). The measured distance from the surface of the compacted layer to the rim of the mold is successively reduced by the layer thickness. The final surface should be a smooth plane parallel to the base of the triaxial cell. Use the special compaction head shown in Figure A-2-1 (b) for the final lift. As a final step, the top plate shall be placed

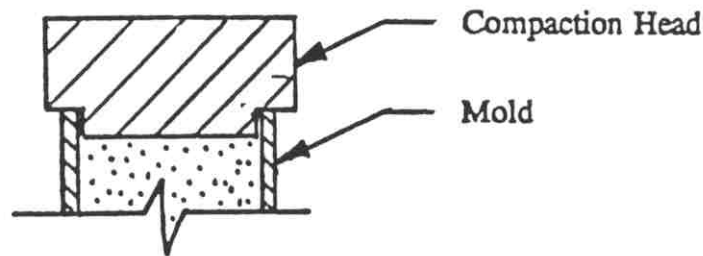

(b) Recommended head for final compaction

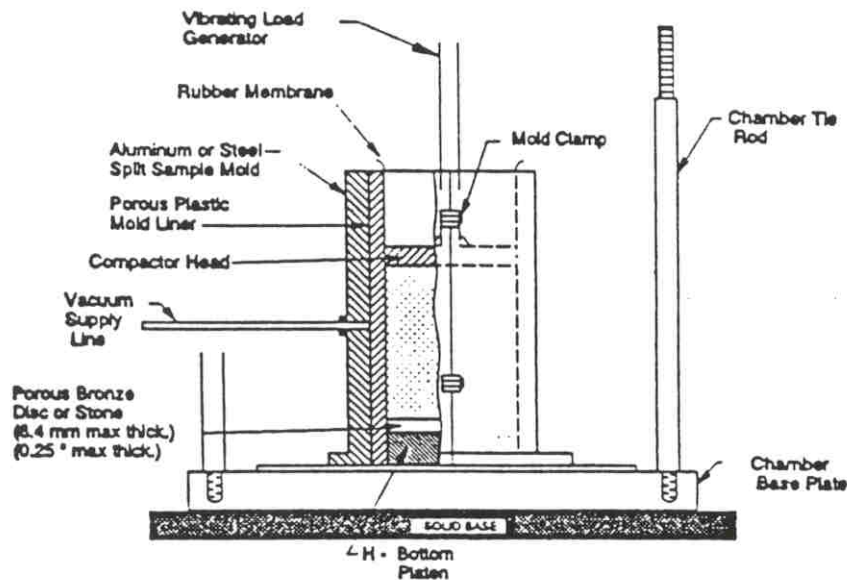

(a) Compaction Mold Assembly

Fig. A-2-1. Typical Apparatus for Vibratory Compaction

on the sample and seated firmly by vibrating with the compactor for about 10 seconds. If necessary, because of degradation of the first membrane, a second membrane can be applied to the sample at the conclusion of the compaction process.

- 3.16 When the compaction process is completed, determine the mass of the mixing pan and the excess soil. This mass subtracted from the mass determined in Step 3.12 is the mass of the wet soil used (mass of the specimen). Verify the compaction water, W_c , of the excess

soil using care in covering the pan of wetted soil during compaction to avoid drying and loss of moisture. The moisture content of this sample shall be conducted using T 265.

- Note 1 – As an alternative for soils lacking in cohesion, a mold with a membrane installed and held by vacuum may be used.
- 3.17 Store or prepare the specimen for testing according to Annex 1.

ANNEX A-3 IMPACT COMPACTION

1. SCOPE

1.1 This test method covers impact compaction procedures for use in resilient modulus testing. Materials are compacted in a 4 or 6 in. (101.6 or 152.4 mm) diameter mold with a 5.5 lbf (24.4 N) rammer dropped from a height of 12 in. (305 mm) producing a compactive (standard) effort of 12,400 ft-lbf/ft³ (600 kN-m/m³), or, with a 10 lbf (44.5 N) rammer, dropped from a height of 18 in. (457 mm) producing a compactive effort (modified) of 56,000 ft-lbf/ft³ (2700 kN-m/m³)

Note 1 – The method is adapted from ASTM Designations D 698-91 and D 1557-91.

1.2 This test method applies only to soils of Type 1 or Type 3.

Note 2 – For materials Type 3 with a high PI, kneading compaction is preferred.

1.3 Two alternative procedures are provided depending on the maximum particle diameter (d_{max}) of the material.

1.3.1 Procedure A:

1.3.1.1 *Mold* – 4 in. (101.6 mm) diameter, 8 in. (203.2 mm) height.

1.3.1.2 *Material* – Passing $3/4$ in. (19.0 mm) sieve.

1.3.1.3 *Layers* – Eight

1.3.1.4 *Blows per layer* – Estimate using Equation 1 (see Section 10.2.3). Increase or decrease the number of blows/layer until the desired density is achieved.

1.3.2 Procedure B:

1.3.2.1 *Mold* – 6 in. (152.4 mm) diameter, 12 in (304.8 mm) height.

1.3.2.2 *Material* – Having a maximum particle diameter (d_{max}) greater than $3/4$ in. (19.0 mm) sieve.

1.3.2.3 *Layers* – Six

1.3.2.4 *Blows per layer* – Estimate using Equation 1. Increase or decrease the number of blows/layer until the desired density is achieved.

1.4 All material greater than 1 in. (25.4 mm) shall be scalped off prior to compacting. If more than 5% by weight oversize fraction (coarse fraction) will not be included in the test, corrections must be made to the unit weight and water content of the specimen or to the appropriate field in place density test specimen using Practice D 4718.

1.5 The values in inch-pound units are to be regarded as the standard. The values stated in SI units are provided for information only.

1.5.1 In the engineering profession it is customary practice to use, interchangeably, units representing both mass and force, unless dynamic calculations ($F = Ma$) are involved. This implicitly combines two separate sys-

tems of units, that is, the absolute system and the gravimetric system. It is scientifically undesirable to combine the use of two separate systems of units within a single standard. This test method has been written using inch-pound units (gravimetric system) where the pound (lbf) represents a unit of force. The use of mass (lbm) is for convenience of units and is not intended to convey the use is scientifically correct. Conversions are given in the SI system in accordance with Practice E 380. The use of balances or scales recording pounds of mass (lbm), or the recording of density in lbm/ft³ should not be regarded as nonconformance with this standard.

1.6 This standard does not purport to address all of the safety concerns, if any, associated with its use. It is the responsibility of the user of this standard to establish appropriate safety and health practices and determine the applicability of regulatory limitations prior to use.

2. REFERENCED DOCUMENTS

2.1 ASTM Standards:

- D 698 Standard Test Method for Laboratory Compaction Characteristics of Soils Using Standard Effort (12,400 ft-lbf/ft³ (600 kN-m/m³))
- D 1557 Test Method for Laboratory Compaction Characteristics of Soil Using Modified Effort (56,000 ft-lbf/ft³ (2700 kN-m/m³))
- C 127 Test Method for Specific Gravity and Absorption of Coarse Aggregate
- C 136 Method for Sieve Analysis of Fine and Coarse Aggregate
- D 422 Test Method for Particle Size Analysis of Soils
- D 653 Terminology Relating to Oil, Rock and Contained Fluids
- D 854 Test Method for Specific Gravity of Soils
- D1557 Test Methods for Moisture-Density Relations of Soils and Soil Aggregate Mixtures using 10 lb (4.54 kg) Rammer and 18 in. (457 mm) Drop
- D 2168 Test Methods for Calibration of Laboratory Mechanical-Rammer Soil Compactors
- D 2216 Test Method for Laboratory Determination of Water (Moisture) Content of Soil, Rock and Soil-Aggregate Mixtures
- D 2487 Test Method for Classification of Soil for Engineering Purposes
- D 2488 Practice for Description of Soils (Visual-Manual Procedure)
- D 4220 Practices for Preserving and Transporting Soil Samples
- D 4253 Test Methods for Maximum Index Density of Soils Using a Vibratory Table
- D 4718 Practice for Correction of Unit Weight and Water Content for Soils Containing Oversize Particles
- D 4753 Specification for Evaluating, Selecting and Specifying

fyng Balances and Scales for Use in Soil and Rock Testing.

- E 1 Specification for ASTM Thermometers
- E 11 Specification for Wire-Cloth Sieves for Testing Purposes
- E 319 Practice for Evaluation of Single-Pan Mechanical Balances
- E 380 Practice for Use of the International System of Units (SI) (the Modernized Metric System)

3. TERMINOLOGY

- 3.1 *Definitions:* See Terminology D 653 for general definitions.
- 3.2 *Description of Terms Specific to This Standard:*
 - 3.2.1 *Oversize Fraction (Coarse Fraction), P_c in %* - the portion of total sample not used in performing the compaction test; it is the portion of total sample retained on the 1.5 in. (38.1 mm) sieve.
 - 3.2.2 *Standard Effort* – the term for the 12,400 ft-lbf/ft³ (600 kN-m/m³) compactive effort applied by the equipment and procedures of this test.
 - 3.2.3 *Modified Effort* – the term for the 56,000 ft-lbf/ft³ (2700 kN-m/m³) compactive effort applied by the equipment and procedures of this test.
 - 3.2.4 *Test Fraction (Finer Fraction) P_f in %* - the portion of the total sample used in performing the compaction test; it is the fraction passing the 1 in. (25.4 mm) sieve.

4. SUMMARY OF THE TEST METHOD

- 4.1 A soil at a selected water content is placed in eight (Procedure A) or six (Procedure B) layers into a mold of given dimensions with each layer compacted by the same number of blows of a 5.5 lbf (24.4 N) rammer dropped from a distance of 12 in. (305 mm) (standard effort), or of a 10 lbf (44.5 N) rammer dropped from a height of 18 in. (457 mm) (modified effort).

5. SIGNIFICANCE AND USE

- 5.1 Soil placed as engineering fill (embankments, foundation pads, road bases) is compacted to a dense state to obtain satisfactory engineering properties such as, shear strength, compressibility or permeability. Also, foundation soils are often compacted to improve their engineering properties. Laboratory compaction tests provide the means to create specimens with properties similar to those specific to the field compacted materials.

6. APPARATUS

- 6.1 *A split mold*, with an inside diameter of 152 mm (6 in) having a minimum height of 381 mm (15 in) (or a sufficient height to allow guidance of the compaction rammer for the final lift) shall be used for all materials having the maximum particle size (d_{max}) greater than 19 mm ($3/4$ in). For materials having the maximum particle size (d_{max}) less than 19 mm ($3/4$ in), a split mold with an inside diameter of 101.6 mm (4 in) and a minimum height of 254 mm (10 in) may be used.
- 6.2 *Rammer* – A rammer, either manually operated as described further in Sections 6.2.1, 6.2.2, or mechanically operated as described in 6.2.4.
 - 6.2.1 *Standard Effort* – The rammer shall fall freely through a distance of 12 +/- 0.05 in. (304.8 +/- 1.3 mm) from the surface of the specimen. The mass of the rammer shall be 5.5 +/- 0.02 lbm (2.5 +/- 0.01 kg), except as noted in Section 6.2.4.1, with a diameter when new of 2.000 +/- 0.005 in. (50.80 +/- 0.13 mm). The rammer shall be replaced if the striking face becomes worn or bellied to the extent that the diameter exceeds 2.000 +/- 0.01 in. (50.80 +/- 0.25 mm).
 - 6.2.2 *Modified Effort* – The rammer shall fall freely through a distance of 18 +/- 0.05 in. (457.2 +/- 1.6 mm) from the surface of the specimen. The mass of the rammer shall be 10 +/- 0.02 lbm (4.54 +/- 0.01 kg), except as noted in Section 6.2.4.1, with a diameter when new of 2.000 +/- 0.005 in. (50.80 +/- 0.13 mm). The rammer shall be replaced if the striking face becomes worn or bellied to the extent that the diameter exceeds 2.000 +/- 0.01 in. (50.80 +/- 0.25 mm).

Note 3 – It is a common and acceptable practice in the inch-pound system to assume that the mass of the rammer is equal to its mass determined using either a kilogram or pound balance and 1 lbf is equal to 1lbm or 0.4536 kg. or 1N is equal to 0.2248 lbm or 0.1020 kg.

- 6.2.3 *Manual Rammer* – The rammer shall be equipped with a guide sleeve that has sufficient clearance that the free fall of the rammer shaft and head is not restricted. The guide sleeve shall have at least four vent holes at each end (eight holes total) located with centers $3/4$ +/- $1/16$ in. (19.0 +/- 1.6 mm) from each end and spaced 90 degrees apart. The minimum diameter of the vent holes shall be $3/8$ in. (9.5 mm). Additional holes or slots may be incorporated in the guide sleeve.
- 6.2.4 *Mechanical Rammer-Circular Face* – The rammer shall operate mechanically in such a manner as to provide uniform and complete coverage of the specimen surface. There shall be 0.10 +/- 0.03 in. (2.5 +/- 0.8 mm) clearance between the rammer and the inside surface of the mold at its smallest diameter.

The mechanical rammer shall meet the calibration requirements of Test Methods D 2168. The mechanical rammer shall be equipped with a positive mechanical means to support the rammer when not in operation.

- 6.2.4.1 *Mechanical Rammer-Sector Face* – When used with the 6 in. (152.4 mm) mold, a sector face rammer may be used in place of the circular face rammer. The specimen contact face shall have the shape of a sector of a circle of radius equal to 2.90 +/- 0.02 in. (73.7 +/- 0.5 mm). The rammer shall operate in such a manner that the vertex of the sector is positioned at the center of the specimen.
- 6.3 *Sample Extruder (optional)* – A jack, frame or other device adapted for the purpose of extruding compacted specimens from the mold.
- 6.4 *Balance* – A class GP5 balance meeting the requirements of Specification D 4753 for a balance of 1-g readability.
- 6.5 *Drying Oven* – Thermostatically controlled, preferably of a forced-draft type and capable of maintaining a uniform temperature of 230 +/- 9 °F (110 +/- 5 °C) throughout the drying chamber.
- 6.6 *Straightedge* – A stiff metal straightedge of any convenient length but not less than 10 in. (254 mm). The total length of the straightedge shall be machined straight to a tolerance of +/- 0.0005 in. (+/- 0.1 mm). The scraping edge shall be beveled if it is thicker than 1/8 in. (3 mm).
- 6.7 *Sieves* – 3/4 in. (19.0 mm), conforming to the requirements of Specification E 11.
- 6.8 *Mixing Tools* – Miscellaneous tools such as mixing pan, spoon, trowel, spatula, etc., or a suitable mechanical device for thoroughly mixing the sample of soil with increments of water.

7. CALIBRATION

- 7.1 Perform calibrations before initial use, after repairs or other occurrences that might affect the test results, at intervals not exceeding 1000 test specimens, or annually, whichever occurs first, for the following apparatus:
- 7.1.1 *Balance* – Evaluate in accordance with Specification D 4753.
- 7.1.2 *Molds* – Determine the volume as described in Annex A-1.
- 7.1.3 *Manual Rammer* – Verify the free fall distance, rammer mass, and rammer face in accordance with Section 6.2. Verify the guide sleeve requirements in accordance with Section 6.2.3.
- 7.1.4 *Mechanical Rammer* – Calibrate and adjust the mechanical rammer in accordance with Test Methods D 2168. In addition, the clearance between the rammer and the inside surface of the mold shall be verified in accordance with Section 6.2.4.

8. TEST SAMPLE

- 8.1 The required sample mass for Procedure A is approximately 35 lbm (16 kg), and for Procedure B is approximately 65 lbm (29 kg) of dry soil. Therefore, the field sample should have a moist mass of at least 50 lbm (23 kg) and 100 lbm (45 kg), respectively.
- 8.2 Determine the percentage of material retained on the 3/4 in. (19 mm) as appropriate for choosing Procedure A or B. Make this determination by separating out a representative portion from the total sample and determining the percentages passing the sieves of interest by Test Methods D 422 or Method C 136. It is only necessary to calculate percentages for the sieve for which information is desired.

9. PREPARATION OF APPARATUS

- 9.1 Select the proper compaction mold in accordance with the procedure (A or B) being used. Determine and record its mass to the nearest gram. Assemble the mold.
- 9.2 Check that the rammer assembly is in good working condition and that parts are not loose or worn. Make any adjustments or repairs. If adjustments or repairs are made, the rammer must be recalibrated.

10. PROCEDURE

- 10.1 *Soils:*
- 10.1.1 Do not reuse soil that has been previously laboratory compacted.
- 10.1.2 Specimen material shall be prepared in accordance with Annex A-1
- 10.2 *Compaction* – After curing, if required, each specimen shall be compacted as follows:
- 10.2.1 Determine and record the mass of the mold or mold and base plate.
- 10.2.2 Assemble and secure the mold to the base plate. The mold shall rest on a uniform rigid foundation, such as provided by a cylinder or cube of concrete with a mass of not less than 200 lbm (91 kg). Secure the base plate to the rigid foundation. The method of attachment to the rigid foundation shall allow easy removal of the assembled mold and base plate after compaction is completed.

Note 4 – When compacting specimens wetter than optimum water content, uneven compacted surfaces can occur and operator judgment is required as to the average height of the specimen.

- 10.2.3 Compute the necessary number of blows/layer using Equation 1:

$$n = \frac{CE \cdot V}{N \cdot W \cdot h} \quad (1)$$

where

n = number of blows per layer

CE = compactive effort (standard or modified as defined in Sections 3.2.2, 3.2.3), ft-lbf/ft³ or kN-m/m³

V = volume of the sample, ft³ or m³

N = number of layers (8 for procedure A, 6 for procedure B)

W = weight of the rammer, lbf or N

h = drop height, ft or m.

- 10.2.4 Specimen material shall be prepared in accordance with Annex A-1
- 10.2.5 Specimens shall be compacted in (N) lifts of equal mass. Determine the mass of soil, W_L , required for each lift according to:

$$W_L = W_T/N$$

where

W_T = total mass of test specimen to produce the target density.

N = number of layers

Note 5 – In most cases the target density will be determined by field conditions. Where this is not the case, an appropriate target density can be determined by performing a laboratory moisture-density test according to the procedure of AASHTO T99 or T180.

- 10.2.6 Place the mass of wet soil, W_L , for one lift in the mold. In operating the manual rammer, take care to avoid lifting the guide sleeve during the rammer upstroke. Hold the guide sleeve steady and within 5° of vertical. Apply the blows at a uniform rate of approximately 25 blows/min and in such a manner as to provide complete, uniform coverage of the specimen surface.
- 10.2.7 Light scarify the top surface of the compacted lift to a depth of 3 mm prior to placing soil in the mold for the next lift.
- 10.2.8 Repeat Sections 10.2.6 and 10.2.7 until (N) lifts have been compacted.
- 10.2.9 Calculate and record the average bulk (wet) density of the entire specimen γ_s . If the average density differs from the target density by less than the tolerance allowed in Section 7.3.2 or 7.3.3 of the method, then proceed with Section 2 of Annex A-1.
- 10.2.10 If the average density differs from the target density by more than the tolerance allowed in Section 7.3.2 or 7.3.3 of the method, then increase or decrease the number of blows/layer and repeat compaction.

ANNEX A-4 KNEADING COMPACTION

1. SCOPE

- 1.1 This method covers kneading compaction of Type 3 soils for use in resilient modulus testing,
- 1.2 Specimens shall be compacted in five lifts (layers) in a split mold. Either a pneumatic manual compactor or a hydraulic mechanical compactor provides the compactive effort. The number of tamps per lift and the compaction pressure are constant for all lifts. The compaction pressure is adjusted to achieve the required laboratory density.

2. SIGNIFICANCE AND USE

- 2.1 Kneading compaction will yield a structure in Type 3 soils that is characteristically obtained by field compaction methods. Thus, when compacted dry of optimum moisture content the soil structure is mostly flocculated, and when compacted wet of optimum is mostly dispersed.
- 2.2 This procedure may result in a gradient of soil density within the specimen, which may affect the resilient modulus, M_R . Where it is important achieve a uniform density in all specimen layers, the procedure described in Annex A-3 should be used.

3. APPARATUS

- 3.1 Test Specimen Mold – A split mold with a removable collar, as shown in Figure A-4-1, shall be used. The minimum mold inside diameter should be 71 mm. The mold shall have a minimum inside diameter not less than 5 times the maximum particle size. The trimmed length of all specimens should be at least two times the diameter.

Note 1 – As an alternative for soils lacking in cohesion, a mold with the membrane installed and held by vacuum, as described in Annex A-2, may be used.

- 3.2 Manual Compactor – A pneumatic manual compactor, as shown in Figure A-4-2, may be used. The volume of the air reservoir shall be a minimum of 200 times the volume of the compactor at full piston extension. The compactor rod shall be threaded to receive tamping feet of various diameters from 13 to 19 mm. The reservoir pressure regulator and gage shall be capable of adjusting and reading air pressure from zero to 400 kPa. Calibration shall be checked annually using a calibrated proving ring or load cell.

Note 2 – This device is modeled after the Harvard miniature compactor. A pneumatically operated compactor is

referred to a spring-loaded compactor due to the more consistent compactive effort and reduced operator variability.

- 3.3 Mechanical Compactor – A hydraulic mechanical compactor capable of applying a foot pressure from 250 to 2000 kPa and meeting the requirements of AASHTO T 190 may be used. When a mechanical compactor is used, the split mold inside diameter shall be chosen as required to work with the compactor, provided that the requirements of Section 3.1 are met.

4. MANUAL COMPACTION PROCEDURE

- 4.1 Specimen material shall be prepared in accordance with Annex A-1. The specimen will be fabricated 6 to 8 mm overheight to allow trimming to a square end. Increase the quantity of material prepared to allow for the trimming.
- 4.2 Specimens shall be compacted in five lifts of equal mass. Determine the mass of soil, W_L , required for each lift according to:

$$W_L = W_T/5$$

where

W_T = total mass of test specimen to produce the target density including the allowance for trimming.

Note 3 – In most cases, the target density will be determined by field conditions. Where this is not the case, an appropriate target density can be determined by performing a laboratory moisture-density test according to the procedure of AASHTO T99 or T180.

- 4.3 Adjust the air reservoir pressure to the level to be used in the first trial. Thread the desired diameter tamper foot onto the compactor piston. Determine the required number of tamps for one coverage of each lift according to Table A-4-1.

Note 4 – Maintaining a database of compaction variables, soil types and moisture density conditions will assist

TABLE A-4-1 Number of Tamps for One Coverage of a Lift – Manual Procedure

Specimen Diameter	Tamp Foot Diameter			
	13 mm	15 mm	17 mm	19 mm
71 mm	30	22	17	14
86 mm	44	33	26	20
102 mm	62	46	36	29
152 mm	137	103	80	64

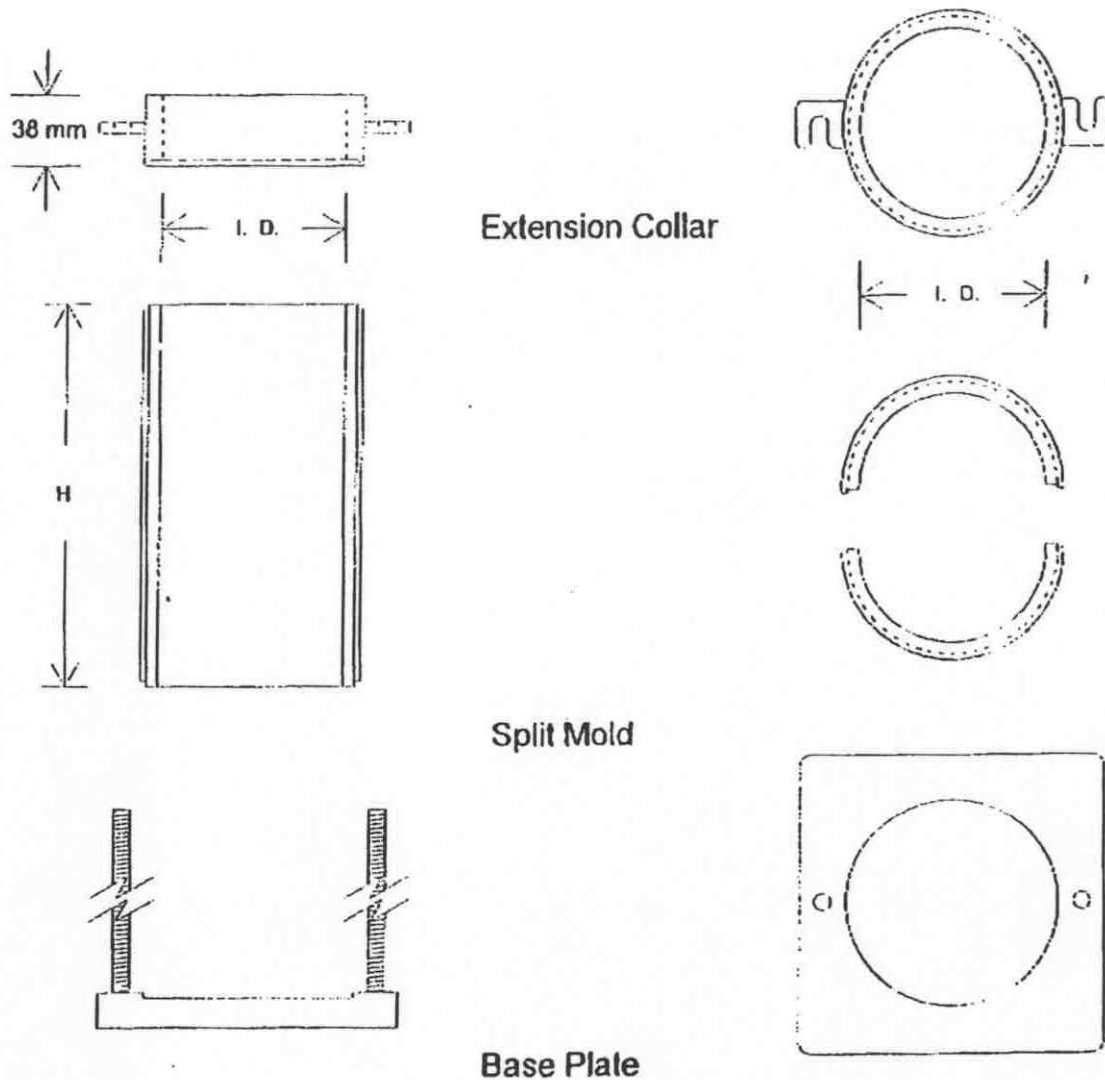

Notes:

1. Mold halves are connected with 2 hose clamps
2. $H = I.D. \times 2$

Fig. A-4-1. Specimen Mold (AASHTO TP46)

with selection of starting air pressure to achieve the desired specimen density.

- 4.4 Place the mass of wet soil, W_L , for one lift in the mold. Using a spatula, draw the soil away from the edge of the mold to form a slight mound in the center.
- 4.5 Holding the compactor vertically, apply the required number of tamps to the soil. Tamps should be distributed evenly over the specimen cross-section. Each tamp

should be applied slowly with just enough force to move the piston approximately 5 to 10 mm in the compactor.

Note 5 – *Caution.* The piston should not be moved all the way to the end of the compactor, as this will cause an unregulated force to be applied.

- 4.6 Light scarify the top surface of the compacted lift to a depth of 3 mm prior to placing soil in the mold for the next lift.

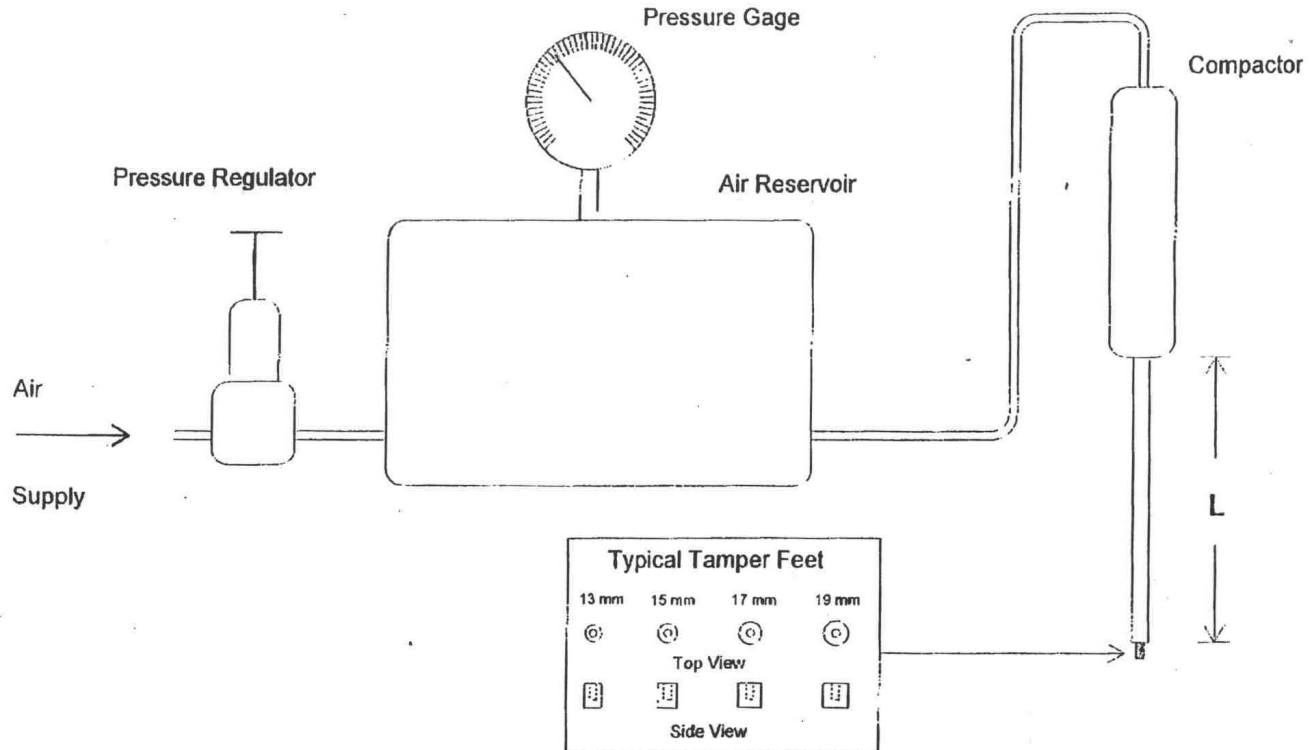

Notes:

1. $L = \text{Specimen Ht.} + \text{Collar Ht.} - \text{Layer Ht.} + 12 \text{ mm}$
2. Minimum reservoir volume = 200 x compactor volume
3. Minimum gage accuracy is 0.5 Pa
4. Compactor air cylinder is rolling diaphragm type

Fig. A-4-2. Pneumatic Kneading Compaction System (AASHTO TP-46)

4.7 Repeat Sections 4.5 and 4.6 until five lifts have been compacted. Continue with Section 6.1.

5.6 Repeat Sections 5.3 through 5.5 until five lifts have been compacted.

5. MECHANICAL COMPACTION PROCEDURE

- 5.1 Specimen material shall be prepared and weighed in accordance with Sections 4.1 and 4.2
- 5.2 Adjust the foot pressure to the level to be used in the first trial.
- 5.3 Place the mass of wet soil, W_L , for one lift in the mold. Using a spatula, draw the soil away from the edge of the mold to form a slight mound in the center.
- 5.4 Apply one revolution of tamps to the first lift (normally 5 to 7 tamps per revolution, according to AASHTO T 190) to achieve one coverage over the specimen cross section.
- 5.5 Lightly scarify the top surface of the compacted lift to a depth of 3 mm prior to placing soil in the mold for the next lift.

6. SPECIMEN TRIMMING AND CALCULATIONS

- 6.1 Remove the collar and carefully screed off the specimen to the top of the mold. Small depressions in the screeded surface caused by removal of larger particles shall be filled with fines. Remove the split mold from the base halves from the specimen.
- 6.2 Determine and record the mass of the entire specimen to the nearest gram. Use a tabular form as in Figure A-4-3 to record the data.
- 6.3 Determine and record the moisture content of the remaining soil according to AASHTO T 265.
- 6.4 Calculate and record the average bulk (wet) density of the entire specimen. If the average density differs from the target density by less than the tolerance allowed in Section 7.3.2 or 7.3.3, then proceed with Section 2 of Annex A-1.

PROJECT				
Target Moisture (%)		Target Dry Density (Kg/m ³)		
Mold Dimensions - diam. x ht. (mm)		Mold Volume (cm)		Mold Wt. (gms)

Specimen No.			
Wt. of scalped soil (gms)			
No. Tamps per Layer			
Air or Tamper Foot Pressure (Pa)			
Wt. specimen & mold (gms)			
Wt. mold assembly (gms)			
Wt. moist soil (gms)			
Wt. dry soil (gms)			
Moisture Content (%)			
Dry Density (Kg/m ³)			
Wet Density (Kg/m ³)			

PERCENT DIFFERENCES

Target & Specimen Dry Density (%)			
Target & Specimen Moisture (%)			

Specimen No.	Soil Description

REMARKS

Fig. A-4-3. Kneading Compaction

6.5 If the average density differs from the target density by more than the tolerance allowed in Section 7.3.2 or 7.3.3, then the compaction pressure shall be adjusted to increase or decrease the average density toward the target density. Repeat Sections 4.4 or 4.5.

Note 6 – If a sufficient quantity of material is available, it is preferable to use new material for each subsequent specimen. If the old material is reused, this will have an effect on the structure of subsequently compacted specimens.

ANNEX A-5 SPECIMEN END PREPARATION

To give better contact between the top and bottom plates and the specimen, the ends of specimens can be grouted with hydrostone. The clamps used to grout the specimen ends are shown in Figure A-5-1. The grouting procedure is shown in Figure A-5-2 and described as follows:

1. Mix 28 ml of water with 70 gm of hydrostone cement until it becomes a liquid. The water-hydrostone cement (W/C) ratio is 0.4 by weight.
2. Let the mixture hydrate for about 15 min. so as to become a paste.
3. Pour the paste into the aluminum split clamps around the pedestal shown in Figure A-5-2 (a). Place the sample on top of the hydrostone grout.
4. Center the sample vertically by using an acrylic plate with 5.0-in-diameter hole in the middle and supported

horizontally on three steel rods fixed to the base of the triaxial cell as shown in Figure A-5-2 (b).

5. Remove the clamps from around the bottom of the sample 10 min. after pouring the grout into the mold.
6. Repeat Steps 1 and 2.
7. Place the clamps around the top end of the sample using the acrylic plate as a support as shown in Figure A-5-2 (b).
8. Repeat Step 3.
9. Place the top cap on the top of the hydrostone paste and center it in the direction to fit the LVDT clamps.
10. Place a rubber membrane around the specimen and form a seal using two rubber O-rings. Leave it for about two hours to allow the hydrostone paste to reach its required strength.
11. Fix the LVDT rod carriers to the bottom of the triaxial cell and attach the LVDTs to them.

The specimen is now ready for testing.

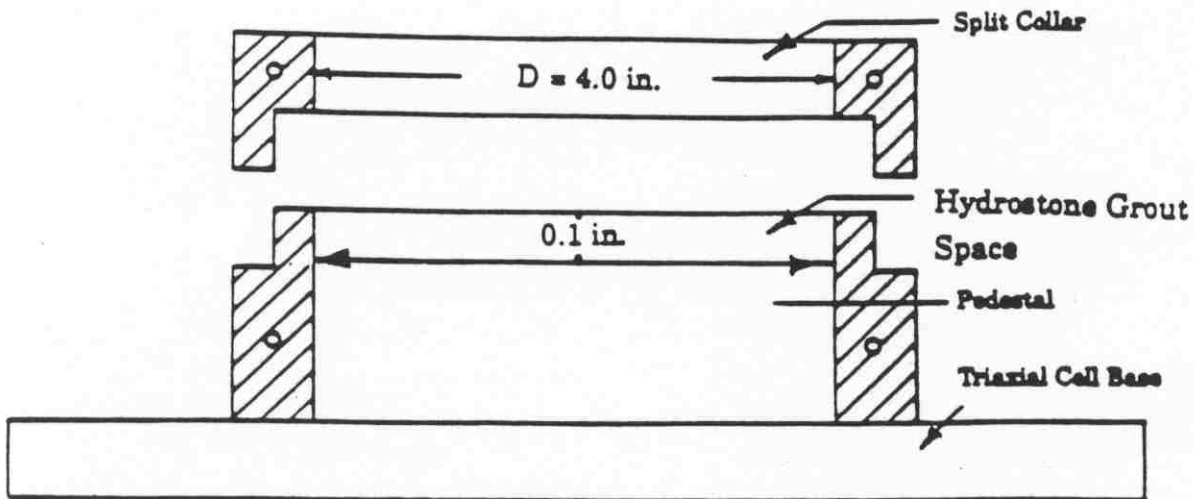
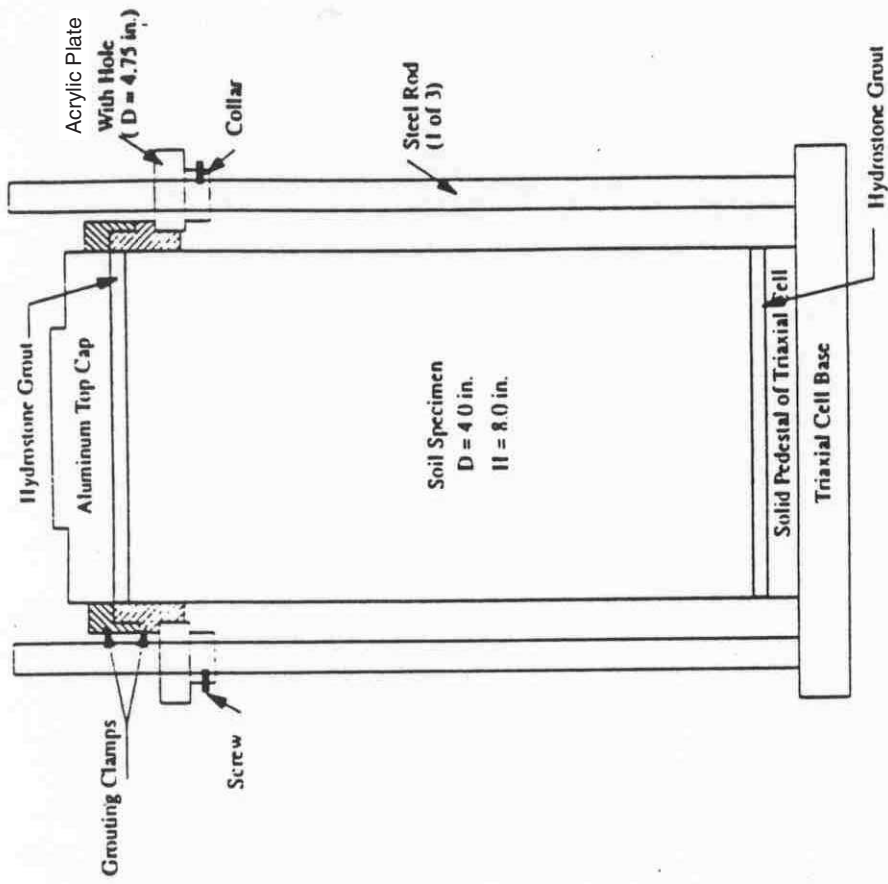
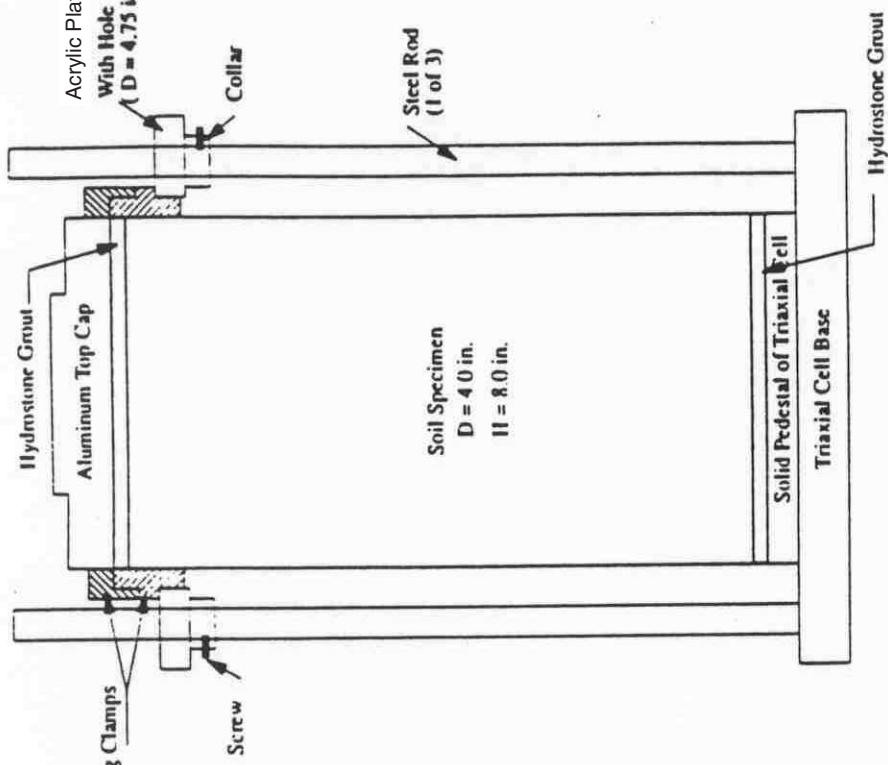

Fig. A-5-1. Clamps Used in Grouting the Ends of the Test Specimen



(a) Grouting the bottom end



(b) Grouting the top end

Fig. A-5-2. Setup for Grouting the Top and Bottom Ends of a Specimen

ANNEX A-6 OBTAINING A UNIFORM DENSITY IN TYPE 3 SOILS

1. SCOPE

- 1.1 This method provides procedures for measuring and minimizing or eliminating density gradients in a specimen of Type 3 soil for use in resilient modulus testing.
- 1.2 Specimens should be compacted in five lifts (layers) in a density gradient mold. Kneading compaction (Annex A-4) shall be used. The number of tamps per lift shall be adjusted for each lift to avoid imparting a density gradient to the specimen.

2. SIGNIFICANCE AND USE

- 2.1 A specimen fabricated in layers, with each lift receiving equal compactive effort, will typically exhibit a density gradient with the first lift compacted being more dense than the last. To measure this effect, the density gradient mold is used to determine the density of each lift. A trial and error process is used to adjust the compactive effort for each lift until the desired specimen density is obtained with minimum gradient.
- 2.2 Density gradients can occur with vibratory (Annex A-2), impact (Annex A-3) or kneading (Annex A-4) compaction methods. The density gradient mold can be used in conjunction with any of the three compaction methods to measure density gradients from top to bottom within the specimen.
- 2.3 For the most accurate characterization of resilient modulus, the density gradient within the test specimen should be minimized. The test specimen should have a structure that closely approximates the one that will be obtained in field compaction. The use of kneading compaction can help to achieve the proper structure.

3. APPARATUS

- 3.1 Density Gradient Mold – The density gradient mold is shown in Figure A-6-1. This is a split mold with the inside milled to receive five interchangeable solid rings that have been permanently numbered from 1 to 5. The ring I.D. shall be equal to the mold I.D. The mold height and diameter shall be the same as is used in preparing specimens for the resilient modulus testing (Annex A-4).
- 3.2 Compactor – To measure the density gradient, the same type of compactor shall be used as is used in preparing specimens for resilient modulus testing, as described in Annex A-2, A-3, or A-4. To minimize the density gradient, either a manual or mechanical kneading compactor, as described in Annex A-4, shall be used.

4. PROCEDURE FOR COMPACTING SPECIMENS TO MEASURE DENSITY GRADIENTS

- 4.1 Specimen material shall be prepared in accordance with Annex A-1. If the maximum particle size exceeds 25 percent of the mold inside diameter, the oversize particles shall be scalped. The specimen will be fabricated 6 to 8 mm over height to allow trimming to a square end. Increase the quantity of material prepared to allow for the trimming.
- 4.2 Specimens shall be compacted to the same diameter, and using the same apparatus and procedure as is used in preparing specimens for resilient modulus testing, as described in Annex A-2, A-3, or A-4.
- 4.3 Remove the collar and carefully screed off the specimen to the top of the mold. Small depressions in the screeded surface, caused by removal of larger particles, shall be filled with fines. Remove the split mold from the base and the mold halves from the specimen. Leave the five rings on the specimen.
- 4.4 Determine and record the net mass of the entire specimen to the nearest gram. To do this, subtract the mass of the specimen with rings attached.
- 4.5 Determine and record the moisture content of the remaining soil according to AASHTO T 265.
- 4.6 Using a hacksaw or other abrasive device, carefully cut the specimen into five pieces. Each cut should be made midway between the rings. Screed off each piece to form square ends at the top and bottom of each ring. Small depressions in the screeded surface, caused by removal of larger particles, shall be filled with fines.
- 4.7 Determine and record the net mass of each numbered piece to the nearest gram. Use a tabular form, as in Figure A-6-2, to record the data.
- 4.8 Determine and record the moisture content of each numbered piece.
- 4.9 Calculate and record the average bulk (wet) density of the entire specimen, γ_s , and densities of each five pieces, γ_s to γ_5 .
- 4.10 If the maximum difference between the density of each individual piece and the average density is 1.0 percent or less, report the density gradient as being uniform. If the maximum difference between the density of each individual piece and the average density is more than 1.0 percent, report the density gradient as being non-uniform.

5. PROCEDURE FOR COMPACTING TEST SPECIMENS TO ACHIEVE A UNIFORM DENSITY

- 5.1 Follow the procedure in Sections 4.1 through 4.9, using either the manual or mechanical kneading compaction procedure (Annex A-4).

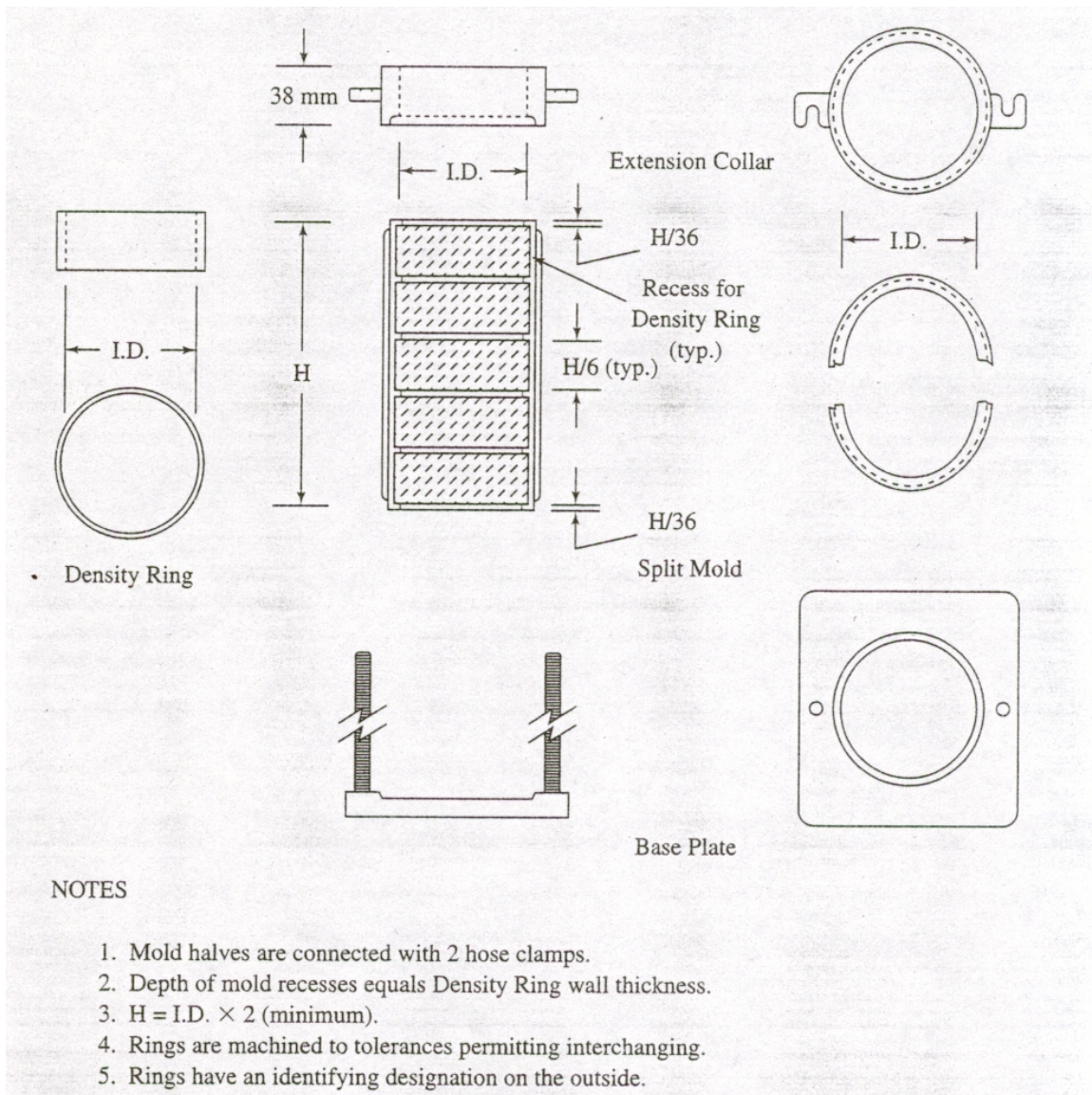

Figure A-6-1. Density Gradient Mold

Note 1 – The requirements in Annex A-4 that the number of tamps per lift be constant is waived. However, it is recommended that the number of tamps per lift be constant for each lift in the first trial specimen in order to establish that a density gradient does exist.

5.2 If the average bulk density differs from the target density by more than the tolerance allowed in Section 7.3.2 or 7.3.3, then the compaction pressure shall be adjusted, holding the number of tamps per lift constant, to increase or decrease the average density toward the target density. Repeat 5.1

5.3 After the target average density is achieved, check the density uniformity according to Section 4. If the density

is non-uniform, hold the compaction pressure constant and adjust the number of tamps per lift until a uniform density gradient is achieved.

Note 2 – If a sufficient quantity of material is available, it is preferable to use new material for each subsequent specimen. If the old material is reused it will have an effect on the structure of subsequently compacted specimens.

Use the compaction pressure and number of tamps per lift thus determined to prepare specimens for resilient modulus testing using the procedure in Annex A-4.

CHECK FOR DENSITY GRADIENT

PROJECT											
Sample No.			Soil Description								
Target Moisture (%)			Target Density (kg/m ³)			*Air or Tamper Foot Pressure (Pa)					
Was Sample Scalped?			Wt. scalped soil (gms)			Mold Dimensions – diam. × ht. (mm)					
Ring Volume (cm ³)											

Layer Position in Mold	**Order of Compaction	Ring No.	*No. of Temps per Layer	Weights (gms)					Moisture (%)	Layer Dry Density (kg/m ³)	Percent Difference Between Average Density & Layer density
				Ring	Ring + Soil (wet)	Soil (wet)	Soil (dry)	Water			
1 (top)											
2											
3											
4											
5 (bottom)											

* Required for kneading compaction (Annex A4).
 ** For static compaction, middle layer is usually first.
 For kneading compaction, bottom layer is first.

Average Layer Density (kg/m ³)	Average Moisture (%)	Percent Difference Between Target Density & Average Density (%)	Percent Difference Between Target Moisture & Average Moisture (%)

REMARKS

Figure A-6-2

These digests are issued in order to increase awareness of research results emanating from projects in the Cooperative Research Programs (CRP). Persons wanting to pursue the project subject matter in greater depth should contact the CRP Staff, Transportation Research Board of the National Academies, 500 Fifth Street, NW, Washington, DC 20001.

THE NATIONAL ACADEMIES™

Advisers to the Nation on Science, Engineering, and Medicine

The nation turns to the National Academies—National Academy of Sciences, National Academy of Engineering, Institute of Medicine, and National Research Council—for independent, objective advice on issues that affect people's lives worldwide.

www.national-academies.org

TRANSPORTATION RESEARCH BOARD
500 Fifth Street, NW
Washington, DC 20001