

IDEA

**Innovations Deserving  
Exploratory Analysis Programs**

**HIGH-SPEED RAIL**

**New IDEAS  
for High-Speed Rail**

**Annual Progress Report**

JANUARY 2005

TRANSPORTATION RESEARCH BOARD  
OF THE NATIONAL ACADEMIES

# TRANSPORTATION RESEARCH BOARD

---

## EXECUTIVE COMMITTEE 2004

### OFFICERS

CHAIR: **MICHAEL S. TOWNES**, President and CEO, Hampton Roads Transit, Hampton, VA

VICE CHAIR: **JOSEPH H. BOARDMAN**, Commissioner, New York State DOT

EXECUTIVE DIRECTOR: **ROBERT E. SKINNER, JR.**, Transportation Research Board

### MEMBERS

**MICHAEL W. BEHRENS**, Executive Director, Texas DOT

**SARAH C. CAMPBELL**, President, TransManagement, Inc., Washington, DC

**E. DEAN CARLSON**, Director, Carlson Associates, Topeka, KS

**JOHN L. CRAIG**, Director, Nebraska Department of Roads

**DOUGLAS G. DUNCAN**, President and CEO, FedEx Freight, Memphis, TN

**GENEVIEVE GIULIANO**, Director, Metrans Transportation Center and Professor, School of Policy, Planning, and Development, USC, Los Angeles

**BERNARD S. GROSECLOSE, JR.**, President and CEO, South Carolina State Ports Authority

**SUSAN HANSON**, Landry University Professor of Geography, Graduate School of Geography, Clark University

**JAMES R. HERTWIG**, President, CSX Intermodal, Jacksonville, FL

**GLORIA J. JEFF**, Director, Michigan DOT

**ADIB K. KANAFANI**, Cahill Professor of Civil Engineering, University of California, Berkeley

**RONALD F. KIRBY**, Director of Transportation Planning, Metropolitan Washington Council of Governments

**HERBERT S. LEVINSON**, Principal, Herbert S. Levinson Transportation Consultant, New Haven, CT

**SUE MCNEIL**, Director, Urban Transportation Center and Professor, College of Urban Planning and Public Affairs and Department of Civil and Material Engineering, University of Illinois, Chicago

**MICHAEL D. MEYER**, Professor, School of Civil and Environmental Engineering, Georgia Institute of Technology

**CAROL A. MURRAY**, Commissioner, New Hampshire DOT

**JOHN E. NJORD**, Executive Director, Utah DOT

**DAVID PLAVIN**, President, Airports Council International, Washington, DC

**JOHN H. REBENSDORF**, Vice President, Network Planning and Operations, Union Pacific Railroad Co., Omaha, NE

**PHILIP A. SHUCET**, Commissioner, Virginia DOT

**C. MICHAEL WALTON**, Ernest H. Cockrell Centennial Chair in Engineering, University of Texas, Austin

**LINDA S. WATSON**, Executive Director, LYNX—Central Florida Regional Transportation Authority, Orlando, FL

**MARION C. BLAKEY**, Federal Aviation Administrator, U.S.DOT (ex officio)

**SAMUEL G. BONASSO**, Acting Administrator, Research and Special Programs Administration, U.S.DOT (ex officio)

**REBECCA M. BREWSTER**, President and COO, American Transportation Research Institute, Smyrna, GA (ex officio)

**GEORGE BUGLIARELLO**, Chancellor, Polytechnic University and Foreign Secretary, National Academy of Engineering (ex officio)

**THOMAS H. COLLINS** (Adm., U.S. Coast Guard), Commandant, U.S. Coast Guard (ex officio)

**JENNIFER L. DORN**, Federal Transit Administrator, U.S.DOT (ex officio)

**EDWARD R. HAMBERGER**, President and CEO, Association of American Railroads (ex officio)

**JOHN C. HORSLEY**, Executive Director, American Association of State Highway and Transportation Officials (ex officio)

**RICK KOWALEWSKI**, Deputy Director, Bureau of Transportation Statistics, U.S.DOT (ex officio)

**WILLIAM W. MILLAR**, President, American Public Transportation Association (ex officio)

**BETTY MONRO**, Acting Administrator, Federal Railroad Administration, U.S.DOT (ex officio)

**MARY E. PETERS**, Federal Highway Administrator, U.S.DOT (ex officio)

**SUZANNE RUDZINSKI**, Director, Transportation and Regional Programs, U.S. Environmental Protection Agency (ex officio)

**JEFFREY W. RUNGE**, National Highway Traffic Safety Administrator, U.S.DOT (ex officio)

**ANNETTE M. SANDBERG**, Federal Motor Carrier Safety Administrator, U.S.DOT (ex officio)

**WILLIAM G. SCHUBERT**, Maritime Administrator, U.S.DOT (ex officio)

**JEFFREY N. SHANE**, Under Secretary for Policy, U.S.DOT (ex officio)

**CARL A. STROCK** (Maj. Gen., U.S. Army), Chief of Engineers and Commanding General, U.S. Army Corps of Engineers (ex officio)

**ROBERT A. VENEZIA**, Program Manager of Public Health Applications, National Aeronautics and Space Administration (ex officio)

---

Publications of the IDEA Programs are available on the internet at [national-academies.org/trb/IDEA](http://national-academies.org/trb/IDEA).

Further information is available by contacting the IDEA Program Office by phone (202-334-3310) or fax (202-334-3471).

Transportation Research Board publications may be ordered directly from the TRB Business Office (202-334-3213), through the internet at [national-academies.org/trb](http://national-academies.org/trb), or by annual subscription through organization or individual affiliation with TRB. Affiliates and library subscribers are eligible for substantial discounts.

For further information, contact the Transportation Research Board Business Office, National Research Council

2101 Constitution Avenue, NW, Washington, DC 20418, (telephone 202-334-3214; fax 202-334-2519; or email [TRBsales@nas.edu](mailto:TRBsales@nas.edu)).

# **NEW IDEAS FOR HIGH-SPEED RAIL SYSTEMS**



**An Annual Progress Report of the  
High-Speed Rail IDEA Program**

**JANUARY 2005**

**TRANSPORTATION RESEARCH BOARD**  
*OF THE NATIONAL ACADEMIES*

# HIGH-SPEED RAIL IDEA PROGRAM COMMITTEE

## Chairman

Mike Franke, PE  
*Senior Director, Planning & Business Development-  
 Midwest, AMTRAK*

## Members

Alan J. Bing, PhD  
*Technical Specialist, ICF Consulting*

Tim DePaepe  
*Director of Research, The Brotherhood of Railroad  
 Signalmen*

Peter French  
*Assistant Vice President, Safety & Performance  
 Analysis, Association of American Railroads*

John Hovane, PE  
*General Director-Design, Union Pacific Railroad*

Ron Hynes  
*Associate Director, Railroad Division, National  
 Transportation Safety Board*

Denise E. Lyle  
*Managing Director-Operating Technologies, CSX  
 Transportation*

Stephen Roop, PhD  
*Director, Multimodal Freight Transportation Pro-  
 grams, Texas Transportation Institute*

Bill Schafer, Director  
*Corporate Affairs, Norfolk Southern Corp.*

Thomas P. Smithberger, PE  
*Senior Vice President and National Director of  
 Railroads, HDR, Inc.*

Mark Stehly  
*The Burlington Northern and Santa Fe Railway  
 Company*

Warren D. Weber,  
*Chief, Division of Rail, CALTRANS*

Robert Wright  
*Manager of R&D, Alston Transportation*

## Liaison Members

Roy Allen  
*President Transportation Technology Center, Inc.*

David Gibson  
*Research Engineer, FHWA*

Robert McCown  
*Director, Technical Development Program, Federal  
 Railroad Administration*

R. Leo Penne  
*Program Director, Intermodal & Industry Activities,  
 AASHTO*

Venkat Pindiprolu  
*Program Manager, Federal Transit Administration*

K.T. Thirumalai, PhD  
*Chief Engineer, Research and Special Programs  
 Administration*

## FRA Staff

Steve Sill  
*General Engineer/Program Manager, Next Genera-  
 tion HSR Program*

## IDEA Program Staff

Charles Taylor  
*Senior Program Officer*

## Special Programs Staff

Neil F. Hawks  
*Director, Special Programs*

Debbie Irvin  
*Administrative Assistant*

## THE NATIONAL ACADEMIES

*Advisers to the Nation on Science, Engineering, and Medicine*

The **National Academy of Sciences** is a private, nonprofit, self-perpetuating society of distinguished scholars engaged in scientific and engineering research, dedicated to the furtherance of science and technology and to their use for the general welfare. Upon the authority of the charter granted to it by the Congress in 1863, the Academy has a mandate that requires it to advise the federal government on scientific and technical matters. Dr. Bruce M. Alberts is president of the National Academy of Sciences.

The **National Academy of Engineering** was established in 1964, under the charter of the National Academy of Sciences, as a parallel organization of outstanding engineers. It is autonomous in its administration and in the selection of its members, sharing with the National Academy of Sciences the responsibility for advising the federal government. The National Academy of Engineering also sponsors engineering programs aimed at meeting national needs, encourages education and research, and recognizes the superior achievements of engineers. Dr. Wm. A. Wulf is president of the National Academy of Engineering.

The **Institute of Medicine** was established in 1970 by the National Academy of Sciences to secure the services of eminent members of appropriate professions in the examination of policy matters pertaining to the health of the public. The Institute acts under the responsibility given to the National Academy of Sciences by its congressional charter to be an adviser to the federal government and, upon its own initiative, to identify issues of medical care, research, and education. Dr. Harvey V. Fineberg is president of the Institute of Medicine.

The **National Research Council** was organized by the National Academy of Sciences in 1916 to associate the broad community of science and technology with the Academy's purposes of furthering knowledge and advising the federal government. Functioning in accordance with general policies determined by the Academy, the Council has become the principal operating agency of both the National Academy of Sciences and the National Academy of Engineering in providing services to the government, the public, and the scientific and engineering communities. The Council is administered jointly by both Academies and the Institute of Medicine. Dr. Bruce M. Alberts and Dr. Wm. A. Wulf are chair and vice chair, respectively, of the National Research Council.

[www.national-academies.org](http://www.national-academies.org)

## INTRODUCTION

IDEA (Innovations Deserving Exploratory Analysis) Programs explore promising but unproven concepts with potential to advance surface transportation systems. The High-Speed Rail (HSR) IDEA Program is funded by the Federal Railroad Administration (FRA). HSR-IDEA projects are selected for their potential role in upgrading the existing U.S. rail system to accommodate operations up to 100 mph and beyond in support of FRA's next-generation HSR technology development program. The HSR-IDEA Program is one of the four integrated IDEA programs managed by the Transportation Research Board. The other three IDEA programs are:

- NCHRP Highway IDEA, which focuses on concepts for advancing the design, construction, safety, and maintenance of highways;
- Safety IDEA, which promotes innovative approaches to improving ground transportation safety; and
- Transit IDEA, which supports innovative approaches for improving transit operations and safety.

Since its creation in 1997, HSR-IDEA has received commitments for more than \$5 million in support from FRA. Since 1996, FRA also committed \$1.5 million to intelligent transportation system projects that support high-speed rail implementation through general improvements in surface transportation infrastructure and operations in the other modes.

Approximately 20 percent of HSR-IDEA awards have been to small companies (fewer than 10 employees), 40 percent to larger research, manufacturing, and consulting companies, and 40 percent to universities. HSR-IDEA has made awards to about 25 percent of the proposals it has received. The investigations that resulted from these awards are reported in this document, which is organized by these four categories: operations, communications, and train control; highway-railroad crossing safety; track and structures; and rolling stock.

For additional information on these IDEA projects and how to prepare and submit research proposals, visit our website at [www.trb.org/idea](http://www.trb.org/idea).

# TABLE OF CONTENTS

Page

## **OPERATIONS, COMMUNICATIONS, and TRAIN CONTROL**

HSR-3/ITS-31: Laser Optics Communications System, <i>SUNY at Stony Brook, Stony Brook, New York</i> <i>Sheldon Chang, Principal Investigator</i>	3
HSR-4/ITS-37: Rail Vibration Analysis to Detect Approaching Trains <i>Raven, Inc., Alexandria, Virginia</i> <i>James J. Genova, Principal Investigator</i>	4
HSR-5/ITS-39: Proximity Warning System for Locomotives <i>Pulse Electronics, Inc. Rockville, Maryland</i> <i>Robert Kull, Principal Investigator</i>	5
HSR-14/27: Multiple Sensor Inertial Measurement System for Locomotive Navigation <i>ENSCO, Inc., Cocoa Beach, Florida</i> <i>Fred Riewe, Principal Investigator</i>	6
HSR-17: Automatic Warning System for Track Maintenance Workers <i>Raven, Inc., Alexandria, Virginia</i> <i>James Genova, Principal Investigator</i>	8
HSR-18: An Investigation into the Use of Buried Fiber-Optic Filament to Detect Trains and Broken Rail <i>Texas Transportation Institute, College Station, Texas</i> <i>Stephen Roop, Principal Investigator</i>	10
HSR-19: Fiber-Optic Sensors for High-Speed Rail Applications <i>University of Illinois</i> <i>S. L. Chuang, Principal Investigator</i>	12
HSR-22/35: DGPS Locomotive Navigation System <i>Seagull Technology, Inc., Los Gatos, California</i> <i>Tysen Mueller, Principal Investigator</i>	14

## **HIGHWAY-RAILROAD CROSSING SAFETY**

HSR-1/ITS 29: Scanning Radar Antenna for Collision Avoidance, <i>WaveBand Corporation, Torrence, California</i> <i>Lev Sadoz'nik, Principal Investigator</i>	19
--	----



HSR-2/6:	Wide-Angle Video System for Grade Crossings <i>Intelligent Highway Systems, White Plains, New York, Eugene Waldenmaier, Principal Investigator</i>	20
HSR-8:	Microwave Train Detection System for Grade Crossings <i>O'Conner Engineering, Inc. Benicia, California Joe O'Conner, Principal Investigator</i>	21
HSR-10:	A Neural Network Video Sensor Application for Railroad Crossing Safety <i>Nestor, Inc., Providence, Rhode Island Douglas Reilly, Principal Investigator</i>	23
HSR-11:	Quad-Gate Crossing Control System <i>Rail Safety Engineering, Inc, Rochester, New York Jeff Twombly, Principal Investigator</i>	25
HSR-13/ITS-69:	Grade Crossing Obstacle Detection Radar <i>WaveBand Corp., Torrence, California Lev Sadochnik, Principal Investigator</i>	27
HSR-16:	Advanced Intersection Controller Response to Railroad Preemption <i>Texas Transportation Institute Steven Venglar, Principal Investigator</i>	29

## **TRACK and STRUCTURES**

HSR-15/28:	Hybrid Uni-Axial Strain Transducer <i>University of Utah, Salt Lake City Hosin Lee, Principal Investigator</i>	35
HSR-23/43:	Hybrid Composite Beam System <i>Teng &amp; Associates, Inc., Chicago, Illinois John Hillman, Principal Investigator</i>	38
HSR-24/41:	Improved Reliability of Thermite Field Welds <i>University of Illinois, Champaign, Illinois Fred Lawrence, Principal Investigator</i>	41
HSR-25:	Neural-Network Based Rail Flaw Detection <i>University of Illinois, Champaign, Illinois Jamshid Ghaboussi, Principal Investigator</i>	43
HSR-26:	High Precision GPS for Monitoring Rail <i>University of Illinois, Champaign, Illinois David Munson, Principal Investigator</i>	45

HSR-30/48:	Vibration Measurements of Rail Stress <i>University of Illinois, Champaign, Illinois</i> <i>Richard Weaver, Principal Investigator</i>	46
HSR-37:	Electroslag Field Welding of Railroad Rail <i>Electroslag Systems</i> <i>Dan Danks, Principal Investigator</i>	48
HSR-38:	Feasibility of Locomotive-Mounted Broken Rail Detection <i>Analogic Engineering, Inc.</i> <i>Steven Turner, Principal Investigator</i>	50
HSR-40:	Rubber-Modified Asphalt Concrete for Railway Roadbeds <i>Case Western Reserve University</i> <i>David Zeng, Principal Investigator</i>	51
HSR-42:	Acoustic Broken Rail Detection System <i>San Francisco Bay Area Rapid Transit District</i> <i>John Evans, Principal Investigator</i>	52
HSR-46:	Magnetorheological Damping for Spring Rail Frog Switches <i>Texas A&amp;M Research Foundation</i> <i>Les Olson, Principal Investigator</i>	54

## **ROLLING STOCK**

HSR-20/34:	Metal Foams for Improved Crash Energy Absorption <i>Fraunhofer Resource Center</i> <i>Ken Kremer, Principal Investigator</i>	57
HSR-29:	Continuous Locomotive Emissions Analyzer <i>Scintexar Corporation</i> <i>Joseph Roehl, Principal Investigator</i>	59
HSR-32:	High-Strength Lightweight Car Bodies <i>Surface Treatment Technologies, Inc., Baltimore, Maryland</i> <i>Tim Langan, Principal Investigator</i>	61
HSR-39:	Hand-Held Wheel Crack Detection Device <i>International Electronic Machines</i> <i>Zack Mian, Principal Investigator</i>	64
HSR-44:	Permanent Magnet DC Traction Motor <i>Spad Engineering</i> <i>Nick Rivera, Principal Investigator</i>	65



HSR-45:	Crash Energy Absorption System for Rail Passenger Seats <i>Paragrate</i> <i>Stephen Knotts, Principal Investigator</i>	67
HSR-47:	Application of LAHUT Technology for Wayside Cracked Wheel Technology <i>Transportation Technology Center, Inc.</i> <i>Richard Morgan, Principal Investigator</i>	69

**Operations, Communications,  
and Train Control**





## **HSR-3: Laser Optics Communications System**

State University of New York at Stony Brook

### **IDEA Concept and Product**

There is an increasing need for the rapid exchange of large data files between high-speed trains and wayside facilities. One example is the data exchange requirements of communications-based train control systems. These systems, which rely on on-board and central computers, navigation systems, and communications links between trains and central control facilities, require downloading and uploading of large data files such as track and route characteristics, and train-consist data. There are situations when conventional radio communications links may not be the most effective means for such data exchanges because of factors such as data volume, interference, and communications coverage problems.

Another example is the need to exchange health monitoring and diagnostic data for various train components. Increasingly, such data are collected and stored in computers on board locomotives. High-volume train-to-wayside communications links are required to download such data for analysis to provide real-time diagnosis and support the scheduling and management of maintenance and repair activities.

The objective of this IDEA project was to develop a communications system using infrared laser beams and servo-controlled antenna systems to provide high-speed, high-volume data exchange between moving trains and wayside terminals.

The concept uses servo-directed laser beams to provide a communications link between a moving train and a railroad wayside terminal. This technology has the potential to transmit  $10^6$  bytes of information in 0.2 seconds. The servo system would enable the train-mounted and wayside antennas to track each other in the brief period during which the high-volume data exchange occurs. Data communications begin when the train is approximately 30 meters from the wayside terminal, and end at a distance of approximately 10 meters. Tracking of the train and wayside terminals is controlled by servo motors that align photo-optic reflectors based on the strength of the laser signals received.

The contractor, State University of New York, worked with Telephonic Corporation, a commercial communications equipment manufacturer, to determine the most effective strategy for the development and marketing of a production version of this system.

### **Project Progress**

HSR-3 was completed in December 1998. The definition of the requirements and specifications for a laser open-air communications system for high-speed rail application were completed. Prototypes of the train and wayside terminals, including photo-optic assemblies and servomotors, were fabricated and successfully demonstrated in a laboratory environment.

Principal Investigator: Sheldon Chang

Technical Advisor:

Howard Moody,  
Association of American Railroads

IDEA Contract: \$91,024

Cost Sharing \$100,000

Project Total: \$191,024

Start: December 1995

Complete: December 1998



## **HSR-4/ITS-37: Using Rail Vibration Analysis to Detect Approaching Trains**

Raven Inc.  
Alexandria, Virginia

### **IDEA Concept and Product**

The concept is to sense induced rail-vibration signals to detect the approach of trains to warn maintenance crews. IDEA project results indicated that vibration signatures could potentially be used to determine train position, speed, and direction.

CSX Transportation, Inc. and the Washington Metropolitan Area Transit Authority participated in the data collection and field experimentation. A vibration sensor/analyzer showed the potential to detect a train at a distance or to determine that the train is right at the sensor. This attribute led to the design of two different devices that can be used to alert a flagman that a train is approaching. These same devices can be adapted as an inexpensive means of operating a warning system at a grade crossing.

### **Project Progress**

This project was completed February 1997. A follow-on project (HSR-17) was funded to fabricate and test an automatic warning system for track maintenance workers.

Principal Investigator: James Genova

Technical Advisor:

Charles Taylor,  
Association of American Railroads

IDEA Contract: \$73,750

Cost Sharing: \$16,800

Project Total: \$90,550

Start: January 1996

Complete: February 1997

## **HSR-5/ITS-39: Proximity Warning System for Locomotives**

Pulse Electronics, Inc.  
Rockville, Maryland

### **IDEA Concept and Product**

There is growing interest and activity among railroads, suppliers, and government agencies in communications-based train control systems. These systems rely on sophisticated computers on board locomotives and at train control centers, combined with train location and navigation systems, and digital data communications links for the control of train operations. They have the potential to maximize the use of railroad track and equipment and to improve safety and service reliability. These systems would replace the conventional track-circuit based signal systems and allow safe operations with much shorter headways between trains to improve system throughput and increase track capacity. They would also enable the monitoring of train crews for compliance with computer-generated train movement authorities using the on-board computers, and enforce compliance with automatic brake applications.

Most of the systems developed and tested to date have required a significant infrastructure investment, with both trackside and dispatch office hardware and systems. Their highly centralized approach requires implementation on a wide scale and requires a substantial data radio communications system and trackside equipment infrastructure investment.

The objective of this IDEA project was to develop and test a low-cost train navigation and communication system to enable location information to be exchanged between trains on a local area basis. Each locomotive could then compute the distance and relative direction of other trains in its proximity to warn the engineer of potential conflicts.

The proximity warning system is based on the integration of rail navigation and communications subsystems. A rail navigation system on locomotives uses on-board computers, GPS receivers, a gyro, and axle generator interface to determine train location and track ID using an on-board track database. Shared use of the locomotive to end-of-train data communications system provides local area data exchange with other locomotives. Trains periodically broadcast their current track ID, location, direction, speed, and routing plans, which are received by other trains in the area. A color graphics display provides an illustration of the engineer's own train, as well as other trains in the area, against the track profile. The system is able to advise of potential movement conflicts based on comparison of data among trains in the area.

### **Project Progress**

This project was completed in October 1997. Three Burlington Northern Santa Fe (BNSF) locomotives were equipped with prototype systems and tests were conducted in August and September 1997. Radio frequency communications coverage was shown to be sufficient, without need for repeater units. Initial data communications was typically achieved within a distance of about 5 to 6 miles, with consistent coverage within 3 miles. Subsequent to the completion of this project, eight BNSF locomotives were equipped with the system for an expanded pilot project in southern California. These tests were successful. Many of the concepts explored in this project are being incorporated in the design of new communications-based train control products.

Principal Investigator: Robert Kull

Technical Advisor:

Mr. Lynn Garrison, BNSF

IDEA Contract: \$99,000

Cost Sharing: \$120,000

Project Total: \$219,000

Start: March 1996

Complete: October 1997

## HSR-14/27: Multiple Sensor Inertial Measurement System for Locomotive Navigation

Enesco, Inc.  
Cocoa Beach, Florida

### IDEA Concept and Product

There is growing interest and activity among railroads, suppliers, and government agencies in the development of communications-based train control systems. These systems rely on sophisticated computers on board locomotives and at train control centers, combined with train location and navigation systems, and digital data communications links for the control of train operations (see Figure 1). They have the potential to maximize the use of railroad track and equipment and improve safety and service reliability. These systems would replace the conventional track-circuit-based signal systems and thereby allow safe operations with much shorter headways between trains to improve sys-

tem throughput and increase track capacity. They would also enable the monitoring of train crews for compliance with computer-generated train movement authorities using the on-board computers and enforce compliance with automatic brake applications if these authorities are violated.

A key component of such systems is the locomotive navigation system. For the computer system to determine whether the train is in compliance with movement authorities, precise, real-time train location data are required, including identification of which track the train is on. GPS or DGPS alone does not provide the accuracy required, as trains often operate in multiple-track territory with track centers as close as 13 feet. Accordingly, there is a need for a low-cost alternative to conventional rate gyros or laser fiber optic gyros for precise navigation.

The objective of this project was to investigate the use of micro-electromechanical systems (MEMS) accelerometer arrays, combined with GPS, to provide the accurate location of locomotives.

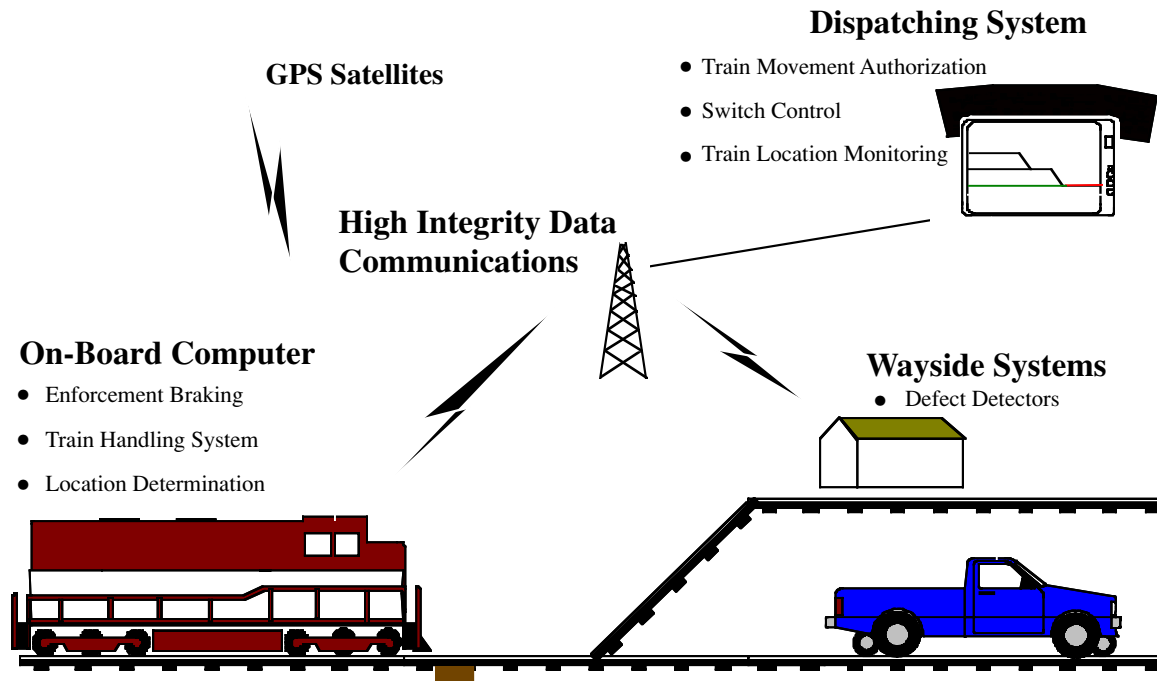

**Figure 1**

*Positive Train Separation (PTS) architecture*

This project examines the possibility of using an array of inexpensive MEMS accelerometers and integrating the accelerometer data with GPS or DGPS data using Kalman filtering techniques instead of the more expensive conventional accelerometers and gyros for locomotive navigation.

## Project Progress

In the first stage of this project the system requirements, initial system architecture, and navigation and Kalman filtering algorithms were developed. Alternative sensor technology was evaluated, and sensors were selected. The sensor system was designed and the system configuration was optimized. A laboratory inertial system using MEMS accelerometers and micromachined gyros was then developed and evaluated. Software was developed for navigation and filtering. An inertial navigation system consisting of four 3-axis MEMS accelerometer modules was installed on the Amtrak 10002 Track Geometry Car and field-tested on the high-speed Washington-to-New-York Metroliner run. The test recorded data from the field navigation system, the laboratory inertial system, and independent higher-resolution sensors. The test data indicate that this system has the potential to provide a low-cost alternative to conventional accelerometers and gyros for locomotive navigation. A final report documenting the system design and test results was completed in March 2000.



**Figure 2**

*Locomotive navigation systems must not only determine train location along a track, but must also detect movement into a parallel track*

A follow-on product application project to develop improvements to the system software and hardware, and install and test a production prototype of the system in a locomotive was recently completed. Project tasks included development of improved navigation and Kalman filtering algorithms, definition of the hardware requirements for the inertial measurement system, and assembly and lab testing of the revised prototype system. These lab tests revealed that the sensor system did not have the required accuracy. ENSCO concluded that it is impractical to base an inertial navigation system for locomotives on existing low-cost MEMS sensors. As a result, no field testing on a locomotive was conducted. A final report was prepared documenting the work accomplished, problems encountered, and recommendations regarding any further research and development of this technology.

Principal Investigator: Fred Riewe

Technical Advisor:

Denny Lengyel, ARINC

Project Panel:

Lt. Laura Kelly, USAF

Ron Lindsey, CSX

Bill Matheson, GE-Harris

Bill Petit, Safetran

IDEA Contract: \$84,961 Initial / \$84,000 Follow-on

Cost Sharing: \$19,865 / \$150,270

Project Total: \$104,826 / \$234,270

Start: June 1998 / June 2001

Complete: March 2000 / June 2004

## HSR-17: Automatic Warning System for Track Maintenance Workers

Raven, Inc.  
Alexandria, Virginia

### IDEA Concept and Product

The safety of track maintenance workers is a vital concern, especially where high-speed trains are operating. These maintenance workers must often rely on a so-called flagman or watchman who is assigned the responsibility of watching for approaching trains, and alerting workers in time to clear all personnel and equipment from the right-of-way before the arrival of trains. This technique is labor intensive and not always effective. Occasionally, those assigned the job of spotting trains do not see them in time to provide adequate warnings. This can, and does, result in fatal accidents and untold near collisions.

As a result of this concern, there is a need to develop a low-cost, reliable, automatic system to provide effective warnings to track workers of approaching trains.

The concept on which this project is based is the detection of train-induced rail vibrations to activate a warning system for track maintenance workers. The application of this technology for train detection was examined in a previous IDEA project (HSR-4). This follow-on project was to develop a warning system that combines the moving train sensor with a robotic signaling and train stop device. Initial application was to be designed for rail transit applications, such as on the Chicago Transit Authority (CTA). Currently, a “slow zone” is established at a track maintenance work site, and a “trip staff” that will automatically stop the train is installed on the tracks. When a train approaches the “slow zone” the flagman sounds a horn to alert the track workers that a train has entered the zone, and signals the train operator to halt with a flag or light. After receiving a track-clear signal from the foreman, the flagman removes the trip staff and signals the train to proceed.

This project was to investigate the feasibility of a robotic signaling device to replace the flagman (Figure 1). The robot would be designed to place and remove the trip staff, and would be under the control of the

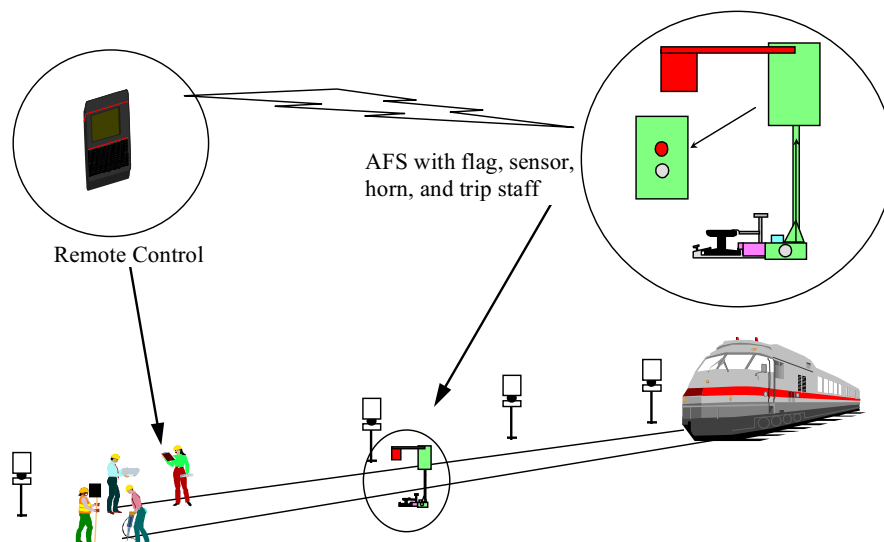

**Figure 1**

*Transit slow zone with automatic flagging system*

track maintenance foreman by means of a hand-held device with a radio frequency link to the robot. The primary objective was to determine whether rail vibration technology could be used to detect the presence and speed of trains approaching track maintenance work zones.

## **Project Progress**

Prototype design drawings for all of the mechanical assemblies were completed. Initial measurements of the acoustic signatures in the rails of approaching trains were analyzed to determine whether approaching trains could be distinguished from background noise from other sources. The next steps were to be the fabrication and preliminary testing of a design prototype. The final stage was to consist of operational testing and evaluation of the prototype on the CTA, and an evaluation of the potential of the concept for high-speed rail applications.

Analysis of the acoustic signature data generated by approaching trains revealed that it was difficult to distinguish between trains and background noise. More-

over, the signatures could likely not be detected far enough down the track to provide adequate warning to track maintenance crews, particularly in territory with high-speed train operations. Consequently, fabrication and testing of a prototype was not undertaken. A report documenting the prototype design and preliminary analysis of the acoustic data was prepared in February 1999.

Principal Investigator: James Genova

Technical Advisor:

Howard Moody, AAR

Project Panel:

Christopher Schulte, FRA

Bea Hicks, WMATA

Alan Lindsey, BNSF

IDEA Contract: \$20,000

Cost Sharing: \$202,000

Project Total: \$222,000

Start: October 1998

Complete: March 2000



## **HSR-18: An Investigation into the Use of Buried Fiber-Optic Filament to Detect Trains and Broken Rail**

Texas Transportation Institute  
College Station, Texas

### **IDEA Concept and Product**

For decades, railroads have relied on track circuits to detect train presence and broken rails. However, track circuitry is expensive to maintain, and does not always reliably detect trains due to such factors as contamination at the wheel-rail interface. Moreover, a substantial percentage of rail breaks occur in which electrical continuity is maintained, and are therefore not detected by the track circuits. This research investigated the feasibility of using fiber-optic filaments buried along the right-of-way to detect trains and to detect the energy released when rail breaks occur. The approach was to use coherent optical time-domain reflectometry (C-OTDR) in concert with advanced signal-processing techniques and neural networks in buried fiber-optic filaments to detect and locate trains and the ballistic event characteristic of rails breaking under stress.

An optical transmission through a continuous length of low-loss, telecommunications-grade fiber buried along the right-of-way, yet away from track maintenance operations, was investigated to determine whether it held any promise for providing an inexpensive, reliable alternative to conventional track circuitry for train presence and broken rail detection. Another potential advantage is that buried fiber-optic filament is free of the problems associated with the electromagnetic interference encountered with track circuits. The objective was a low-cost, reliable alternative to conventional track circuits for near real-time detection and location of rail break events, as well as detection and location of mov-

ing trains that can be commercially developed for application to the railroad. If successful, this technology could also facilitate the railroad industry movement toward communications-based train control systems and away from track-circuit dependent train control.

A state-of-the-art coherent laser is used to pulse a buried communications-grade optical fiber. Information is extracted from polarization shift in the laser pulse backscatter light to establish train presence and rail break events as well as the location and time of events. The laser employs coherent continuous waves with a line width of approximately 10 kilohertz. The laser beam is pulsed at 30 nanoseconds over a 0.1 millisecond period to provide a 2-meter resolution in a 20-kilometer fiber length. The concept was that the system would recognize that a train has stopped by registering the cessation of activity at the last known location.

The system has the potential to continuously monitor train movement, direction, and location while monitoring the track structure for rail breaks. Additionally, the system has the potential to detect and discriminate among various in-train defects, e.g., flat wheels, dragging equipment, and stuck brakes.

### **Project Progress**

The project team developed a coherent laser system and demonstrated its capability to detect very low-energy perturbations on single-mode fiber. Laboratory tests revealed that backscatter is not localized for the event of interest alone, but by all environmental noise along the fiber. The large amount of noise accumulated along the fiber makes the signal of interest, e.g., from a rail break or train, undetectable in fiber lengths in excess of 50 meters. As a result the contractor, Texas Transportation Institute, recommended that the contract be terminated. TTI prepared a final report that documents the work accomplished and the findings.

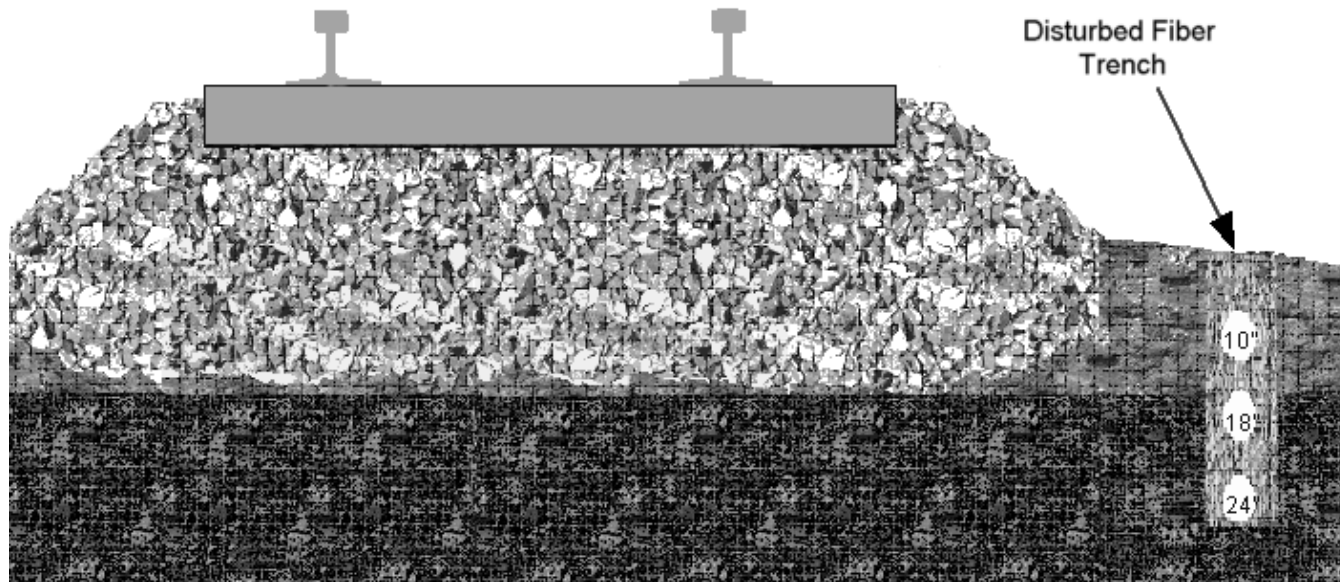

**Figure 1**

*Cross-section of track, ballast, and subgrade with buried optical fiber*

Principal Investigator: Steve Roop

Project Panel:

Henry Lees, Burlington Northern Santa Fe Railway  
James Lundgren, Transportation Technology Center, Inc.  
William Petit, Safetran Systems, Inc.

IDEA Contract: \$60,000

Cost Sharing: \$47,000

Project Total: \$107,000

Start: February 1999

Complete: December 2001



## **HSR-19: Fiber Optical Sensors for High-Speed Rail Applications**

University of Illinois  
Champaign, Illinois

### **IDEA Concept and Product**

This research investigated the feasibility of an alternative to HSR-18 for using fiber-optic filaments to detect trains and broken rail. Rather than using fiber-optic filaments buried along the track structure, this project investigated the application of the filaments directly to the rail. Specifically, the project developed, tested, and evaluated a system employing fiber-optic sensors attached to rail to detect rail breaks and track buckling, and the location and speed of trains. Any break or displacement of the rail, such as would result from a train or rail buckling, would affect the light transmitting characteristics of the attached fiber. This change in the light signal would be detected and analyzed to provide information on the exact location of the train or track defect. The objective is a low-cost, reliable alternative to conventional track circuits for near real-time detection and location of rail break events, as well as detection of rail buckling and location of moving trains that can be commercially developed for application to the railroad. If successful, this technology could facilitate the railroad industry movement toward communications-based train control systems and away from track-circuit dependent train control.

The project investigated alternative types of optical fibers for these applications, optimum location of fibers on the rail, and fiber attachment and removal methods. Other tasks included development of a fiber installation device, development of a computerized optical time-domain reflectometry measurement system, and fabrication and testing of a prototype system.

### **Project Progress**

This project was completed August 2001. The investigation of alternative optical fibers to determine which are best suited for detection of rail breaks, track buckling, and train location and speed revealed that conventional glass fiber has the best combination of low attenuation and low cost. Other optical fibers investigated were polarization-maintaining glass fiber, and plastic fiber. The optimum location of fibers on the rail was determined to be on the vertical surface of the web directly under the rail head. The most promising methods for attachment and removal of fibers was determined, and a rail-mounted cart was developed for installation. The cart automatically applies fiber, epoxy, and a protective tape to the web as it rolls down the rail. A computerized optical time-domain reflectometry measurement system to determine the precise location of rail breaks and track buckling was also developed. A prototype system was installed on test track at the Transportation Technology Center. Tests were conducted and data analyzed to determine the performance of the fibers, attachment methods, algorithms, OTDR system, and the accuracy and reliability of the detection of rail breaks, track buckling, and train location and speed.

Test results indicated that this technology has significant potential, particularly for rail break and track buckling detection. Initial applications of such systems could be on relatively short segments of track at critical locations such as on railroad bridges with the potential for damage from maritime traffic, and in locations with a high potential for track buckling. Widespread application of the technology will require additional development to increase the application speed, lower the costs of application, increase the temperature range within which application can occur, and to protect the fiber from various track maintenance operations. Also, techniques would have to be developed for cost-effective inspection and diagnosis of fibers installed on rail.

Principal Investigator: S. L. Chuang

IDEA Contract: \$95,000

Cost Sharing: \$137,000

Project Total: \$232,000

Start: November 1999

Complete: August 2001



**Figure 1**

*Cart for application of optical fiber to rail*

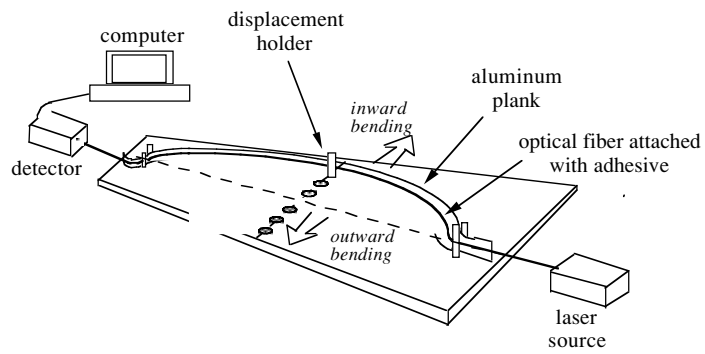

**Figure 2**

*Rail Buckling Experimental Setup*

## HSR-22/35: Low-Cost, Drift-Free DGPS Locomotive Navigation System

Seagull Technology, Inc.  
Los Gatos, California

### IDEA Concept and Product

There is growing interest and activity among railroads, suppliers, and government agencies in the development of communications-based train control systems. These systems rely on sophisticated computers on board locomotives and at train control centers, combined with train location and navigation systems, and digital data communications links for the control of train operations. They have the potential to dramatically increase the utilization of railroad track and equipment and improve safety and service reliability. These systems would replace the conventional track-circuit-based signal systems and thereby allow safe operations with much shorter headways between trains to improve system throughput and increase track capacity. In addition, they would also enable the monitoring of train crews for compliance with computer-generated train movement authorities using the on-board computers, and enforce compliance with automatic brake applications if these authorities are violated.

A key component of such systems is the locomotive navigation system. In order for the computer system to determine whether the train is in compliance with

movement authorities, precise, real-time train location data are required, including identification of which track the train is on. GPS or DGPS alone does not provide the accuracy required, as trains often operate in multiple-track territory with track centers as close as 11.5 feet. Accordingly, there is a need for a low-cost alternative to conventional rate gyros or laser fiber optic gyros for precise navigation.

The objective of this project was to investigate the use of a three-receiver, three-antenna GPS heading reference system, as illustrated in Figure 1. The system includes a low-cost, drift-free highly accurate navigation system hardware design and parallel-track resolution software. A prototype GPS attitude system, that was used to gather field test data, is shown in Figure 2. For robustness, the system is augmented with a low-cost heading gyro and the odometer output from the locomotive. Both the gyro and the odometer are dynamically calibrated by the GPS receiver system, when GPS satellite coverage is available. When GPS satellite coverage is temporarily interrupted, the calibrated gyro and odometer are used to augment the GPS-derived position, velocity, and heading. The parallel-track resolution software takes the train heading and path distance traveled and compares this to a rail database that identifies where turnouts are located. When the train passes through one of these turnouts, the algorithm determines the probability that the train has continued on the original track or has switched onto another track.

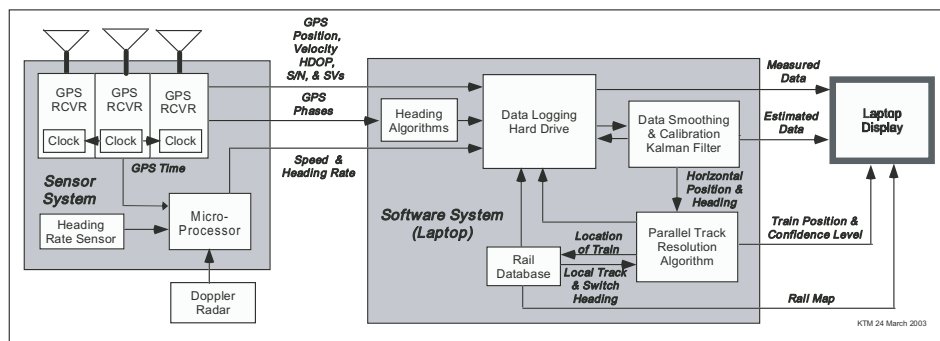

**Figure 1**

*Prototype GLLS Hardware Architecture*

## Project Progress

A prototype system was mounted on a locomotive and a series of tests conducted on the Burlington Northern Santa Fe railroad. Testing was conducted on a main-line and in a large yard. The main line testing was conducted in territory with turnouts and switchovers as well as overhead bridges, tunnels, and other obstructions. Analysis of the test results compared the GPS/DGPS position, velocity, and heading data as well as the odometer and heading gyro data with reference location data from a rail database.

The performance objective for the system required that the passage of a train through a high-speed turnout (number 20 with a 1.75 degree frog angle) onto a siding (with 11.5 foot distance between track centers) can be determined with a confidence level of 0.99999. This

translates into a locomotive heading accuracy requirement of 0.20 degrees (1 sigma) or a lateral position accuracy of 1.3 feet (0.4m, 1 sigma). The measured (unfiltered) GPS heading accuracy was 0.18 degrees (1 sigma). Using either a 6-state or a simple heading 2-state Kalman filter increased the heading accuracy to 0.16 degrees (1 sigma). Since the heading accuracy requirements for the parallel track resolution software is 0.20 degrees, the hardware and software design met the requirements. In addition, using the data collected on a mainline while passing over two number 11 switches (with a 6 degree frog angle) together with the rail database, a confidence level of 0.99999 was demonstrated. Moreover, since Selective Availability (SA) was removed from the GPS signal in 2000, raw GPS position accuracy appears to be sufficient for this application.



**Figure 2**

*Seagull GPS Prototype*



Based on the success of this initial project, the HSR-IDEA Program Committee approved a follow-on project to develop a production prototype of the system. Tasks included development of prototype hardware and software specifications and design to interface the GPS system, a radar speed sensor, and a track data base. The software for sensor calibration and parallel track resolution was refined and a prototype GPS Locomotive Location System (GILLS) fabricated and lab tested. The system was installed on a UP GE C44 AC locomotive and tests run to determine if RF interference from AC traction would affect the performance of the GPS receiver. Tests included accelerations up to 70 mph, dynamic braking, and under full load conditions. No interference was observed.

A three-day field test on Union Pacific in and near Portland, Oregon, was then performed. The system hardware performed well. The accuracy requirements were not met, however, due to such factors as a coordinate system conversion error, inaccuracies in the track data base, and GPS position inaccuracies caused by iono-

spheric delay errors. Post-test adjustments for the conversion and track data base errors substantially improved the accuracy. Seagull Technology has identified software and hardware improvements that should enable the GILLS system to meet all performance requirements. Subsequent to the completion of this project, the FRA contracted with Seagull for further development and applications of GILLS.

Principal Investigator: Tysen Mueller

Project Panel:

Tom Atkins, BNSF Railroad

Jeff Young, Union Pacific Railroad

IDEA Contract: \$94,706 Initial / \$195,089 Follow-on

Cost Sharing: \$50,000 / \$105,000

Project Total: \$144,706 / \$300,089

Start: November 1999 / December 2001

Complete: May 2001 / September 2003

---



**Highway-Railroad Crossing Safety**

---





## **HSR-1/ITS-29: Scanning Radar Antenna for Collision Avoidance**

WaveBand Corporation  
Torrance, California

### **IDEA Concept and Product**

This IDEA product is a compact, low-cost, scanning millimeter wave (MMW) antenna used to detect obstacles and warn of collision risk for both railroads and automobiles. The Spinning Grating antenna system is unique in that it uses the phenomenon of diffraction to define and steer a beam of MMW energy. This technology was first devised for imaging radar systems for aircraft landing guidance.

This IDEA project investigated the potential of using MMW radar with the Spinning Grating antenna to provide surveillance of highway-railroad grade crossings. Scanned microwave radar has the potential to reliably detect the presence of obstacles in the path of a train under a wide range of weather conditions to initiate preventive action.

Millimeter wave sensors are also candidates for providing the raw data needed by intelligent cruise control and collision warning systems for ITS automotive applications. A scanning sensor is needed to provide more complete spatial information about the roadway ahead. Unlike electronically steered antennas and more traditional gimbal-mounted antennas, the IDEA antenna

would likely be inexpensive enough to install in passenger vehicles. The IDEA antenna was chosen by the National Highway Traffic Safety Administration as a candidate for comparative testing to define requirements for collision warning and intelligent cruise control.

### **Project Progress**

This project was completed in February 1997. The California Manufacturing Technology Center, commissioned to develop a low-cost manufacturing approach, found that the antenna can be manufactured primarily of molded plastic with a few metal parts. The antenna has few pieces and can be easily assembled by a multi-axis industrial robot with minimal hand labor. It has just a single moving part.

The findings of this project indicated that the scanning antenna technology had potential for grade crossing surveillance. Accordingly, the investigator received follow-on IDEA project support to test the application of this technology to railroad crossing safety (see HSR-13).

Principal Investigator: Lev Sadovnik

IDEA Contract: \$93,974

Cost Sharing: \$12,020

Project Total: \$105,994

Start: October 1995

Complete: February 1997



## **HSR-2/6: Wide-Angle Video System for Grade Crossings**

Intelligent Highway Systems, Inc.  
White Plains, New York

### **IDEA Concept and Product**

This IDEA project explored the potential of a wide-angle, single-camera machine video system for surveillance of highway/rail grade crossings. Potential uses of such a system would include detecting vehicles on crossings for sequencing four-quadrant gates, detecting stalled or disabled vehicles, and monitoring the performance and condition of grade crossing warning system components. Other uses could be preemption of highway traffic signals to prevent backups onto railway tracks, and detecting and identifying vehicles that trespass railroad tracks after warning systems have been activated.

A single 160° field-of-view, optical surveillance system has been developed that could replace multiple sensors that are presently required to monitor, evaluate, or control the traffic flow within an entire crossing area. Such an area may include each inbound and outbound or exiting lane on both sides of the grade crossing.

The system is also designed to provide real-time detection and tracking of the position of crossing gate arms on each side of the railway tracks, even when a train is present in the intersection. Supplemented with machine vision logic, the system provides potential for the detection of

- objects that are stopped or stuck on the tracks,
- vehicles that are waiting in a queue that extends to within a critical distance of the tracks,
- malfunctioning crossing signals or gates, and
- objects that cross the tracks in violation of crossing signals.

### **Project Progress**

The exploration of this concept for surveillance of an entire, non-orthogonal, omni-directional traffic intersection, rotary, or freeway using a single camera system was the objective of an IDEA project completed in July 1996 (HSR-2). Application for highway-rail grade crossing surveillance was the objective of this follow-on IDEA project (HSR-6). Project tasks included refinement of the system software for application to grade crossings, and field testing on active crossings. The system was designed to monitor the crossing and adjacent roadways and issue predefined alert signals, e.g., when vehicles were detected in the crossing after gate activation, when any crossing warning system malfunction was detected, or if vehicles entered the crossing after the gates were activated.

HSR-6 was completed in December 1997. A prototype system was successfully tested at an active grade crossing on the Long Island Railroad. The contractor, Intelligent Highway Systems, subsequently established a teaming arrangement with Nestor, Inc., another IDEA project contractor (see HSR-19), to examine the use of Nestor's neural network technology for interpretation of the video images.

Principal Investigator: Eugene Waldenmaier

Technical Advisor:

Panos G. Michalopoulos  
University of Minnesota

IDEA Contract: \$44,250

Cost Sharing: \$36,075

Project Total: \$80,325

Start: April 1997

Complete: December 1997

## HSR-8: Microwave Train Detection System for Grade Crossings

O'Conner Engineering, Inc.  
Benicia, California

### IDEA Concept and Product

Despite substantial reductions in accidents at highway-railroad intersections over the past decade, such accidents remain a major cause of fatalities and injuries related to railroad operations. Accordingly, both high-speed and freight railroads, as well as local, state, and federal highway agencies and the Federal Railroad Administration are interested in innovative, low-cost alternatives to conventional grade crossing warning systems. A key component for such systems is the technique for detecting the presence of approaching trains to activate warnings such as flashing lights and gates. Conventional systems rely on the shunting of track circuits by approaching trains for such activation. However, track circuits are expensive to install and maintain, and are not 100% reliable under conditions of rail contamination or light-weight rolling stock. Moreover, as conventional train control systems are replaced by communications-based train control systems, track circuits will no longer be required for activation of train control signals. This has resulted in a search for alternatives to conventional track circuits to detect train presence. The objective of this project is a low-cost, reliable alternative to conventional track circuits for activating grade crossing warning systems.

A state-of-the-art microwave system is used to determine the presence, position, velocity, and direction of movement of trains for activation of highway grade crossing warning systems. The ranging sensor uses frequency modulated continuous wave (FMCW) processing to determine the distance of trains from the crossing (within a frequency range of 24.35 to 24.7 GHz), and Doppler processing to measure train velocity. The ranging sensor has a power output of .005 watts, a range of about 1 mile, and a range resolution of 2 feet. The velocity sensor is a Doppler module radar operating at 24.125 GHz with a power output of .005 watts and a range of 1 mile. It is capable of detecting closing or receding velocities from 0.5 mph up to 150 mph.

The system has the potential to monitor train progress continuously to update the train's estimated time of arrival at the crossing. Variations in train speed are therefore compensated for, and a constant advanced warning time can be maintained. The system can also sense when a train has stopped and the warning system should be deactivated.

### Project Progress

This project was completed in May 2000. O'Conner Engineering developed prototype systems to be evaluated in a series of field tests. A project evaluation panel was convened to review the system design and field test and evaluation plans.

Initial testing of the system was conducted at a single-track crossing on the Kansas City Southern Railroad with a high percentage of stop-and-reverse train movements. A second test series was conducted at a double-track crossing on BNSF that has a mixture of freight and passenger train traffic. Data were collected to evaluate such performance measures as range and train-speed sensor accuracy, trains not detected, false alarm rate, and the accuracy and consistency of advanced warning



**Figure 1**

*Microwave range sensor*

time provided. Event recorders accessed via telephone were installed at the test sites. These event recorders were dialed up and their data downloaded on a daily basis. The data enabled comparisons between the performance of the prototype system and the conventional track circuit system.

Results of these tests identified the need for additional improvements to the system if it is to be used in a full range of crossing configurations and railroad operations. These include earlier detection of high-speed passenger trains due to their lower, more aerodynamic profile. Test results also revealed that applications where extended detection distances are required, e.g., for high-speed trains, and where the tracks approaching the crossing contains curves or other obstructions, require remote radar sensors with radio links to the crossing system. The capability of the system to distinguish among two or more trains in the field of view of the radar sensors was not tested, and may require further development. Subsequent to the completion of this

contract, the contractor continued development of an improved product to overcome these limitations. To date, more than ten of these improved systems have been sold.

Principal Investigator: Joe O'Conner

Technical Advisor:

Janie Page Blanchard

Project Panel:

Ernest Franke, Southwest Research Institute

Fred Perry, MPH Industries

Buck Jones, Kansas City Southern Railroad

IDEA Contract: \$78,500

Cost Sharing: \$23,000

Project Total: \$101,500

Start: April 1997

Complete: May 2000

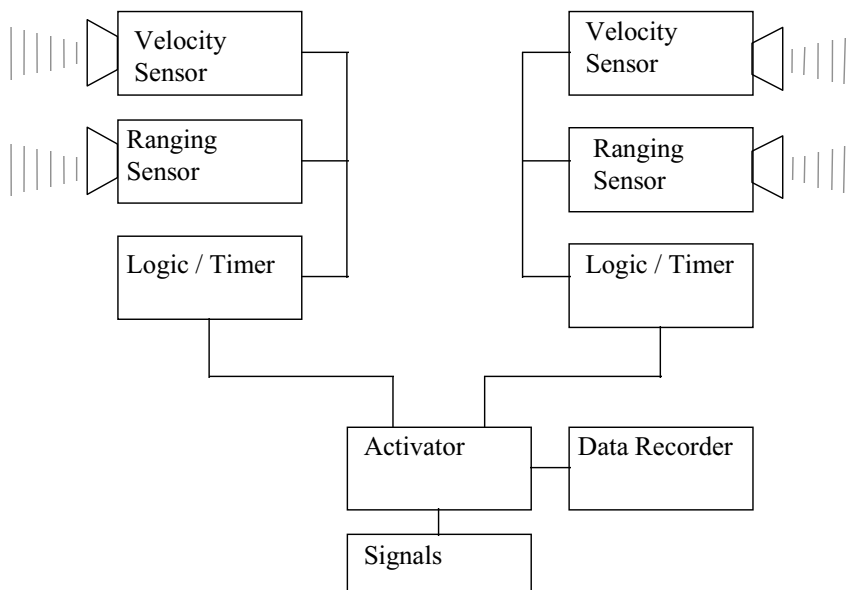

**Figure 2**

*Typical track installation block diagram*

## HSR-10: A Neural Network Video Sensor Application for Railroad Crossing Safety

Nestor Corporation  
Providence, Rhode Island

### IDEA Concept and Product

The introduction of four-quadrant gate systems that block both the entrance and exit of traffic lanes to railroad grade crossings has resulted in the need for information regarding highway vehicles within the crossing area when these systems are activated by approaching trains. There is also a widespread and growing need for a low-cost crossing surveillance system that could observe motorist behavior at crossings and detect the presence of pedestrians and bicyclists in the crossing area; the raised, lowered, or altered condition of crossing arms; and the functional status of signal crossing lights.

The objectives of this project were to determine the feasibility of using video for real-time detection of the presence of vehicles and trains at railway grade crossings, and to monitor crossings equipped with gates and signal lights to determine whether these devices are functioning properly.

This IDEA project developed and tested software necessary to implement a video-based grade crossing surveillance system using a neural network-based video detection technology. The neural network must be able to accurately interpret the objects that move across a grade crossing as well as the condition and functioning of the crossing warning system components. The system could be used for such functions as providing alarm signals to motorists in extreme danger, messages to maintenance personnel regarding damaged or malfunctioning crossing system components, data for assessing grade crossing risk, and enforcement of grade crossing violations.

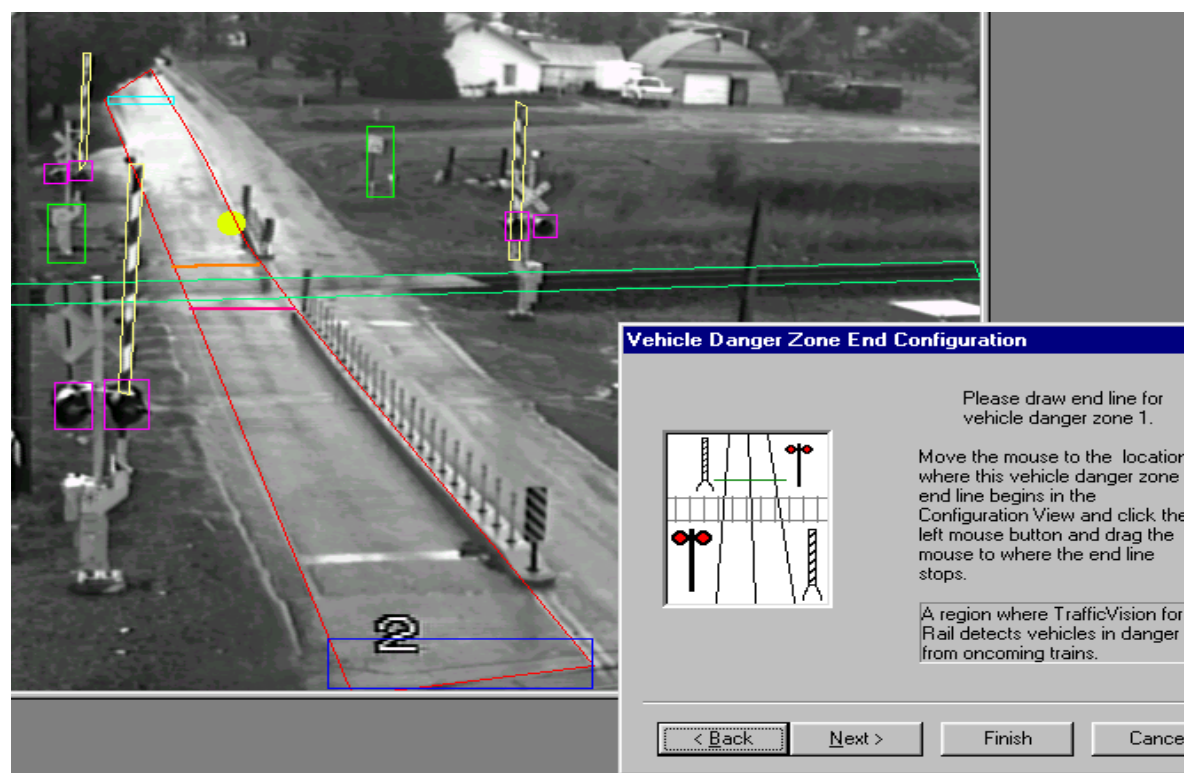

**Figure 1**

*Example of the graphical user interface for initializing the system at each crossing*



## Project Progress

The first stage of this IDEA project involved the definition of specific functional requirements for an automated video surveillance system for grade crossings. The second stage of the project, which concluded at the end of August 1999, consisted of collecting video of grade crossing activity for the purpose of follow-on software development and demo construction. A library of videotapes of grade crossing activity was collected from 9 different crossings in California, Connecticut, Florida, and Washington. Data were collected from single- and multiple-track crossings, crossings equipped with standard gate arms and flashing lights as well as quad-gate arms. Train traffic at the crossings consisted of freight, passenger, and commuter rail service. Video data were collected at different times of day and under different weather conditions (including snow) in order to represent a variety of visibility conditions under which the video sensor capability could be tested.

The final stage of the project included software development to apply the neural network and other image processing technologies to the interpretation of the grade crossing video data as set forth in the project objectives. User interface functionality has been developed to support the system configuration necessary to interpret a grade crossing scene. Software for vehicle, train, and crossing warning system status detection was developed. Specific technical issues addressed included detection accuracy (e.g., incidence of false negatives and false positives), number and configuration of video cameras required, speed of operation and effects of visibility conditions. A desktop demonstration that can showcase the system was developed as part of the final project deliverable.

This system was installed and successfully tested at five crossings in the Ft. Lauderdale area under contracts with the Florida DOT and the Federal Railroad Administration. This project will demonstrate video-based vehicle and train detection, as well as monitoring of the grade crossing warning system (gates and lights). In addition, an enforcement version has been installed at a grade crossing in DuPage County, Illinois. This installation will evaluate the use of the technology for the detection and identification of vehicles that continue through crossings after the warning system has been activated.

In a subsequent contract with FRA, Nestor is developing a mobile surveillance system. The mobile system can be quickly set up at a crossing to monitor such things as highway and train traffic volumes and driver behavior.

Principal Investigator: Doug Reilly

Technical Advisor:  
Ron Ries, FRA

Project Panel:  
Bill Browder,  
Association of American Railroads  
Anya Carroll, Principal Investigator,  
Volpe Transportation Systems Center  
Dennis Hamblett, Washington DOT  
Anne Brewer, Florida DOT,  
Administrator of Rail Operations  
Haji Jameel,  
California Public Utilities Commission

IDEA Contract: \$ 100,000

Cost Sharing: \$ 117,307

Project Total: \$ 217,307

Start: June 1998

Complete: January 2000

## HSR-11: Quad Gate Crossing Control System

Rail Safety Engineering  
Rochester, New York

### IDEA Concept and Product

A major cause of highway-railroad grade crossing accidents is attributed to vehicles driving around the traditional entrance-only crossing gates. As a result, there is great interest in so-called four-quadrant gate systems typically consisting of two pairs of entrance/exit gates providing a complete crossing barrier to prevent drive-around. Existing gate control systems are expensive to modify for four-quadrant gate operation, especially when required to incorporate methods of detecting vehicles stopped on the tracks.

The objective of this IDEA project was a fail-safe, microprocessor-based, application-specific controller that can directly interface to various vehicle detection schemes and will operate exit gate mechanisms and the currently installed entrance gates.

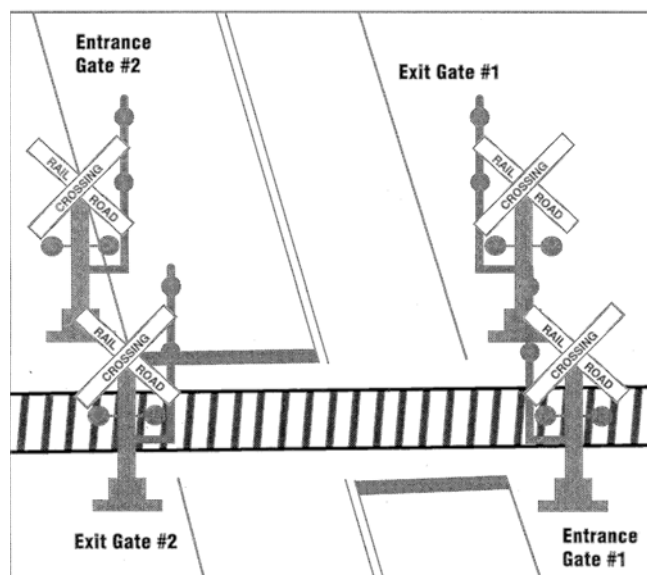

**Figure 1**

*Typical four-quadrant gate system*

This project developed and tested a four-quadrant gate control system based on a novel programmable controller. The product will be an integrated control system consisting of a simulation-design/verification tool, application-specific vital software generator, and solid state vital quad-gate crossing controller hardware. Existing techniques for on-crossing vehicle detection and approaching train detection will be supported to assure that vehicles will be given sufficient train warning and cannot be trapped within the crossing. A software-based application tool set to assist and streamline the design of individual applications of the controller was also developed.

### Project Progress

The project began with the specification of functional and system requirements based on input from potential users of quad-gate crossings. The results were used to develop a high-level system design. Project objectives, approach, and the functional requirements were reviewed by a panel of experts. An external interface specification was completed to describe the interface with crossing surveillance systems. The quad-gate controller is based on a GE-Fanuc Series 90-30 programmable controller. Software requirement specifications and detailed designs have been completed. A prototype system has been fabricated and laboratory tested. The test data were analyzed to assess performance and reliability. Test results indicated that the prototype system met all performance and reliability objectives. A final report documenting the system design and the results of the testing was completed in May 2000.

Subsequent to the completion of this contract, the contractor was bought by GE. GE subsequently bought Harmon, a major railroad signal supplier. The Principal Investigator for this project reported that many of the ideas developed during this project have been incorporated into Harmon's product line.

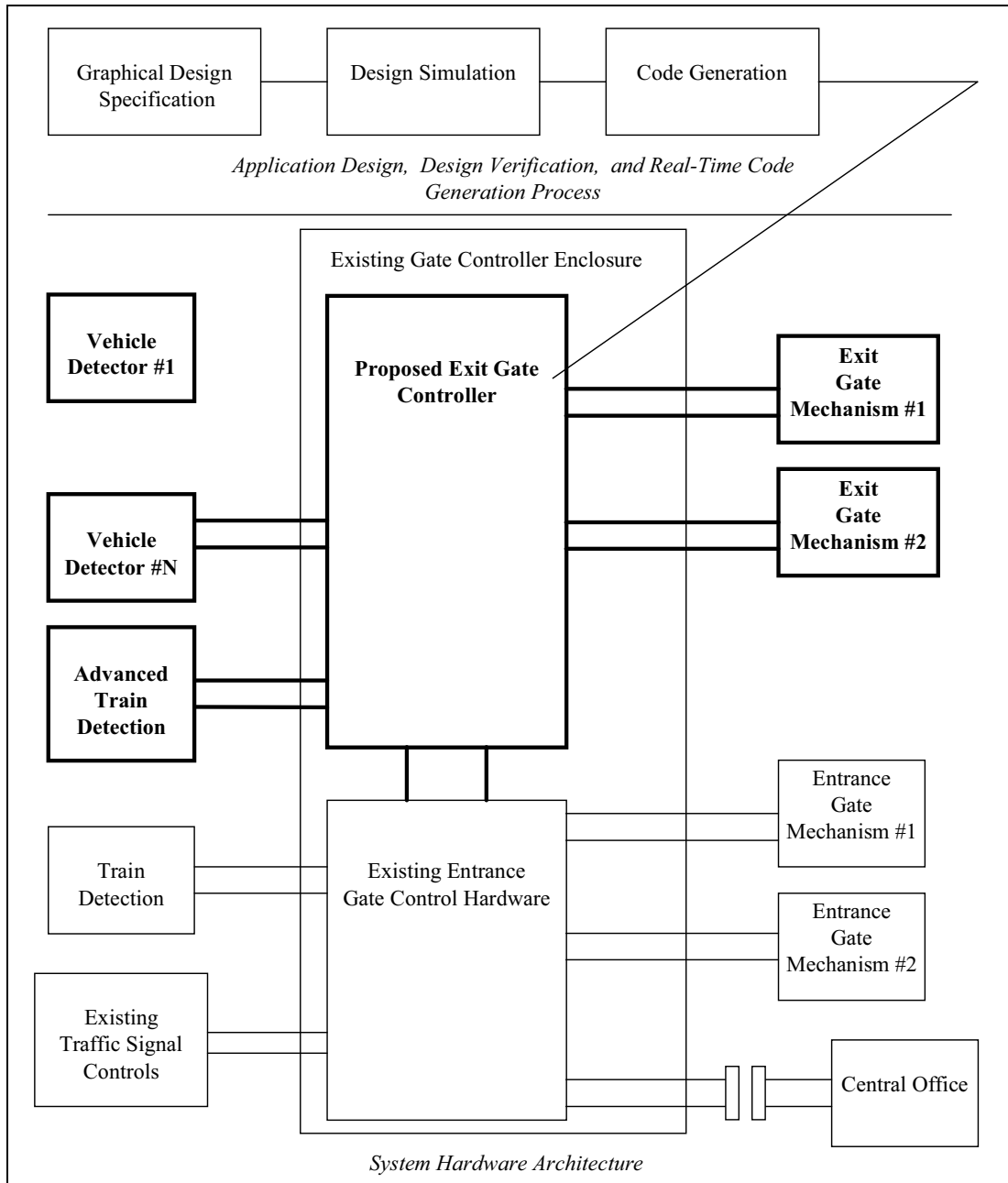

**Figure 2**

*Proposed quad-gate crossing system*

Principal Investigator: Jeff Twombly

Technical Advisor:

Dr. Fred Coleman, University of Illinois

Project Panel:

Dr. Fred Coleman (Chair)

Mr. Richard McDonough, NYDOT

IDEA Contract: \$80,000

Cost-Sharing: \$139,000

Project Total: \$219,000

Start: September 1998

Complete: May 2000

## HSR-13: Grade Crossing Obstacle Detection Radar

WaveBand Corporation  
Torrance, California

### IDEA Concept and Product

There is growing interest in the use of four-quadrant gate systems at railroad grade crossings to prevent motorists from driving around gate arms that block only the entrance lanes to crossings. The introduction of four-quadrant gate systems that block both the entrance and exit of traffic lanes across railroad tracks (see Figure 1) has resulted in the investigation of technologies to provide information regarding highway vehicles within the crossing area when these systems become activated by approaching trains. Such systems could detect vehicles on the tracks to time activation of the exit gate to avoid trapping vehicles between the gates.

The objective of this project was to determine the feasibility of using a millimeter-wave (MMW) radar system to detect highway vehicles within grade crossings. The sensor system would be designed to provide a standard interface with four-quadrant control systems for intrusion detection and sequencing the activation of the exit gates.

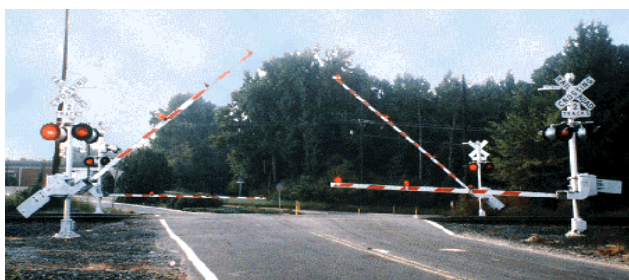

**Figure 1**

*Typical 4-quadrant gate*

WaveBand Corporation has developed a novel scanning MMW radar antenna system (See HSR-1). This system has the potential for use in detecting intrusions in grade crossing areas for automated sequencing of multiple gate arms such as four-quadrant gate systems. The system uses a spinning grating antenna. The narrow-beam scanning antenna provides the spatial resolution required for obstacle detection at railroad crossings. Since the system operates in the MMW frequency band, it should be able to detect objects in adverse weather conditions. The objective was a product that can interface with four-quadrant gate controllers to provide data on vehicle presence in the crossing necessary to sequence gate operation.

### Project Progress

This project (HSR-13) was a follow-on to a previous IDEA project (HSR-1) to investigate the concept of a spinning grating MMW scanning antenna for application to railroad and automotive obstacle detection and collision avoidance (see Figure 2). The follow-on project began with the collection and analysis of information from current and potential users of crossing gates, including four-quadrant gate systems, to develop functional and design specifications for intrusion detection. Design and fabrication of the system hardware and software was then completed. The next steps included labo-

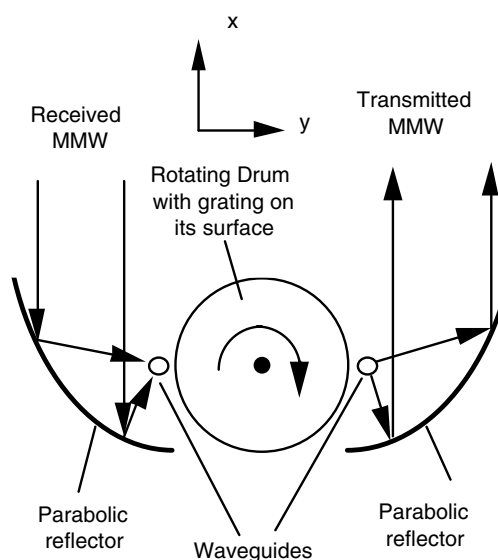

**Figure 2**

*Spinning grating antenna*



ratory shakedown tests followed by preliminary field testing at an active grade crossing. Field test results were promising. Further development of the system will require software to interpret the radar signals and testing under a full range of operating and weather conditions. A final report documenting the system design and the results of the preliminary field testing was prepared in April 2000.

Principal Investigator: Lev Sadovnik

Technical Advisor:

Dr. Fred Coleman, University of Illinois

Project Panel:

Dr. Fred Coleman (chair)

Mr. Richard McDonough, NY DOT

IDEA Contract: \$92,123

Project Total: \$92,123

Start: March 1998

Complete: April 2000

## HSR-16: Advanced Intersection Controller Response to Railroad Preemption

Texas Transportation Institute  
College Station, Texas

### IDEA Concept and Product

Traffic signals that are located near railroad-highway grade crossings are designed to permit vehicles that may be stopped on the tracks to move to safety when a train approaches the crossing. In some cases, the warning time provided to the traffic signal system is as little as 20 seconds before the train arrives at the crossing. Often, the short duration of this warning time can cause crossings to operate in a potentially unsafe and inefficient manner. Further, existing standards, primarily the *Manual on Uniform Traffic Control Devices* (MUTCD), allow traffic signal controllers to cut short the pedestrian phases and vehicle phases that conflict with the track clearance phase. Such heavy-handed preemption treatment, while effective at arriving at the track clearance phase, may leave pedestrians with curtailed WALK and/or flashing DON'T WALK indications

while they are crossing the street, and it may lead to short and confusing signal indications for motorists. This project developed a new method for controller treatment of railroad preemption calls that is based on advanced train detection and controller notification. Detection and preemption systems that are in use today would remain as a fail-safe default preemption where the new strategy, known as the transitional preemption strategy (TPS), is implemented.

The objective of the TPS logic developed and refined during this research was a reliable method for providing improved intersection controller response to the preemption of adjacent highway-rail grade crossings. TPS will ensure that phases that conflict with the track-clearance phase receive the minimum time required for vehicles and pedestrians to clear the intersection; if such time is not available, the phases will never be initiated. The smooth transition into intersection phases that clear vehicles from the highway-rail grade crossing is made possible by advanced detection and warning of the arrival of approaching trains. Placement of advanced train detection devices (Doppler radar) was intended to provide the necessary minimum times for both pedestrians and vehicles on phases that conflict

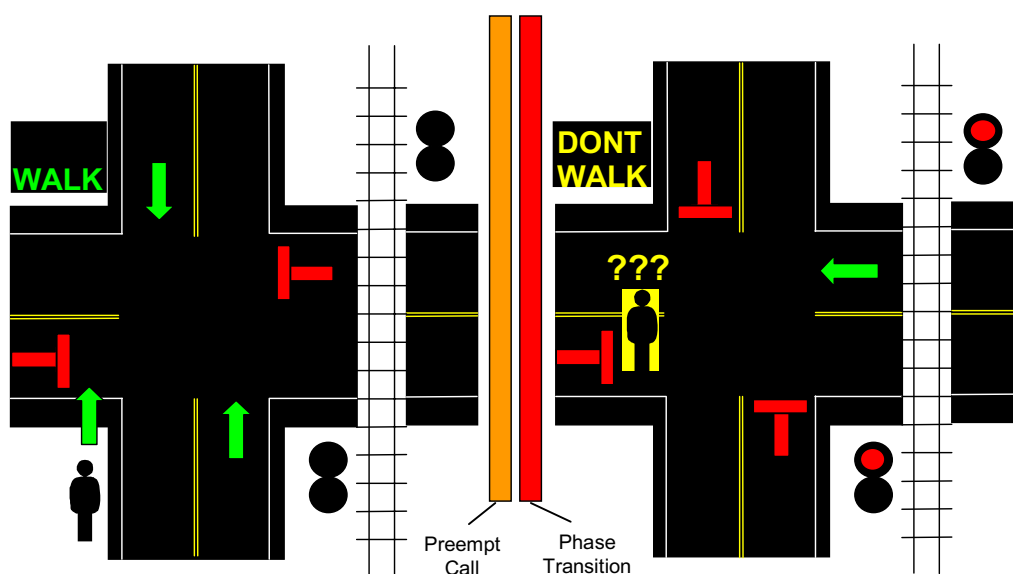

**Figure 1**

*Standard preemption scenario illustrating MUTCD pedestrian “relative hazard” position*

with the track-clearance phase before it is initiated. The fact that TPS avoids the display of short green indications for motorists at the intersection can also lead to operational improvements in terms of the intersection's ability to smoothly and safely process vehicles.

## Project Progress

Development of the TPS logic was organized into three stages. During Stage I, researchers at the Texas Transportation Institute (TTI) synthesized background research and current practice pertaining to railroad preemption of traffic signals near highway-rail grade crossings. Once this was completed, the TPS logic algorithm was developed.

Stage II of the research had as its primary objective the simulation testing of the TPS logic. The TPS algorithm was software encoded and integrated into a unique simulation and testing environment with the staff support and hardware of TTI's TransLink® research laboratory. The testing environment, known as hardware-in-the-loop simulation, allows a traffic and/or traffic and highway-rail grade crossing simulator to be connected to an actual traffic signal controller device. A piece of electronic hardware known as a controller interface device connects to the controller's standard input/output con-

nectors and to a PC's USB port, allowing the use of the traffic signal controller's functionality for traffic control and preemption for vehicles, pedestrians, and trains simulated on the PC. During the testing and simulation stage, the logic was refined and improved. The results of the simulation effort included a side-by-side comparison of results from cases that did and did not include the TPS logic.

Stage III of the project, which included field-testing of the algorithm at a signalized intersection adjacent to a grade crossing, was completed. Advanced train detection information at the field site was obtained using TTI TransLink's Doppler train-detection equipment and train arrival-time estimation software.

Results of the field testing revealed substantial variability between predicted and actual arrival of trains at crossings. This problem was because the Doppler radar system made only a single-point estimate of train speed for predicting crossing arrival times. This estimate did not account for any subsequent acceleration or deceleration of trains. Further development of this concept would require the capability for frequent updates of train speed and arrival predictions. A final report documenting the algorithm, system design, and test results was completed in February 2000.

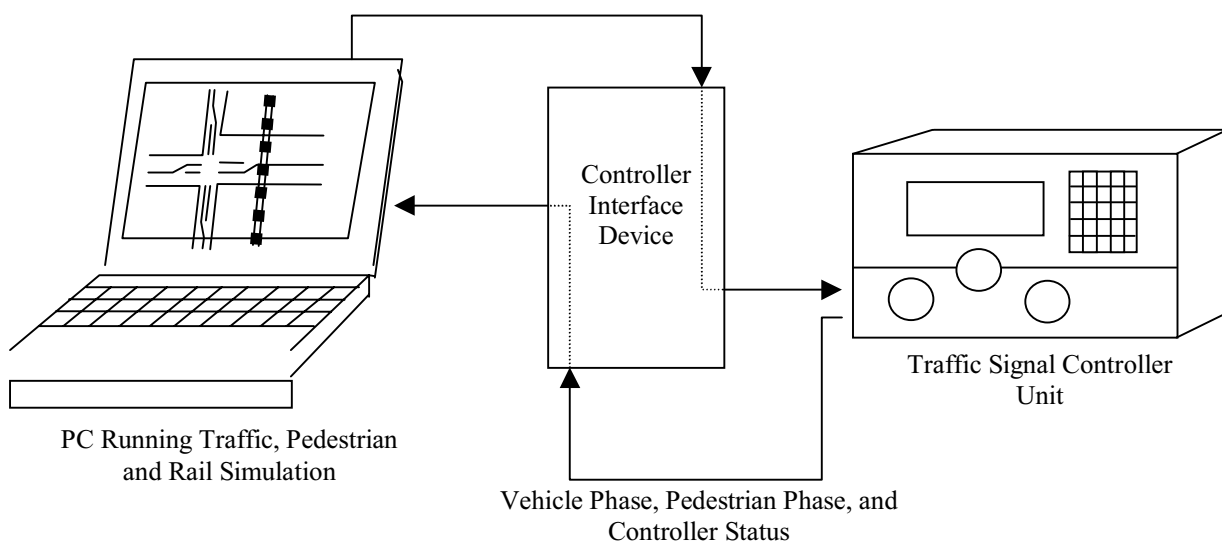

**Figure 2**

*Simulation environment for transitional preemption strategy development and testing*

---

This project led to the development of a training course on railroad preemption techniques. The contractor, Texas Transportation Institute, is now giving this course to state and local transportation engineers.

Principal Investigator: Steve Venglar

Technical Advisor:

Hoy Richards, Richards and Associates

Project Panel:

Cliff Shoemaker, Union Pacific Railroad

Arnold McLaughlin, Eagle Traffic Control  
Systems

Mark Smith, City of College Station, Texas

IDEA Contract: \$65,000

Cost-Sharing: \$15,310

Project Total: \$80,310

Start: February 1999

Complete: February 2000



---



## Track and Structures

---





## HSR-15/28: Hybrid Uni-Axial Strain Transducer

University of Utah/University of Iowa

### IDEA Concept and Product

The collection and analysis of data on the fatigue history of high-speed railroad components such as rail, bridge members, and wheels is extremely difficult using traditional sensors and data acquisition systems. Strain-gauge systems typically require cumbersome data collection, preprocessing and storage devices, signal processing devices, substantial power sources, and complex wiring. And these systems do not provide high resolution and are not drift free. Uni-axial and bi-axial strain transducers are micro-electromechanical systems (MEMS) with such characteristics as high resolution and high sampling rate, absolute encoding, no calibration requirements, no drift over time, and less measurement noise than analog-based strain sensors. They measure strain by measuring the displacement between two overlapping pads attached to a structure such as a beam or rail. One pad contains an array of electrostatic field emitters, and the other pad contains an array of field effect transistor gates on an IC chip. Displacement of one pad relative to the other pad causes the emitters to move over the surface of the IC chip. Digital processing of the resulting signal is used to calculate strain.

The system can measure displacements as small as 50 Angstroms ( $5 \times 10^{-7}$  cm). The sensor sampling rate is dynamically configurable and up to 128 sensors can be linked on a common 5-wire digital bus, eliminating the need for shielding and considerably reducing the number of wires which have to be routed through the structure to be measured. Because they have low DC power requirements, they can be used in remote locations. The small size and on-chip signal processing features provide the potential for a truly portable testing device.

The objective of this research was to determine the potential of these transponders as a new tool to continuously monitor, analyze, and store the strain history of components such as rail. This data could be periodically downloaded and used for such purposes as measuring rail stress induced by axle loadings or thermal loadings. The research was to develop a prototype transponder system, which includes nonvolatile RAM to store strain cycling history, e.g., tracking how many times the transponder crosses each of specified strain thresholds across its dynamic range, and temporarily storing the preprocessed data. The prototype system consists of three parts, a sensor, a networking controller box, and a communication cable. Figure 1 shows a schematic design of a hybrid uniaxial strain transducer (HUAUST) controller to be operated by a battery. A load

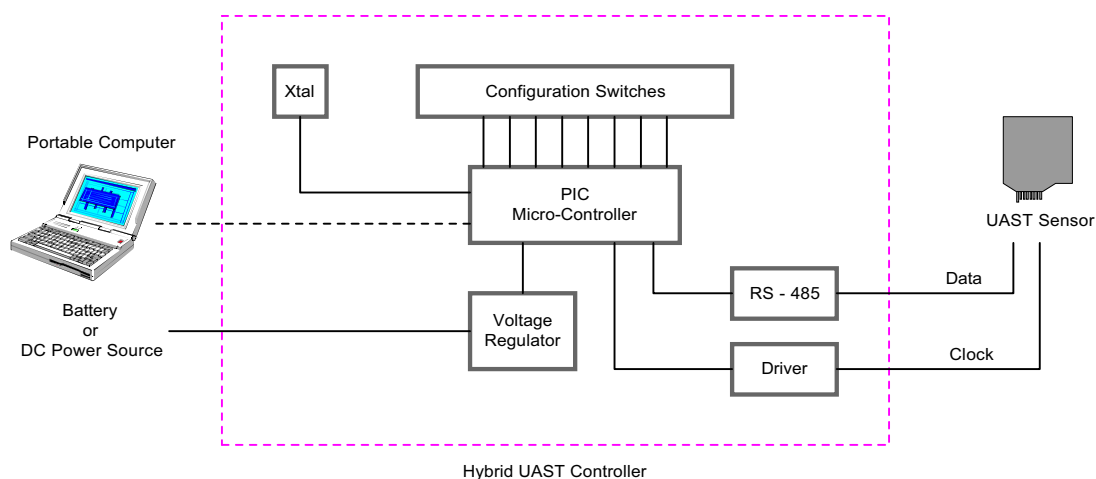

**Figure 1**

*Schematic diagram of a prototype Hybrid UAST*

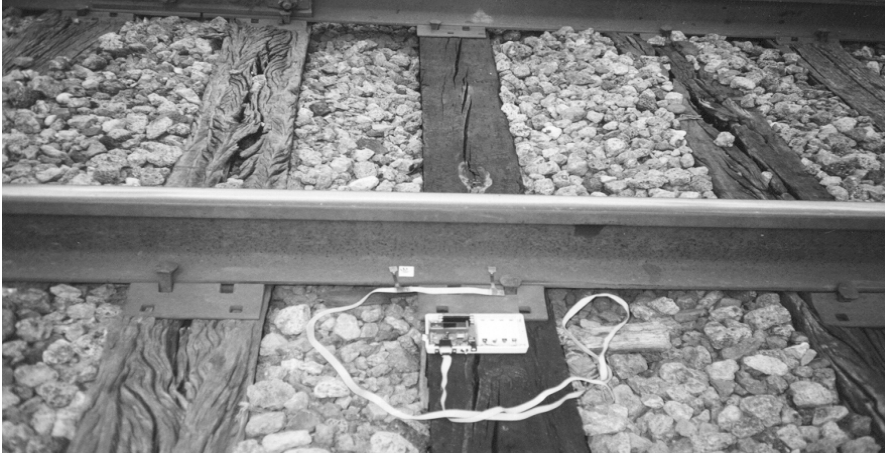

**Figure 2**

*Strain data collection from a rail using UAST™ and a microcontroller*

cycle counting algorithm is integrated into a microcontroller, which is programmable using configuration switches. Using this HUAST controller, eight different strain levels can be collected at four different sampling rates.

## **Project Progress**

Laboratory tests using an aluminum beam equipped with UASTs and conventional foil strain gauges demonstrated the accuracy and repeatability of the UASTs. A series of cyclic loading tests was performed to simulate a moving trainload applied on a rail using an MTS loading machine in the laboratory. The main purpose was to determine an optimum sampling rate for rail. A technique for mounting the HUAST to rail was developed. A prototype HUAST design and load cycle counting algorithm were developed and tested using actual HUAST strain data taken from a rail section at a field test site on a railroad in Salt Lake City. A prototype HUAST package was fabricated and laboratory tested. Field testing of the HUAST prototype package in a rail operating environment was conducted, and analysis of the test data completed. A final report documenting the system design and test results was completed in March 2000.

This concept exploration project was sufficiently successful that a follow-on contract was awarded to develop and build a production prototype system based on this concept, and test it at the Transportation Technology Center, Inc. (TTCI). The prototype system used bi-axial strain transducers, which can simultaneously measure strains in two directions, rather than the previous uni-axial transducers. Tasks included development of a model to predict rail fatigue life, and a network of five bi-axial strain transducers was constructed for use in field tests at TTCI. Initial field tests indicated the need for further improvements to the prototype. Problems were encountered with attaching the bi-axial sensors to the rail, only two of the five sensors functioned, and none of the sensors proved to be accurate and reliable. The manufacturer of the bi-axial strain transducers was unable to finish the development of a final prototype system. Accordingly, the University of Iowa project team attempted to finish the prototype system and to analyze and correct the problems encountered in the initial field tests. They were unable to successfully resolve the problems with mounting the sensors on the rail and in determining the causes of the unreliable sensor performance. For that reason, a planned second series of tests at TTCI had to be cancelled. The University of Iowa team prepared a final report that documented the work accomplished and the problems identified.

---

Principal Investigator: Hosin Lee

Technical Advisor:

James Lundgren,  
Transportation Technology Center, Inc.

Project Panel:

David Warnock, Utah Transit Authority  
Crosby Mecham, Utah Transit Authority  
Rick Campagna,  
Utah Department of Transportation

IDEA Contract: \$45,000 Initial / \$145,000 Follow-on

Cost Sharing: \$20,000 / \$60,000

Project Total: \$65,000 / \$205,000

Start: November 1998 / January 2001

Complete: April 2000 / September 2004

## HSR-23/43: Investigation of a Hybrid-Composite Beam System

Teng & Associates, Inc.  
Chicago, Illinois

### IDEA Concept and Product

Many of the railroad bridges in the United States were built in the early 1900s or before. Time and tonnage have taken their toll on these structures, and railroads today are confronted with the necessity to replace them or upgrade them with selective replacement of critical

components. The objective of this project is to develop a cost-competitive alternative to conventional steel or reinforced concrete beams that would be lighter in weight and resistant to corrosion. The concept to be explored is a composite structural beam system using both plastic and concrete components.

The beam system consists of three main components. The first of these is the plastic beam shell that encapsulates the other two components. The second component is the compression reinforcement that consists of a portland cement grout or concrete arch that is pumped or pressure injected into a continuous conduit fabri-



**Figure 1**

*Cut-away view of hybrid composite beam system*

cated into the beam shell. The third component is the tension reinforcement that is used to equilibrate the internal forces in the compression reinforcing. This tension reinforcing could consist of unidirectional carbon or glass fibers or steel fibers anchored to the ends of the concrete arch.

## Project Progress

Project tasks included a life-cycle cost comparison of a generic hybrid-composite beam system with conventional steel and reinforced concrete beam systems. Costs related to manufacturing, installation, and maintenance and inspection were compared. Research to identify the materials most suitable for hybrid-composite beam fabrication, including best fiber and matrix composition, concrete mix designs and tension rein-

forcement materials was performed. A hybrid-composite beam system was designed based on such criteria as bending shear, live-load deflections, and fatigue. An analysis of the proposed design using mathematical models was performed and design modifications made based on results of these analyses. A 19-foot scale model prototype of the beam system was designed and fabricated. Tests of the prototype beam system were conducted, and test data compared with mathematical model predictions. Findings indicated that bridges constructed with the hybrid-composite girders would have the same strength and stiffness characteristics as bridges constructed using steel or prestressed girders, but would offer greater corrosion resistance and increased load-carrying capacity at a competitive cost. A follow-on product application contract was then awarded to construct 30-foot full-scale prototype beams and subject



**Figure 2**

*Three-point load testing of a prototype beam at University of Delaware's Center for Composite Materials*



them to additional laboratory tests and also test them in a railroad operating environment. This contract will include field testing in a bridge at the Transportation Technology Center in Pueblo, Colorado, where the prototype will be subjected to repeated loads by test trains with heavy-axle cars. The first beam is being tested in the lab, where it is being subjected to a 2-million cycle load test using hydraulic actuators. This contract is being jointly funded by the HSR-IDEA and the NCHRP Highway IDEA programs.

Principal Investigator: John Hillman

Project Panel:

Gregg Blaszak, BG International  
Mark Kaczinski, The D.S. Brown Company  
Paul Markelz, Bridge Technology, Inc.  
Ifiran Oncu, Amtrak

IDEA Contract: HSR 23: \$99,931 / HSR 43: \$240,557

Cost Sharing: \$14,267 / \$214,834

Project Total: \$114,198 / \$455,391

Start: August 2000 / September 2003

Complete: August 2002 / March 2005 (est.)

## **HSR-24/41: Improved Reliability of Thermite Field Welds**

University of Illinois  
Champaign, Illinois

### **IDEA Concept and Product**

Failures of field-welded rail joints are a significant cause of derailments in the North American railroad industry. As such, they contribute significantly to train delay and have a major impact on rail service reliability. The increasingly heavy axle loads characteristic of current and future railroad freight operations will only make this problem worse. Moreover, since most high-speed passenger operations are on track shared with heavy-haul freight operations, the search for improvements in field weld technology is important to both freight and passenger operators.

This project investigated techniques for improving the fatigue performance of thermite welds by diminishing the likelihood of initiating fatigue cracks in two critical locations: the rail web and the rail base. Cracks develop at the weld toes in these locations (Fig. 1) because of local geometric discontinuities (notches). The project investigated new designs to improve the local notch-root geometry of welds, and new types of sealant between the rail and the mold used in thermite welding that will produce smoother surfaces in these fatigue-critical notch-roots. Alternatives to the currently used fluxes and techniques to coat the interior weld molds to produce a smoother cast surface were also investigated.

At the conclusion of the project recommendations were developed to alter the equipment, materials, and techniques used by track maintenance personnel when they perform thermite welding in the field.

### **Project Progress**

Methods of modifying thermite weld molds to reduce the severity of the weld profile of the base and web regions were developed. Mold washes and fluxes to coat the interior of weld molds to produce a smooth cast surface were studied. Techniques and materials to seal the mold against the rail were investigated. Full-size thermite welds were fabricated using modified molds with improved weld geometries and internal coatings and using mold to rail sealants (Fig. 2). A test fixture for 4-point bend tests of thermite welds was constructed and fatigue tests were performed on the fabricated weldments. Modifications of weld molds produced welds that extend the fatigue life of thermite welds 2 to 5 times beyond that of normal thermite welds. Specific improvements were reducing the flank angles and increasing the weld toe radii.

Based on these findings, the HSR-IDEA Committee recommended a follow-on contract with the University of Illinois (UI) to investigate additional methods to improve thermite welds and conduct more extensive testing. These include methods to reduce the surface roughness of weld metal and tighter control over the thermal conditions during welding. A major supplier of thermite welding equipment provided samples of its current welds and welds based on the UI-developed new designs.

Extensive laboratory testing indicated that the improved welds had an average fatigue life approximately 2.5 times longer than that of standard welds. In-track field testing of both standard and improved welds were to be conducted at the Transportation Technology Center in Pueblo, Colorado. However, a fabrication fault in the web resulted in termination of the tests. These flaws have been corrected and a long-term field testing program is scheduled to resume in early 2005.

Principal Investigator: Fred Lawrence

IDEA Contract: HSR-24: \$89,929 / HSR-41: \$155,894

Cost Sharing: \$69,699 / \$38,832

Project Total: \$159,628 / \$194,725

Start: July 2000 / January 2003

Complete: April 2002 / September 2004

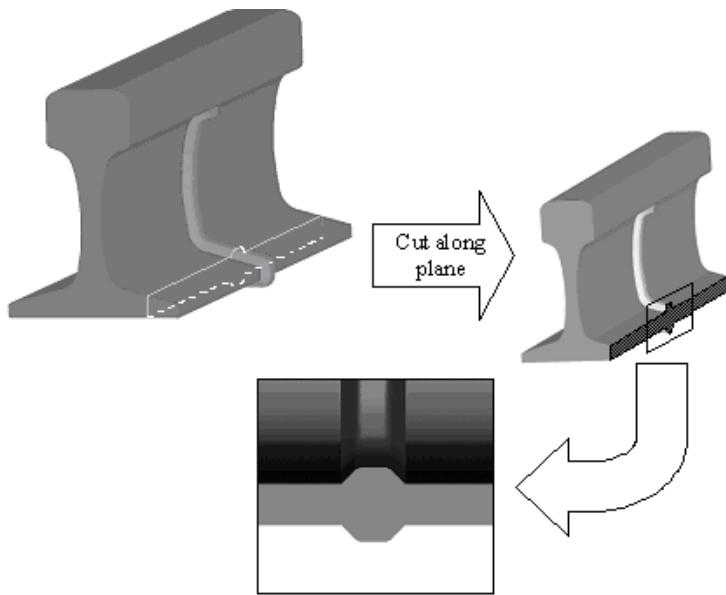

**Figure 1**

*The thermite rail-weld weld-toe. Section of a thermite weld in the rail base. The circled regions are at weld-toes.*



**Figure 2**

*Thermite welding in the Newmark Structural Engineering Laboratory at the University of Illinois at Urbana. Personnel from the CNIC railroad are present to ensure industrial practice.*

## HSR-25: Neural-Network Based Rail Flaw Detection Using Unprocessed Ultrasonic Data

University of Illinois  
Champaign, Illinois

### IDEA Concept and Product

Field inspection to detect rail flaws is performed primarily using ultrasonic transducers mounted on track-mounted vehicles (see Figure 1). Failure to promptly detect and repair these flaws imposes service reliability problems for both freight and passenger operations, and can pose safety concerns. Current ultrasonic rail flaw detection technology limits inspection vehicle operating speeds to about 15 mph and detects only about 70 percent of the flaws. Both of these restrictions result

from the limitations of the human operator's ability to interpret the signal from the detection equipment. When flaws are indicated with the current system, it is often necessary to stop the inspection vehicle and perform a hand test. This limits efficient management of rail repair and delays traffic.

Neural networks have the potential to substantially enrich the capability to efficiently and reliably extract comprehensive information from the ultrasonic signal used to inspect rail, and to do so in a more automated manner. Neural networks can improve the capability to recognize flaws using the ultrasonic signal after it has been filtered by the signal processor. However, the information in the processed signal is substantially abridged because of limitations in the human operator's ability to interpret it, and much useful information about flaws is discarded.



**Figure 1**

*Rail flaw inspection vehicle*



In this project, laboratory and field techniques were to be used to develop neural networks that use all of the information, not just the processed signal. The end product envisioned was a rail inspection car that can operate at significantly higher speeds, detect flaws earlier and more reliably, and detect flaws that currently cannot be detected.

## Project Progress

A rail flaw detection laboratory was planned to generate and record data under controlled laboratory conditions, and to perform verification tests during the development of the neural network systems. Ultrasonic inspection data were then to be generated and recorded under controlled conditions in the laboratory. These data were to be used in the development and verification of the neural network system.

Sperry Rail in Danbury, CT had initially agreed to generate and record inspection data under controlled conditions in the laboratory to be used in the development and verification of the neural network system. The sys-

tem was then to be subjected to a series of tests at Sperry's facilities, and revised as necessary. After the project began, Sperry reported that it could no longer support the project. Because Sperry's support was essential, the contract was terminated. The project team prepared a final report that included the concept and application, the intended investigative approach, work performed, and recommendations for any future investigation of this idea.

Principal Investigator: Jamshid Ghaboussi

Technical Advisor:

Tom Wright, BNSF RR

IDEA Contract: \$90,000 Revised to \$40,000

Cost Sharing: \$85,000

Project Total: \$175,000

Start: September 2000

Terminated: July 2003

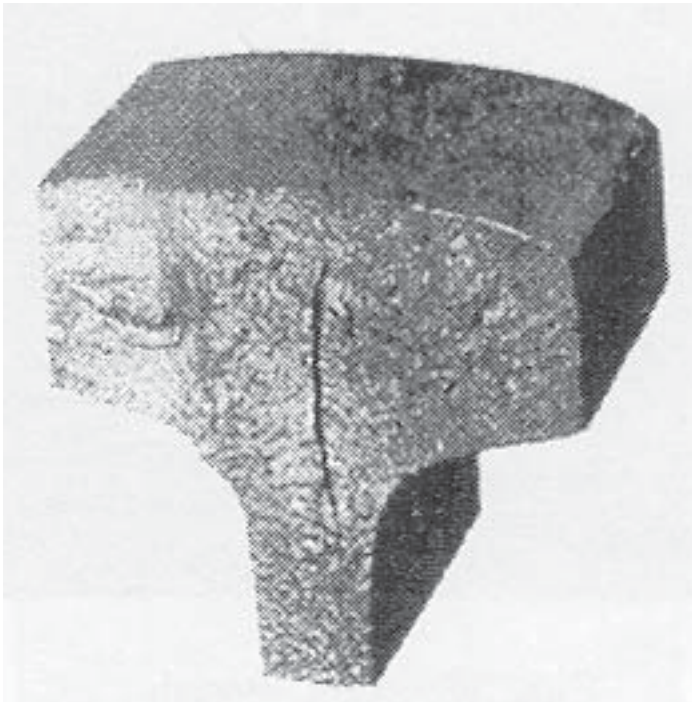

**Figure 2**

*Rail cross section showing vertical split. The objective of this project is more reliable and efficient detection of such flaws.*

## **HSR-26: High-Precision GPS for Continuous Monitoring Of Rail**

University of Illinois  
Champaign, Illinois

### **IDEA Concept and Product**

A fast, precise, low-cost method for predicting conditions that can lead to track buckling or rail breaks is a high-priority research need in both the freight and high-speed passenger railroad industries. One precursor of such events is minute changes in track geometry. These can result from temperature-induced longitudinal stress that begins to exceed the capacity of the lateral restraint system (e.g., spikes, ties, ballast). This project was to develop, test, and evaluate a high-precision GPS (HPGPS) system for monitoring minute changes in rail geometry, and assess the likelihood that these changes can be used to reliably estimate rail stress and predict incipient rail buckling and rail breaks. Precise measurements of small changes in rail geometry (2-3 cm) using HPGPS, combined with data on current and laying temperature for the rail, would be used to calculate rail stress and predict the likelihood of buckling or breaks. In addition to predicting such potentially catastrophic events, such a system could be used to pinpoint track locations where maintenance is required, as determined by geometry changes due to such causes as changes in track bed conditions and rail anchoring. If this concept is viable, such a system could be used on locomotives and/or track inspection vehicles.

### **Project Progress**

Kinematic differential GPS data were collected on a railroad in both warm and cold weather conditions. The data were collected by mounting a DGPS system on a

highway-rail inspection vehicle and were then analyzed using previously surveyed benchmark points along the test section of track. Software was developed for a track monitoring system based on the HPGPS data.

The findings of the investigation were that (a) rail movement prior to a buckle or break is probably too small to detect, and (b) the requirements for repeatable, high-accuracy measurements (2-3 cm) of rail movement could not be achieved. This was due to inaccuracies in the HPGPS system attributable to such factors as inadequate integer cycle ambiguity resolution, and to the loose coupling between the HPGS system and the rail. Literature reviews and interviews revealed that buckles and breaks often occur under trains and are not usually preceded by measurable lateral movement. Accordingly, it is unlikely that an HPGPS system mounted on a rail inspection vehicle could reliably detect an incipient buckle or break. Other potential applications, such as detection of small lateral movement of rail caused by subgrade movement, would require improvements in the accuracy of HPGPS systems.

Principal Investigator: David Munson

Project Panel:

Jeff Baker, GE Transportation Systems  
Evan Jacobson, Rockwell Collins  
Mike Roney, Canadian Pacific Railway  
Randall Walker, Cedar Rapids and Iowa City RR

IDEA Contract: \$100,000

Cost Sharing: \$18,360

Project Total: \$118,360

Start: July 2001

Complete: September 2003

## **HSR-30/48: Vibration Measurements of Rail Stress**

University of Illinois  
Champaign, Illinois

### **IDEA Concept and Product**

A reliable, low-cost, easy-to-use technology for measuring longitudinal stress in rail continues to be a high-priority objective for both freight and passenger rail operators. The fact that three other HSR-IDEA projects are addressing this need (HSR-15/28, HSR-19, and HSR-26) is evidence of its importance. The effects of thermal expansion and contraction and train forces can produce tremendous stress in rail; especially long strings of welded rail. Various rail-anchoring systems are used to prevent these stresses from pulling or pushing the rail out of alignment, or breaking it. These stresses can occasionally exceed the capabilities of the anchoring system and/or the strength of the rail, resulting in rail

breaks or buckling, which continue to be significant causes of derailments and train delays (Figure 1).

These two projects are to evaluate “vibro-elastic” methods for measuring longitudinal stress in rails. This concept is based on the known sensitivity of bending vibrations to contained longitudinal stress. The rail is excited at a specified frequency using an electromagnetic shaker. A laser vibrometer that is scanned along the rail is used for dynamic displacement measurements to determine the frequency and wavelength of the resulting rail vibrations (Figure 2). The resulting wavelength, along with the rail rigidity (which can be determined by the rail dimensions and modulus) can be used to determine contained longitudinal load.

### **Project Progress**

Tasks completed include development of a wave number categorized by rail shape and frequency, and development of a numerical simulation of the effect of longi-



**Figure 1**

*Rail buckling caused by thermal expansion*

tudinal load on guided waves, including a study of the propagation of errors. Laboratory tests with the rail under no load and under longitudinal loads up to 100 kips using a hydraulic actuator were conducted. Field tests were then conducted and the results compared with data from strain gages attached to the rail. A follow-on contract with University of Illinois for additional development of the concept began August 2004. The contract work includes development of a more robust laser spot positioning system, an improved scan platform that will allow faster scans, more convenient calibration procedures, a method to accommodate variations in rail profiles, and techniques to mitigate the effects of intermittent structural changes in the track system that occur while measurements are being taken. The improved system will then be subjected to laboratory tests and field testing on a railroad. A new, faster scan platform and loading rig have been developed and used in lab studies on new 136-pound rail. Tests on worn rail and other rail sizes are under way.

Principal Investigator: Richard Weaver

Project Panel:

Keith Hjemsted, University of Illinois  
Hayden Newell, Norfolk Southern RR  
Martin Schroeder, TTCI

IDEA Contract: \$99,960/ \$130,000

Cost Sharing: \$48,000/ \$60,000

Project Total: \$147,960/ \$190,000

Start: April 2001/ August 2004

Complete: April 2004/ March 2006

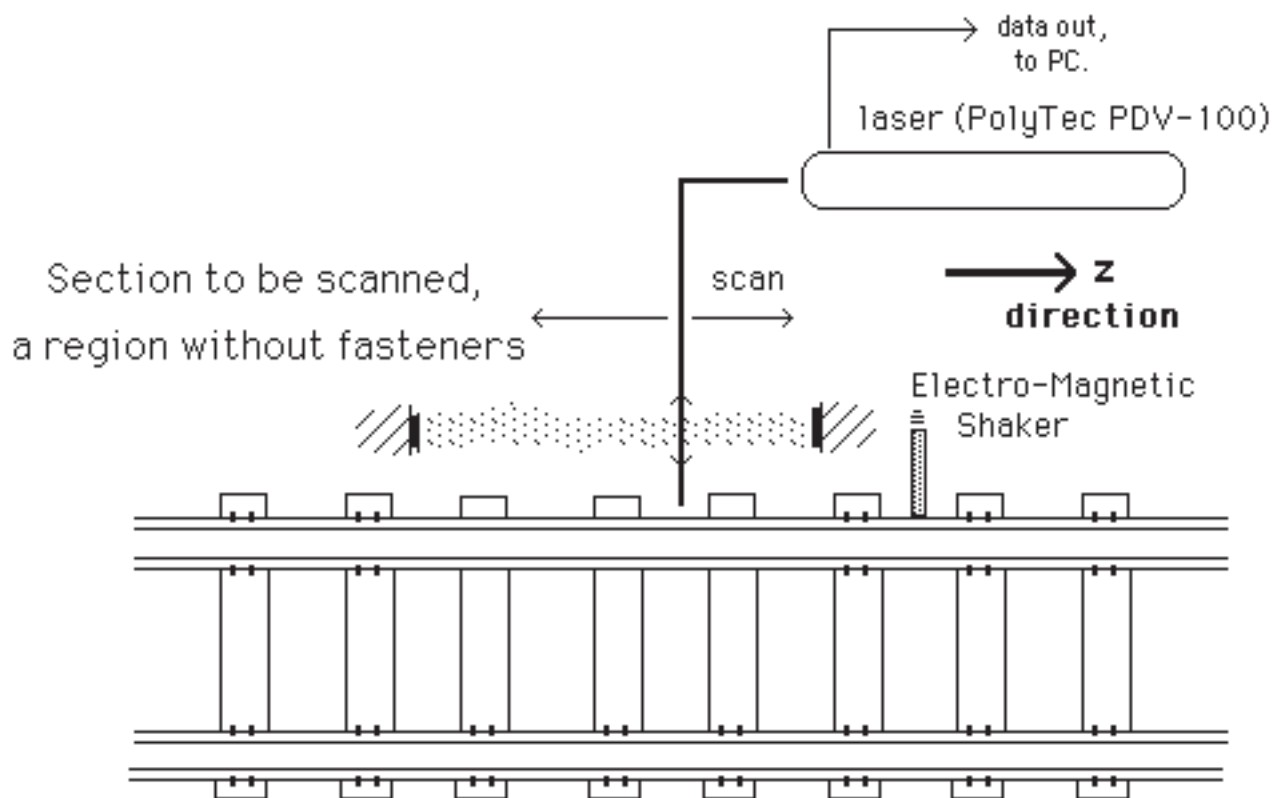

**Figure 2**

*Schematic of laser vibrometer*



## **HSR-37: Electroslag Field Welding of Rail**

Electroslag Systems  
Portland, Oregon

### **IDEA Concept and Product**

This project is investigating the use of electroslag welding (ESW) techniques as an alternative to thermite or flashbutt welding for field welding of rails. Heat is generated by resistance as the welding current passes through a molten flux pool that floats on top of the liquid metal. Containment components, e.g., cooling shoes on the sides of the rails, are used to contain the welds, and a consumable electrode directs weld wire to the weld.

Electroslag welding has the potential to produce a stronger, better quality weld than the current thermite field welding process.

The investigative approach included developing an efficient electroslag welding process. Elements of that

process include consumable electrode configuration, starting sump design, weld chemistry, welding parameters (volts, amps, travel speed, wire feed, etc.), flux, and cooling requirements. Alternative weld wires, fluxes, and cooling shoe materials will be selected, as well as various configurations of consumable guide tubes, cooling shoes, and fixturing. The most promising was then used to weld test rail segments, and these welds evaluated using ultrasonic inspection and destructive testing based on American Railway Engineering and Maintenance of Way Association specifications. Metallographic specimens of the weld were prepared to examine weld and heat-affected zone dimensions and microstructures, and weld specimens were tested for hardness.

### **Project Progress**

Tasks completed include the selection and evaluation of alternative weld wires, fluxes, and cooling shoe materials, and various configurations of consumable guide tubes, cooling shoes and fixtures. The most promising

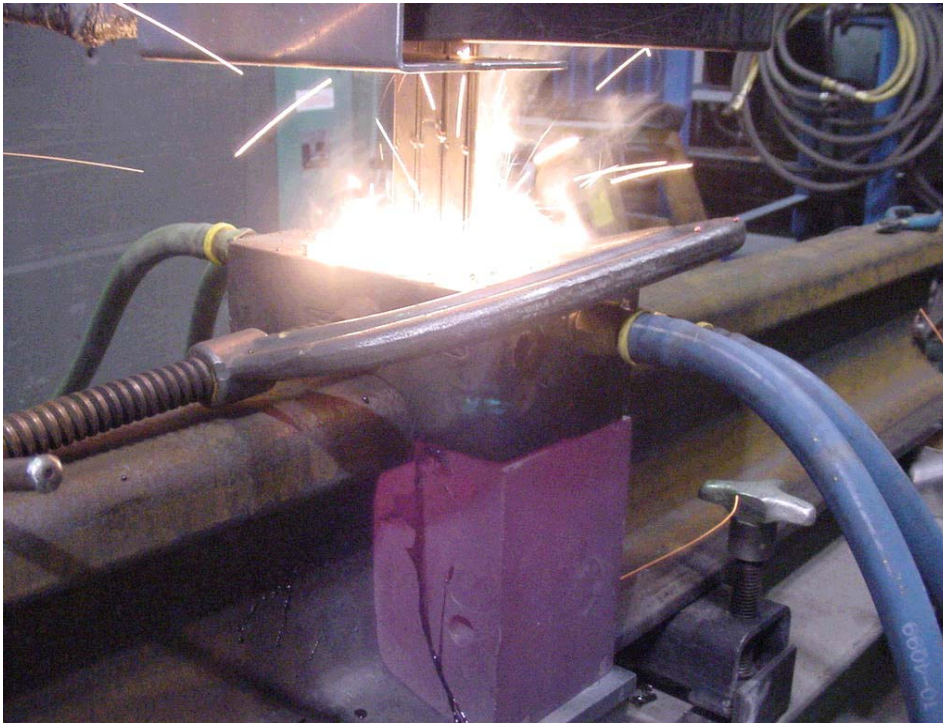

**Figure 1**

*Electroslag weld in progress during lab test*

were then used to weld test rail segments and evaluate them using ultrasonic inspection and destructive testing based on AREMA specifications. This led to the design and casting of a new version of weld cooling shoes. Tests were also conducted to determine the effects of different weld current on the heat-affected zone of the welds. Subsequent tasks included development of further improvements to the technique, including the development of optimum values for weld duration, voltage, amperage, chemical composition, wire speed, weld geometry, and preheating. A comparative analysis with thermite welding was conducted, including track time requirements, weld quality, training requirements, and costs.

The work was completed in October 2003. Some, but not all, of the objectives were achieved. The hardness and microstructure objectives were met. The rupture

modulus objective was 125,000 psi, but the test specimens achieved only 119,300 psi. The maximum deflection objective was at least 0.75 inch, but deflections of only 0.35 inch were achieved. The contractor, Electroslag Systems, Technology and Development, is confident these two objectives can also be met or exceeded, and plan to pursue these improvements to develop a commercially viable product  
Principal Investigator: Dan Danks

Technical Advisor:

Bob Galloway, BNSF RR

IDEA Contract: \$94,160

Cost Sharing: \$10,000

Project Total: \$104,160

Start: September 2002

Complete: October 2003

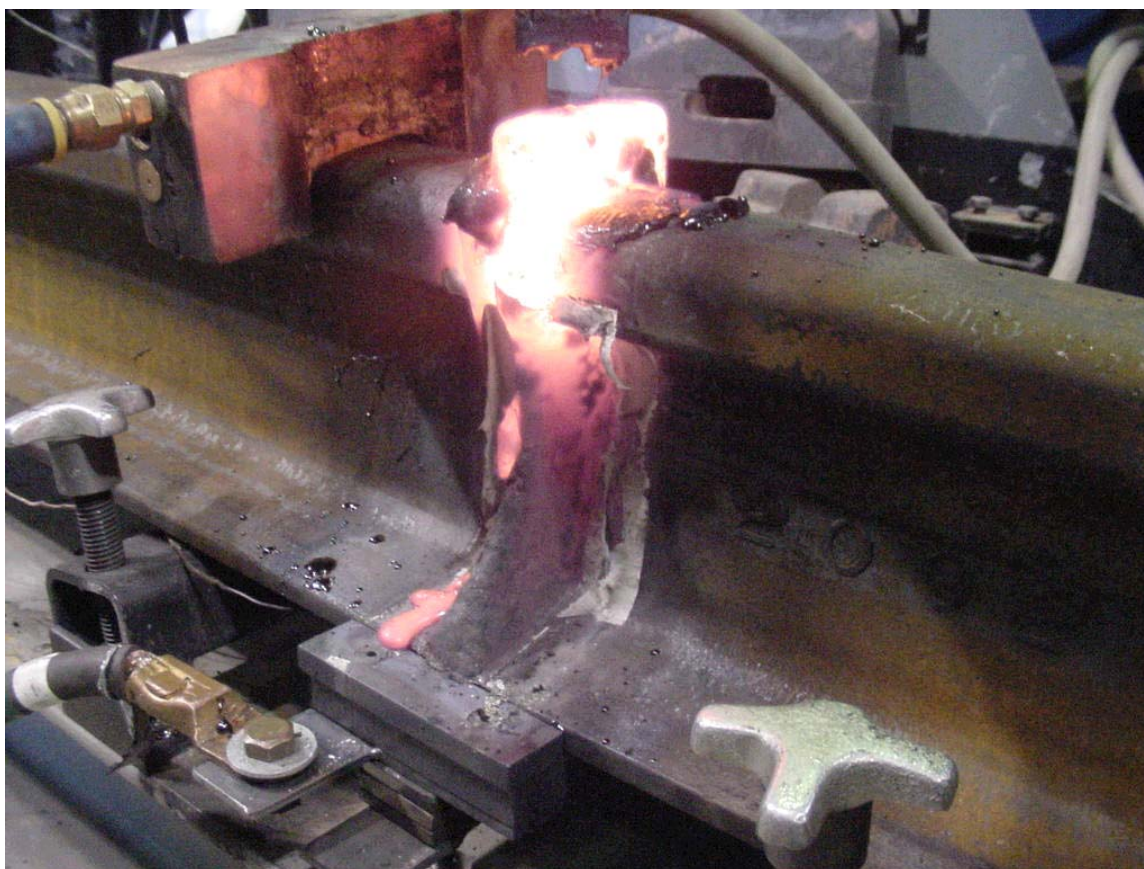

**Figure 2**

*Electroslag weld after cooling shoes have been removed and before removal of excess weld metal*



## **HSR-38: Feasibility of Locomotive-Mounted Broken Rail Detection**

Analogic Engineering, Inc.  
Guernsey, Wyoming

### **IDEA Concept and Product**

This is a project to extend the capability of existing Multiconductor Transmission Line (MTL) models of railroad track to simulate and explore the effects of broken rails and track occupation. The objective is a preliminary assessment of the feasibility of transmitting coded bursts of radio frequency (RF) energy into the rails ahead of locomotives and analyzing the reflected pulses to detect rail breaks. The models will be used to determine how RF pulses will propagate through the rails and how they will interact with rail breaks as well as with normal discontinuities such as turnouts. Specifically, they will be used to test the feasibility of coupling coded, differential RF pulses into the rails (ahead of the locomotive's lead axle) and analyzing reflected pulses to detect and calculate the distance to the rail break or track occupancy. The existing models would be extended to simulate combinations of track conditions, rail break types, train location, and movement patterns. The investigative approach is basically to extend the capabilities of an existing model, and use it to perform a series of simulations. These would be designed to assess how well the proposed technology would work for accurately detecting broken rail and the location of other trains ahead of the locomotive on which the system would be installed. The findings of this project would be used to determine whether further development of this concept, including prototype development and testing, would be warranted.

### **Project Progress**

A literature review and analysis, initial model development, and preliminary feasibility testing were performed. Subsequent tasks included investigation of alternative techniques for coupling the RF pulses into the rail, the effects of insulated joints, turnouts, the effect of the local train axle shunts immediately behind the measurement point, and possible radiation hazards to personnel in the locomotive and on the ground. The investigation revealed that three or more combinations of pulse frequency and duration would be required to cover the range from just ahead of the locomotive out to a maximum distance of 1 to 2 miles. Detection as far as 1 to 2 miles would require RF pulses between 60 KHz and 120 KHz with peak power in the order of 10 KW. Detection beyond turnouts would require electrical circuit switching operating in parallel with mechanical track switching. Investigation of the potential for radiation hazards using a model and current radiation exposure limits revealed that even at these power levels, frequencies in the 60 KHz to 120 KHz range pose no risk to humans. Further development of this concept will require the design and development of a prototype system. The prototype system would then be subjected to laboratory and field trials to determine how performance would be affected by such factors as insulated and bolted rail joints, rail welds, various kinds of ballast contamination, and turnouts.

Principal Investigator: Steven Turner

#### Project Panel:

Jeff Gordon, DOT Volpe Center  
Robert Kubichek, U. of Wyoming  
Bob McCown, FRA  
Don Plotkin, FRA  
Rich Reiff, TTCI

IDEA Contract: \$41,264

Cost Sharing: \$11,094

Project Total: \$52,538

Start: October 2002

Complete: April 2003

## HSR-40: Rubber-Modified Asphalt Concrete for High-Speed Railway Roadbeds

Case Western Reserve University  
Cleveland, Ohio

### IDEA Concept and Product

This project is investigating the potential of a layer of rubber-modified asphalt concrete (RMAC) under track ballast to improve the durability and reduce the deformation, vibration, and noise of track structures for high-speed rail (See Figure 1). Preliminary studies indicate that the damping ratio of rubber-modified asphalt concrete is 6–11% compared with 2–3% for compacted soil and 3–4% for conventional asphalt concrete. In addition, it has stiffness two to three orders of magnitude higher than typical compacted soil. Based on these findings, RMAC has the potential to significantly reduce the pressure on soil subgrade and reduce the vibration from passing trains to the surrounding environment. The IDEA product will include specifications, performance assessments, and cost estimates for use by the high-speed railroad industry to determine whether and how such installations should be made in the track structure.

### Project Progress

Numerical simulations were performed to assess the effectiveness of RMAC and conventional asphalt concrete to reduce vibrations generated by high-speed

trains. RMAC reduced the vibrations by about 30% and conventional asphalt concrete by about 10%. These results were used to design a series of laboratory tests to measure the stiffness and damping ratio of RMAC under loading conditions associated with typical axle loads, and the durability of RMAC under a full range of environmental and railroad operating conditions. These laboratory tests are underway. Computer simulations were also performed to investigate the influence of the depth and thickness of the RMAC layer on performance and, for comparison, on the same system without the RMAC layer.

Principal Investigator: David Zeng

Project Panel:

Bob Grace, GDE, Inc.  
Dingqing Li, AAR/TTCI  
Jerry Rose, University of Kentucky  
Tom Schmidt, CSX Transportation

IDEA Contract: \$100,000

Cost Sharing: \$72,039

Project Total: \$172,039

Start: January 2003

Complete: December 2004

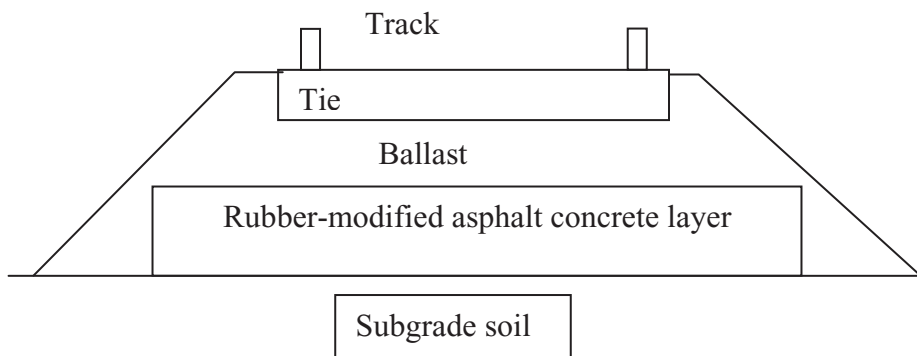

**Figure 1**

*Schematic for location of RMAC layer*

## HSR-42: Acoustic Broken Rail Detection System

San Francisco Bay Area Rapid Transit District  
Oakland, California

### IDEA Concept and Product

This is a project to develop a system of acoustic transducers to detect broken rail. Nodes of these acoustic transducers would be installed on the rail at spacings approaching one mile. Each transducer would excite the rail at specific frequencies as well as sense the presence of acoustic energy in the rail. These acoustic nodes would be networked such that each node would relay the data it receives to the next node up the rail to deliver the information to a central control location. Each node could detect reflections from rail discontinuities (breaks) and time the reflections to determine the distance from the node. This information would be transmitted through the rail via the network of acoustic transducer nodes to a control location such as a dispatch center (Figure 1).

The San Francisco Bay Area Rapid Transit District (BART) has already spent \$600,000 on a proof-of-concept study of this approach under a Cooperative Re-

search and Development Agreement (CRADA) between BART and Sandia National Laboratories. The study is part of the development of an Advanced Automatic Train Control (AATC) system at BART under a \$20 million DARPA grant administered by the Federal Transit Agency. Research under the CRADA has discovered a mode of vibration and specific frequencies of excitation that enable acoustic energy to travel distances of more than 2 miles in (continuous welded) rail. The scope of the project included recording acoustic signal profiles from various rail discontinuities, including complete and partial breaks, and cracks and flaws, and the development and testing of an algorithm for detecting time of arrival of reflected signals. A prototype system would then be developed and field-tested on BART's 2.5-mile test track in Hayward, California.

### Project Progress

Initial tasks included incrementally cutting rail test sections vertically and at angles to simulate partial rail breaks. The acoustic signal profiles of reflections from these cut rail sections, and from complete rail breaks, were recorded. A time-of-arrival algorithm was developed and verified using the recorded test data. On BART'S mainline, signals were recorded for different frequencies and different trains using a broadband transponder. Analysis of this data was used to determine

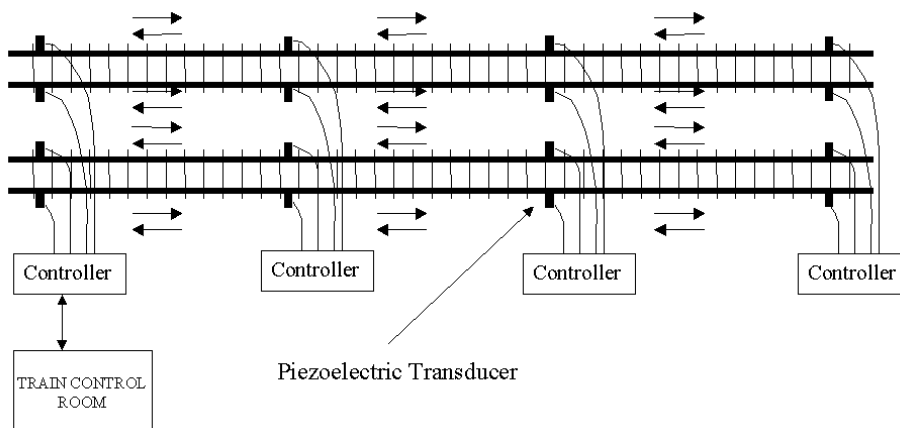

**Figure 1**

*Diagram of the proposed acoustic broken rail detection system*

optimum transponder frequency and bandwidth. Other tasks included development of time-of-arrival software, fabrication of a prototype system, and field testing and evaluation. The BART project team encountered problems in the development of the prototype. These included significant changes in the optimal transmission frequency with changes in rail temperature; side-mounting transducers on the rail web did not produce significant longitudinal waves, severely limiting the range; inability of the prototype to detect various types of rail defects and breaks; inability to develop robust transmission algorithms; and significant reductions in range during rain. As a result, further development and testing were discontinued. A final report was prepared that documents the tasks performed, problems encountered, and recommendations for future research should this concept be further pursued.

Principal Investigator: John Evans

Project Panel:

TBD

IDEA Contract: \$100,000

Cost Sharing: \$400,000

Project Total: \$500,000

Start: July 2003

Complete: February 2004 (est.)



## **HSR-46: Magnetorheological Damping for Spring Rail Frog Switches**

Texas A&M Research Foundation  
College Station, Texas

### **IDEA Concept and Product**

This contract is to investigate the application of a magnetorheological (MR) damper in place of a conventional hydraulic shock retarder in spring rail frog switches. The spring rail frog switch is used in main-line track where the preponderance of traffic is through trains with only occasional diverging route usage for passing sidings or infrequently used industry tracks. The spring rail frog switch is useful for this service because no power machinery is required and manual throwing of the switch machine is required only for train entry. The spring rail frog switch closes against the frog after the trailing axle of each car truck using the force of the springs in the system. However, the cycling action of the spring rail frog rails contributes to rapid wear and loosening of the entire system. Currently, hydraulic retarders are used to minimize cycling of the spring rail frog rail against the point-of-frog as trains exit spring switches. These hydraulic retarders (shock absorbers) are used to keep the spring rail away from the frog for extended periods to allow multiple car trucks to pass. Railroads report that the current retarder system does not have a reliable or long life due, presumably, to high internal forces in the retarder during train passage.

An MR damper resembles an ordinary dashpot or linear viscous damper. It uses a special MR fluid and has one or more electromagnetic coils wrapped around the piston head. The MR fluid contains small particles that can be magnetically polarized. As a result, when current is supplied to the coils, the MR fluid becomes semi-solid. Damping is proportional to the amount of current applied. The proposed system would include a control algorithm designed to prevent or minimize cycling of the spring rail frog rail until all cars in the train have passed through. An accelerometer or other sensor attached to the piston rod would detect accelera-

tion and velocity of the rod when activated by a passing train. The sensor signal would be used by the algorithm to activate the MR damper and determine the amount of damping required. A 12-volt battery kept charged by solar cells would provide power to the system.

### **Project Progress**

The project tasks include design and fabrication of an MR damper prototype, development of a control algorithm, and field tests of the prototype installed in a spring rail frog switch. Spring rail frog switch operating data have been collected in the field for simulations of MR damper designs. A prototype MR damper has been designed and fabricated, and lab tested using a representative range of displacements, velocities, forces, and applied currents. Tasks under way include development of a control algorithm. Upon completion of the lab tests and the algorithm, preliminary testing will be conducted on a railroad. The prototype will then be installed in a spring rail frog switch at the Transportation Technology Center in Pueblo, Colorado, to evaluate its performance and make any necessary improvements. It will then be installed on a railroad and monitored to provide additional data on performance, reliability, and survivability. A cost-benefit analysis will be performed to compare the estimated life-cycle costs of an MR damper system with conventional hydraulic dampers.

Principal Investigator: Les Olson

Project Panel:

Dave Davis, TTCI  
Hank Lees, BNSF  
Bob McCown, FRA

IDEA Contract: \$100,000

Cost Sharing: \$57,000

Project Total: \$157,000

Start: February 2004

Complete: August 2005

**Rolling Stock**





## HSR-20/34: Metal Foams for Improved Crash Energy Absorption in Passenger Equipment

Fraunhofer Center  
Delaware

### IDEA Concept and Product

Lightweight cellular materials known as metal foams are a newly emerging class of engineering materials that are currently being evaluated for a broad range of transportation applications. Fraunhofer has developed a powder metallurgy process for producing ultra-lightweight metal foams from aluminum, steel, and other metals and alloys. Because of their very low mass density, controlled porosity, and closed-cell structure, aluminum foams especially are finding engineering uses as lightweight stiffeners in automobiles; energy absorption in crash management, ballistic protection and mine blast mitigation; vibration damping; and sound/thermal insulation. Aluminum foam structures can be designed to provide multifunctional properties, thus providing a high value/cost ratio.

The objective of these two projects was to identify and evaluate the potential benefit of aluminum metal foams in structural members of locomotives and passenger cars

for improvement of crush energy absorption. An additional goal was to identify other potential advantages of using aluminum foams in locomotive and passenger car structures. Potential applications of aluminum foam were identified and assessed, such as reducing equipment weight, strengthening collision posts, enhancing fire resistance, and increasing overall passenger safety and comfort.

### Project Progress

The axial crushing tests on both hollow aluminum tubes and tubes filled with low-density aluminum foam revealed that the foam filling increases the stability of the profile and prevents instantaneous buckling. The aluminum foam inserts increased the energy absorption of both aluminum and 304 stainless steel tubes by 30-40% (Figure 1). Three-point bending specimens of empty and aluminum foam-filled tubes of aluminum and 304 stainless steel were also fabricated and tested to evaluate the effectiveness of aluminum foams in increasing the bending strength and side-impact load bearing capability. The measured peak bending loads of foam-filled tubes were up to 50% higher than the summation of the aluminum foam and empty tube specimens tested individually. Results from these tests indicated that aluminum foam-filled tubes not only increased the overall peak load-bearing capability of tubular structures,



**Figure 1**

*Deformed aluminum foam-filled stainless steel tube after axial compression*



but also prevented the structure from experiencing rapid deformation under load. This combination of features makes foam-filled profiles good candidates for both light-weight stiffening and energy absorbing elements.

Joining methods for attaching aluminum foams to other materials of construction were also investigated. Experimental results demonstrated successful joining of aluminum foams using conventional tungsten inert gas (TIG) welding, laser welding, soldering, low-temperature active brazing, and adhesive bonding.

Project results identified several potential applications of aluminum foams in high-speed rail equipment. These include improved crash energy absorption, strengthening collision posts and side impact beams, and reducing equipment weight through use of aluminum foam sandwich panels. These foam sandwich panels have very high stiffness-to-weight ratio and superior fire resistance, vibration damping, and sound insulation compared with conventional aluminum plates for floor panels, walls, and bulkheads.

Based on the findings of this concept exploration project, a follow-on product application contract was awarded to continue this work. Tasks included the redesign, fabrication, and testing of conventional passenger car components using aluminum foam-filled structural elements. Finite element model calculations were performed to determine the stiffness of various aluminum foam panel designs. These values have been compared

with those for steel panels, and the estimated weight savings by substituting aluminum foam panels for steel panels are substantial. These foam panels provide the additional benefits of vibration and sound dampening, and increased thermal insulation. Candidate tubular components for aluminum foam inserts were also designed. These were fabricated and subjected to test and evaluation. An energy-absorbing sliding rail for installation on passenger car seats was subjected to full-scale testing. This application uses an aluminum foam-filled piston/cylinder design that can be placed at the seat mounting points. Instrumented test dummies mounted on a test sled were used to simulate train collisions (Figure 2). The crushing of the foam in the cylinders absorbed sufficient crash energy to significantly reduce the potential for passenger injury.

Principal Investigator: Ken Kremer

Project Panel:

George Binns, Amtrak

Steve Sill, FRA

Dave Tyrell, DOT Volpe Center

IDEA Contract: \$100,000 Initial / \$200,000 Follow-on

Cost Sharing: \$80,000 / \$150,000

Project Total: \$180,000 / \$350,000

Start: October 1999 / March 2002

Complete: May 2001 / March 2004



**Figure 2**

*Test sled with instrumented test dummies*

## HSR-29: Continuous Locomotive Emissions Analyzer

Scentezar Corporation  
Fredericksburg, VA

### IDEA Concept and Product

In 1998 EPA promulgated new emissions regulations that phase in more restrictive  $\text{NO}_x$  standards for locomotives. This, combined with rising diesel fuel costs, confronts railroads with challenging tradeoffs between fuel economy and compliance with emission standards. Greater locomotive fuel economy can be achieved with leaner fuel mixtures, but leaner mixtures increase  $\text{NO}_x$  emissions. Currently, railroads do not have a convenient instrument for measuring  $\text{NO}_x$  emissions, so optimizing fuel use while meeting EPA standards has to be based on guess work and indirect measurements such as cylinder temperature.

This project investigated a locomotive emissions analyzer that could be mounted on locomotives and continuously monitor their exhaust emissions. Ion Mobility Spectrometry (IMS) was selected for the sensor technology because of its rapid response time, low cost, and small size. IMS sensors consist of a reaction tube and a drift tube, separated by a shutter grid (Figure 1). Exhaust gas entering the reaction tube is ionized, and the ions are gated into the drift tube through the shutter grid. The ions are drawn down the drift tube toward a Faraday cup where they impact a metal plate and transfer their charge, creating an electric current. This current is amplified and digitized, and the analysis of this signal can be translated into concentrations of  $\text{NO}_x$ . The analyzer output would be used to continuously control engine settings such as injector timing to achieve the optimum balance between engine efficiency and exhaust emissions.

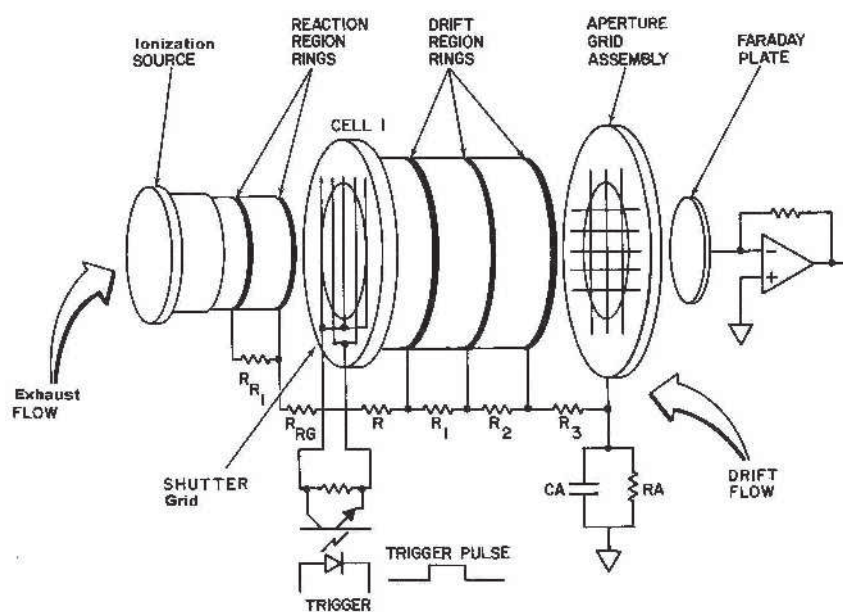

**Figure 1**

*Schematic of Ion Mobility Spectrometry Sensor*



## Project Progress

A prototype analyzer was developed and laboratory tested using known concentrations of NO and NO<sub>2</sub>. The analyzer was then tested on an 8-cylinder diesel engine (Figure 2). The stationary engine was equipped with a chemiluminescence analyzer to enable comparisons of the prototype sensor data with the standard EPA method. Preliminary analysis of the test data revealed calibration and data recording problems. Efforts to determine whether more sophisticated statistical analysis techniques can be used to provide a more definitive assessment of the prototype system proved unsuccessful. A final report was prepared that documents the work performed, findings, an explanation of the problems with the diesel engine testing of the analyzer, and recommendations for any future investigation of the technology.

Principal Investigator: Joe Roehl

Project Panel:

Dick Cataldi, Virginia Railway Express

Chuck Horton, EMD

Kevin Kirby, HRL

Mark Stehly, BNSF RR

IDEA Contract: \$99,917

Cost Sharing: \$20,151

Project Total: \$120,068

Start: December 2000

Complete: January 2002



**Figure 2**

*Diesel engine test stand*

## HSR-32: High-Strength, Lightweight Car Bodies for High-Speed Rail Vehicles

Surface Treatment Technologies, Inc.  
Baltimore, Maryland

### IDEA Concept and Product

This project examined a novel approach for building safer high-performance, high-speed passenger car shells. The objective was to evaluate the potential of using scandium-containing aluminum alloys in combination with advanced joining and fabrication approaches to increase performance, reduce operating costs, and improve the safety of high-speed passenger rail vehicles. The approach combined three key elements 1) light-weight, high-strength, weldable aluminum scandium alloys; 2)

advanced joining techniques (friction stir welding); and 3) advanced processing to fabricate net-shaped panels. A major task was to select the optimal scandium-containing aluminum alloy composition for high-speed passenger rail applications. At present, aluminum scandium alloys are seeing widespread use in “high tech” sporting good products such as ball bats, bicycles, golf clubs, and lacrosse poles. Although this family of alloys is now available commercially, it has not been optimized or qualified for use in rail passenger vehicles.

Scandium provides the highest increment of strengthening per atomic percent of any alloying element when added to aluminum. Small amounts of scandium are very effective at improving mechanical properties and refining the microstructure of wrought aluminum alloys. In addition, scandium additions have been shown to improve weldability of aluminum alloys by reducing

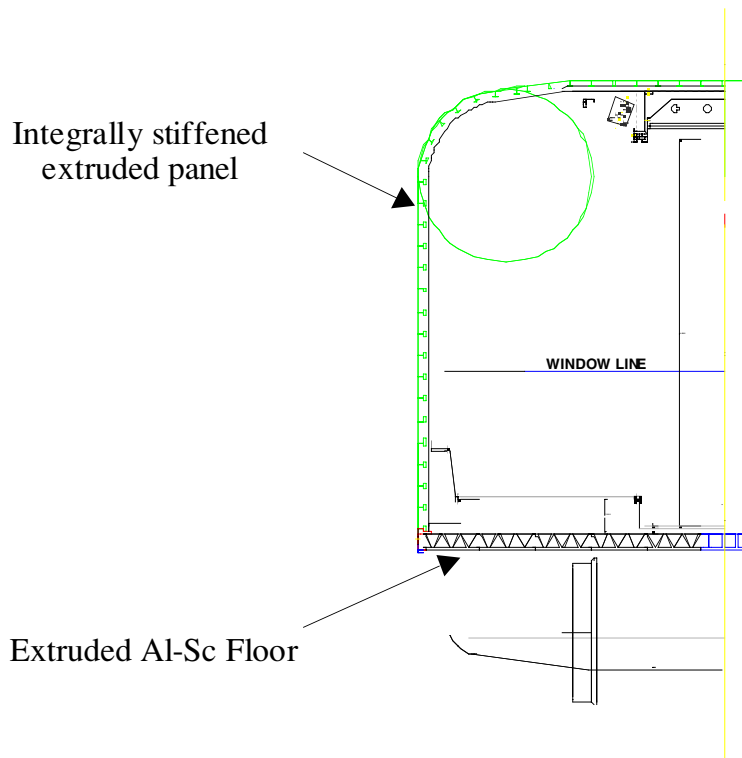

**Figure 1**

*Preliminary design for car body shell using Surface Treatment Technology's net shaped extrusion concept*



hot cracking in the weld region. In the current study, researchers performed a trade-off study to determine if scandium additions would improve the performance of conventional Al-Mg 5XXX and Al-Mg-Si 6XXX alloys and if a scandium containing Al-Zn-Mg-Cu 7XXX series alloy could be used to fabricate car body shells.

### Project Progress

Ease of fabrication, mechanical properties, weldability, and corrosion resistance were evaluated for candidate and conventional alloys. The ability to fabricate complex extrusions was evaluated for the candidate and conventional alloys using a porthole die. All alloys were successfully extruded using common commercial practices. Metallographic evaluation of the extrusions showed that, as expected, the Sc addition refined the

grain size in an Al-Mg 5xSc alloy and an Al-Zn-Mg-Cu 7xSc. The key result was the good corrosion resistance and high base metal and weldment strengths observed for the selected aluminum-scandium alloy (Al-Zn-Mg-Cu 7xSc). These properties in combination with the ease of fabrication lead to its selection as the optimal composition for high-speed rail applications.

Advanced design and fabrication techniques were also evaluated. Car body shells for passenger cars are fabricated using various approaches, including mechanically fastened sheet and stringers. Recent efforts in Japan and Europe have focused on building shells from welded aluminum extrusions. The use of large integrally stiffened extruded panels was evaluated. In this approach the side walls and top of the car body are fabricated

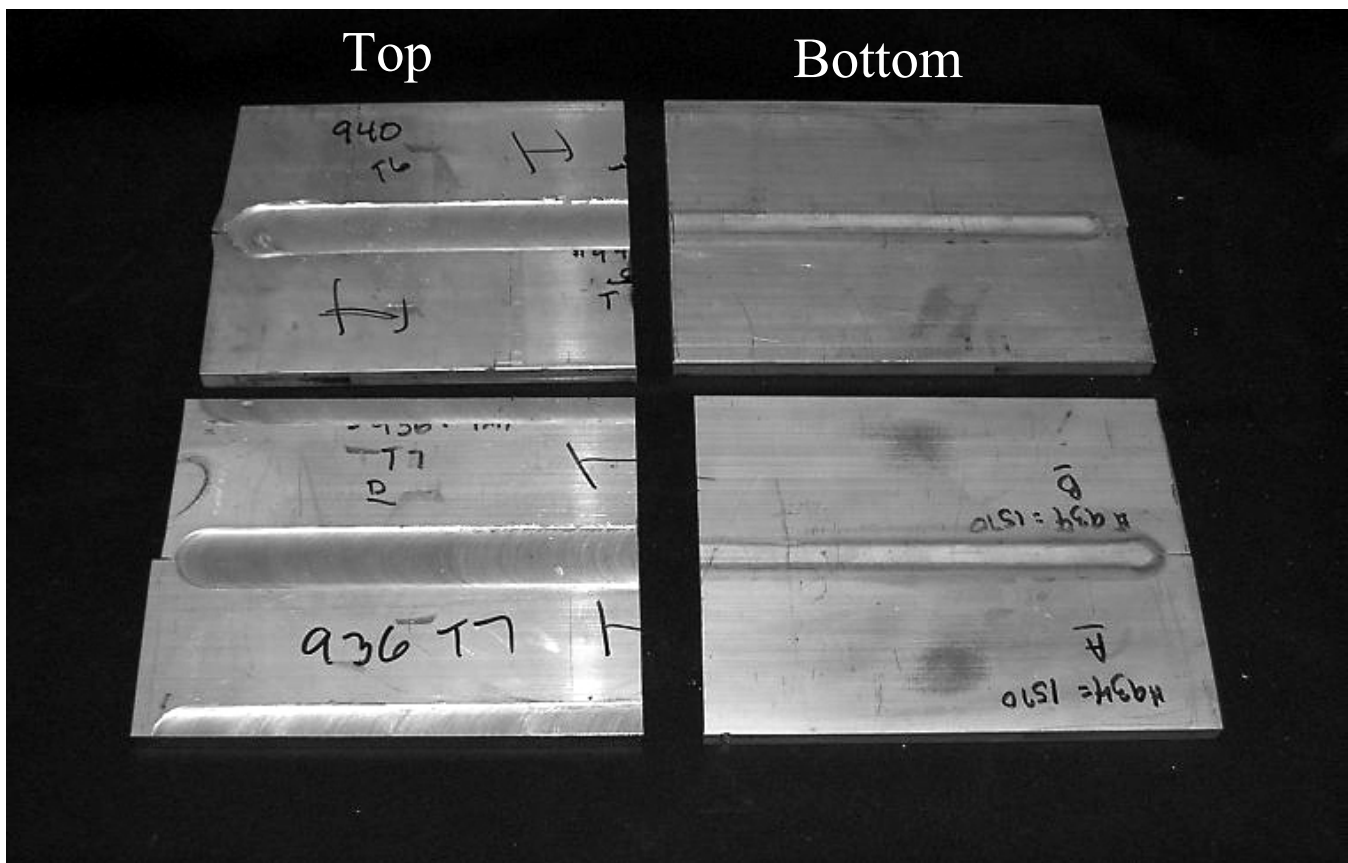

**Figure 2**

*Friction stir welded high-strength advanced aluminum scandium alloys. This welding technique appears to be well-suited for these new, lightweight alloys.*

from large, net-shaped scandium-containing aluminum alloy extruded panels. Integrally stiffened extruded panels as large as 8 feet wide by 35 feet long have been fabricated for aerospace applications. The safety of the passenger car shell is greatly improved by removing longitudinal welds currently used to join aluminum extrusions, thereby increasing resistance to side impact. A finite element analysis showed that car bodies fabricated using integrally stiffened extruded panels are more resistant to side impact. The project team for this project collaborated with the Fraunhofer project team investigating metal foam technology (HSR-20/34). Both teams developed ways to incorporate their respective technologies and techniques into new train set designs.

Principal Investigator: Tim Langan

Project Panel:

George Binns, Amtrak

Steve Sill, FRA

Dave Tyrell, DOT Volpe Center

IDEA Contract: \$96,703

Cost Sharing: \$0

Project Total: \$96,703

Start: June 2001

Complete: January 2004

## HSR-39: Hand-Held Wheel Crack Detection Device

International Electronic Machines  
Albany, NY

### IDEA Concept and Product

This project developed and demonstrated a portable, hand-held device to probe railway wheels for cracks. The concept uses electromagnetic acoustic transducer (EMAT) technology and digital signal processing techniques. The EMAT sensor consists of two non-contacting electromagnetic coils: a transmitting coil to propagate an ultrasonic wave into the wheel, and a receiving coil to receive an ultrasonic echo signal from the wheel. These echo signals will be processed and interpreted to detect defects such as cracks, voids, and splits in the flange, plate, or tread of the wheel.

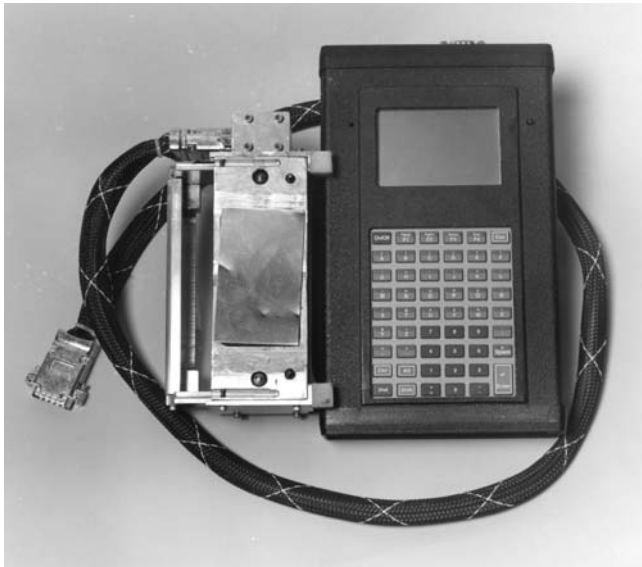

**Figure 1**

*Prototype wheel crack detector that can inspect the wheel tread surface. Further enhancements will include the capability to detect rim defects, cracks, voids, or splits in the wheel flange and plate.*

Potential advantages of this technology are that it can see beneath surface defects, rust, grease, and surface flaws. It will be designed to inspect both mounted and removed wheels. Current wheel crack detectors are too large for use in the field. The portability of this device would enable field use, e.g., for yard inspections. The software and display would be designed to characterize defects for easy decision making rather than just displaying a waveform, which is often difficult to interpret. The approach included the design and development of hardware and software, and the prototype was tested using wheels with known defects.

### Project Progress

Tasks included: development of functional and performance requirements based on frequency of types and locations of defects, portable pulser and power supply designs, defect sensor design, and prototype system design and fabrication. Laboratory and field testing of the prototype were conducted. These tests assessed the system's ability to positively identify defects of different types, sizes, orientations, and depth beneath the surface. The tests were conducted using wheels with known defects. Based on the preliminary test results, improvements were made to the prototype. The initial version is designed to detect tread and flange defects. Future versions will be improved to include the capability to detect rim defects.

Principal Investigator: Zack Mian

Technical Advisor: Greg Garcia, AAR/TTCI

IDEA Contract: \$99,596

Cost Sharing: \$200,000

Project Total: \$299,596

Start: August 2002

Complete: July 2004

## HSR-44: Permanent Magnet DC Traction Motor

SPAD Engineering Company  
Vienna, Virginia

### IDEA Concept and Product

This is a project to design, fabricate, and test a brushless permanent magnet direct current (PMDC) locomotive traction motor. The concept has the potential for a motor that will have higher torque and power capacity than either conventional DC or AC traction motors. The PMDC traction motor will have an electronic commutator arrangement that reconfigures the stator windings from series to parallel combinations to reduce the rate at which back-emf increases with speed. This reduces the voltage increase normally required to overcome increased

back-emf associated with increasing speed, and thus improves the torque-speed performance. The contractor estimates that this motor would be  $\frac{1}{4}$  the size and weight of present motors of the same horsepower rating. Initial tasks will be to conduct analyses to assess the feasibility of the concept. If the analyses indicate the concept is viable, subsequent tasks will be the design and fabrication of a prototype configured to be installed in the casing of a GP-38 traction motor. This prototype would be tested in a traction motor test stand to determine its speed-torque characteristics. If this project proves successful, a next step could be to fabricate four prototypes and install them under a locomotive, such as a GP-38, for a full field test.

### Project Progress

A preliminary design of the prototype motor has been developed. The design was analyzed, including finite

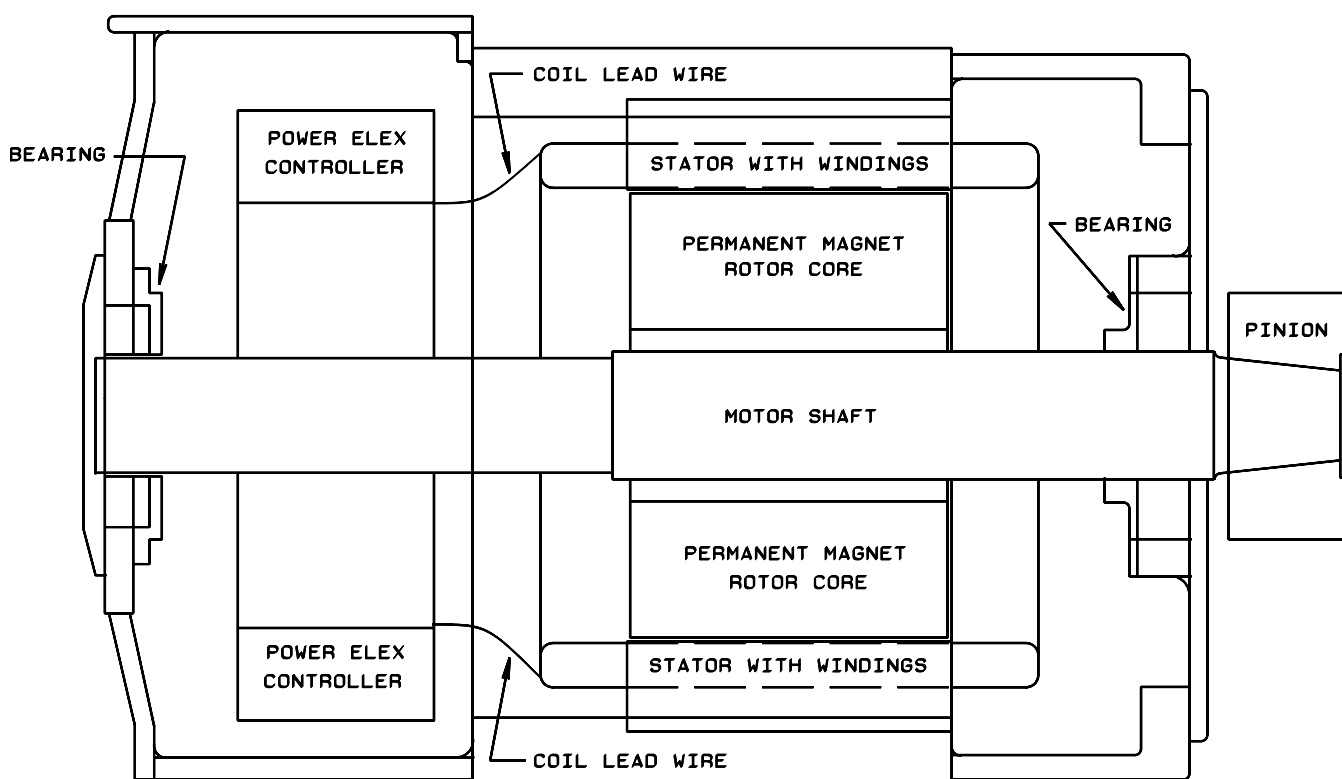

**Figure 1**

*Schematic of the permanent magnet DC traction motor designed to fit in the casing of a current locomotive traction motor.*



element analysis verification and thermal analysis. A small proof motor was developed and tested, and the proof motor test data analyzed, along with test data for a full-scale motor developed by the contractor for the U.S. Navy that employs the same general concepts as the locomotive motor. Remaining tasks include development of the detail design and specifications, and the fabrication of the prototype motor and motor controller. This motor will be tested on a test stand using a test protocol based on railroad industry traction motor performance specifications and standard test procedures.

Principal Investigator: Nick Rivera

Project Panel:

James Kirtley, MIT  
Bob McCown, FRA

IDEA Contract: \$240,159

Cost Sharing: \$30,000

Project Total: \$270,159

Start: June 2003

Complete: August 2005



**Figure 2**

*Full-scale 1,000 horsepower permanent magnet DC motor with integrated controller, designed for propulsion of Navy ships.*

## HSR-45: Crash Energy Absorption System for Rail Passenger Seats

Paragrate  
Bellevue, Washington

### IDEA Concept and Product

This is a concept exploration project to assess the potential of Solid Ejection Material (SEM) crash energy absorption technology for high-speed rail applications. A basic SEM model consists of an impact piston inside a shock housing, and the end of the piston inside the housing is in contact with a ductile or yieldable solid (polymer). The housing contains an ejection groove or ejection ports. If the piston is impacted, such as in a collision, the other end of the piston forces the ductile or yieldable solid through the ejection groove or ports, thereby absorbing much of the crash energy. The specific application of this proposed technology is the development and testing of an SEM shock track for mounting seats in rail passenger cars (Figure 1). In the event of, for example, a head-end or rear-end collision, the SEM shock track mounting would provide controlled

acceleration and deceleration of the seat assembly. Although rail passengers do not wear seat restraints, the controlled acceleration-deceleration would provide some protection to passengers thrown into the back of the seat ahead in the event of a head-end collision. In the event of a rear-end collision, the shock track would absorb much of the energy forcing the seats to the rear. The shock track would also reduce the likelihood of the breakaway of seat assemblies.

The initial task of the investigative approach is to determine the performance requirements for the system, including desired restraint loads and breakaway requirements. These would direct the design of the prototype system with respect to such things as ejection groove dimensions, selection of solid ejection materials, and design of the shock track and its connections with the seat assembly and car body. Preliminary performance assessments will be conducted using computer models. A full-scale prototype would then be fabricated and tested. The test data would then be analyzed to determine whether the prototype met the performance requirements.

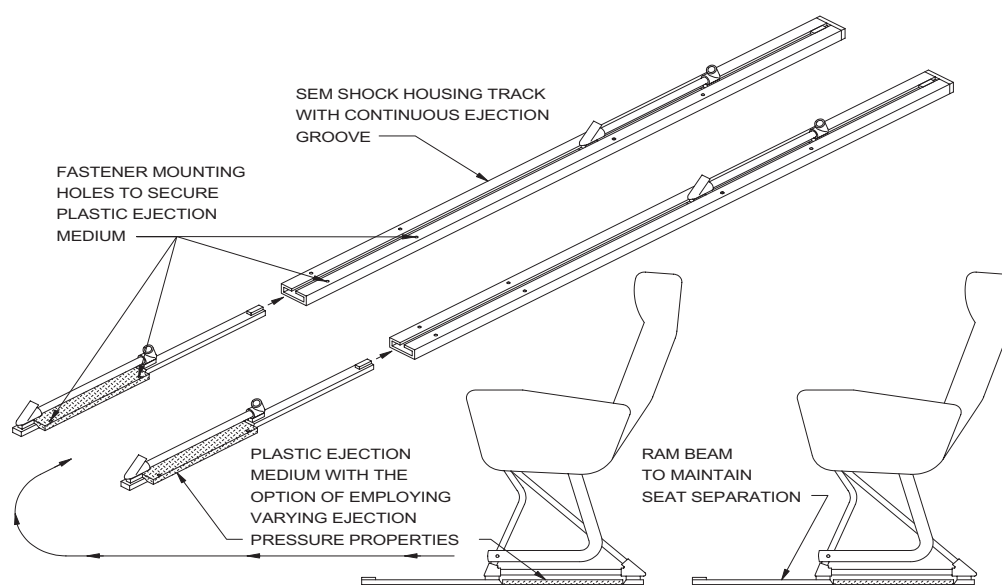

THE SEM SEAT MOUNTING TRACK WOULD BE DESIGNED TO SUPPLY BOTH FORWARD AND REVERSE LOAD RESTRAINTS, FOR FORWARD TRAVEL COLLISIONS AND /OR REAR-END COLLISION EVENTS

Figure 1



## Project Progress

Progress to date includes the identification of relevant railcar seat crashworthiness specifications (FRA, APTA, overseas), the preliminary design of the seat mounting, development of a preliminary test plan, including the design of a test sled for crash testing of the prototype seat mounting (Figure 2) and SEM crash energy absorption system. The design of the seat mounting system has been completed and installed in the test sled. Crash testing using instrumented test dummies will be conducted at the Texas Transportation Institute.

Principal Investigator: Stephen Knotts

Project Panel:

Kent Barnes, Raytheon  
Dave Tyrell, DOT Volpe Center  
Dean Alberson, Texas Transportation Institute

IDEA Contract: \$84,620

Cost Sharing: \$0

Project Total: \$84,620

Start: August 2003

Complete: December 2004



**Figure 2**

*Bogie vehicle for impact tests. Instrumented test dummies will be mounted in seats.*

## **HSR-47: Application of LAHUT Technology for Wayside Detection of Cracked Wheels**

Transportation Technology Center, Inc.  
Pueblo, Colorado

### **IDEA Concept and Product**

This is a contract to design, develop, and test a prototype system to detect cracks in rail wheels from the wayside using a laser/air hybrid ultrasonic technique (LAHUT). The LAHUT uses laser pulses to excite ultrasonic waves in the object to be tested, e.g., a wheel. Air-coupled capacitive transducers receive the ultrasonic signals subsequently emitted by the test object after the waves have traveled through the area of inspection. The innovative feature of this technique is that no direct contact with the test object (wheel) is required. This enables automated inspection of wheels as trains roll by a wayside inspection station. The system developed in this contract will be designed to detect shattered rim cracks. If successful, post-contract

developments could include detection of flange stress cracks and tread stress cracks. The investigative approach includes development of system requirements, the design and fabrication of the prototype system, and the test and evaluation of the prototype in the laboratory and in the field. Field testing will be conducted in TTCI's Precision Test Track using a dedicated test train with wheels containing selected wheel flaws previously characterized using conventional non-destructive testing techniques.

### **Project Progress**

The LAHUT-based wayside cracked wheel detection system prototype is currently in the system integration and development stage of the project. Initially, system requirements and the design concept were developed. After the initial design concept was finalized, lab work to determine the most reliable and efficient method of ultrasonic generation in the wheel was completed. This lab work included testing different configurations for steering the laser beam to the wheel as well as determining optimal air-coupled sensor configurations. A detailed design of the entire prototype system has been completed.



**Figure 2**

*Installation of wayside LAHUT system at TTCI*



The dynamic detection station (DDS) track used to carry the DDS inspection carriage alongside the wheel during inspection was purchased and has been tested during system development. The DDS carriage has also been constructed and mounted to the DDS track. The DDS carriage includes several subsystems itself. The mirror/lens assembly, used to steer the laser beam to the wheel, was designed and constructed based on the lab work completed earlier in the year. The mechanism for positioning the ultrasonic sensors below the wheel tread was also designed and tested. The control system, which is responsible for aligning the DDS carriage to the wheel for inspection, was designed, developed, and tested over the past few months to ensure that the DDS carriage will be centered on the wheel during data collection. Finally the digital signal processing hardware was purchased and the software was written and tested.

The test cycle of the DDS carriage including wheel tracking, laser triggering, and data collection has been tested using wheelsets manually rolled past the DDS. Preparation for the TTC wayside site, including installation of the flange-bearing track work, construction of a con-

crete pad for supporting the DDS, and installing all of the utilities necessary for prototype operation and testing have been completed. Remaining tasks include full field testing of the prototype and analysis of the test data to determine how well the prototype system complied with the specifications and requirements, and how successfully it identified the wheel flaws in the test train.

Principal Investigator: Richard Morgan

Project Panel:

Shant Kenderian, NASA Jet Propulsion  
Laboratory

Dan Stone, Hunter Holiday Consulting

Clay Norman, Burlington Northern Santa Fe

IDEA Contract: \$100,000

Cost Sharing: \$300,000

Project Total: \$400,000

Start: March 2004

Complete: April 2005



**THE NATIONAL ACADEMIES™**  
*Advisers to the Nation on Science, Engineering, and Medicine*

The nation turns to the National Academies—National Academy of Sciences, National Academy of Engineering, Institute of Medicine, and National Research Council—for independent, objective advice on issues that affect people's lives worldwide.

[www.national-academies.org](http://www.national-academies.org)